



TRUE Planetary™ Gearheads

MICRON



Linear Motion. Optimized.™

Thomson -
Linear Motion. Optimized.

Often the ideal design solution is not about finding the fastest, sturdiest, most accurate or even the least expensive option. Rather, the ideal solution is the optimal balance of performance, life and cost.

Thomson is best positioned to help you most quickly configure the optimal linear motion solution for your application.

- Thomson invented anti-friction linear bearing technology. We own the broadest standard product offering of mechanical motion technologies in the industry.
- Modified versions of standard product are routine. White sheet design solutions available across our entire portfolio.
- Choose Thomson and gain access to over 70 years of global application experience in diverse industries including packaging, factory automation, material handling, medical, clean energy, printing, automotive, machine tool, aerospace and defense.
- As part of Danaher Motion, we are financially strong and unique in our ability to bring together control, drive, motor, power transmission and precision linear motion technologies.

Thomson is the name you can trust for quality, innovation, on-time delivery, controlled costs, and reduced risk.

In addition to the information contained in this document, a wealth of product and application information is available online at www.thomsonlinear.com. Also online are downloadable 3D models, software tools, our distributor locator and global contact information for Thomson. For immediate assistance in North America contact us at 1-540-633-3549 or email us at Thomson@danahermotion.com.

Talk to us early in the design process to see how Thomson can help identify the optimal balance of performance, life and cost for your next application. And, call us or any of our 2000+ distribution partners around the world for fast delivery of replacement parts.

The Danaher Business System - Building sustainable competitive advantage into your business

The Danaher Business System (DBS) was established to increase the value we bring to customers. It is a mature and successful set of tools we use daily to continually improve manufacturing operations and product development processes. DBS is based on the principles of Kaizen which continuously and aggressively eliminate waste in every aspect of our business. DBS focuses the entire organization on achieving breakthrough results that create competitive advantages in quality, delivery and performance – advantages that are passed on to you. Through these advantages Thomson is able to provide you faster times to market as well as unsurpassed product selection, service, reliability and productivity.

Local Support Around the Globe

Application Centers Global Manufacturing Operations Global Design & Engineering Centers



Product Overview 4
 True Planetary Gearheads 6
 Helical Crowned True Planetary Gearheads 7
 PowerTRUE™ Right Angle Gearheads 8
 RediMount™ Motor Mounting System 9
 Gearhead Selection 10
 Micron MOTIONEERING® 11

AquaTRUE™ True Planetary Gearheads 13
 AquaTRUE™ Introduction 14
 AquaTRUE™ Dimensions 15
 AquaTRUE™ Specifications 16
 Radial and Axial Load Ratings 17

XTRUE™ True Planetary Gearheads 18
 XTRUE™ Introduction 19
 XTRUE™ Dimensions 20
 XTRUE™ Specifications 21
 Radial and Axial Load Ratings 23

NemaTRUE™ True Planetary Gearheads 24
 NemaTRUE™ Size 17 25
 NemaTRUE™ Size 23/60 26
 NemaTRUE™ Size 34/90 27
 NemaTRUE™ Size 42/115 28
 Radial and Axial Load Ratings 29

NemaTRUE 90™ Right Angle Gearheads 30
 NemaTRUE 90™ Size 23 31
 NemaTRUE 90™ Size 34 32
 NemaTRUE 90™ Size 42 33
 Radial and Axial Load Ratings 34

DuraTRUE™ True Planetary Gearheads 36
 DuraTRUE™ Size 60 37
 DuraTRUE™ Size 90 38
 DuraTRUE™ Size 115 39
 DuraTRUE™ Size 142 40
 Radial and Axial Load Ratings 41

DuraTRUE 90™ Right Angle Gearheads 42
 DuraTRUE 90™ Size 60 43
 DuraTRUE 90™ Size 60S (Slim Line) 44
 DuraTRUE 90™ Size 90 45
 DuraTRUE 90™ Size 90S (Slim Line) 46
 DuraTRUE 90™ Size 115 47
 DuraTRUE 90™ Size 115S (Slim Line) 48
 DuraTRUE 90™ Size 142 49
 DuraTRUE 90™ Size 142S (Slim Line) 50
 Radial and Axial Load Ratings 51

DuraTRUE 90™ (Hollow Shaft) Right Angle Gearheads 54
 DuraTRUE 90™ Size 90H 55
 DuraTRUE 90™ Size 115H 56
 DuraTRUE 90™ Size 142H 57
 Radial and Axial Load Ratings 58

DuraTRUE 90™ (Dual Shaft) Right Angle Gearheads ... 60
 DuraTRUE 90™ Size 60D 61
 DuraTRUE 90™ Size 90D 62
 DuraTRUE 90™ Size 115D 63
 DuraTRUE 90™ Size 142D 64
 Radial and Axial Load Ratings 65

ValueTRUE™ True Planetary Gearheads 67
 ValueTRUE Inline Dimensions 68
 ValueTRUE Right Angle Dimensions 69
 Inline Specifications: VT006-VT010 70
 Inline Specifications: VT115-VT022 71
 Right Angle Specifications: VTR006-VTR075 72
 Right Angle Specifications: VTR090-VTR010 73
 Right Angle Specifications: VTR115-VTR018 74
 Radial and Axial Load Ratings 75

UltraTRUE™ Helical True Planetary Gearheads 78
 UltraTRUE™ Size 60 79
 UltraTRUE™ Size 75 80
 UltraTRUE™ Size 90 81
 UltraTRUE™ Size 10 82
 UltraTRUE™ Size 115 83
 UltraTRUE™ Size 14 84
 UltraTRUE™ Size 18 85
 UltraTRUE™ Size 22 86
 Radial and Axial Load Ratings 87

UltraTRUE 90™ Helical Right Angle Gearheads 90
 UltraTRUE 90™ Size 60 91
 UltraTRUE 90™ Size 75 92
 UltraTRUE 90™ Size 90 93
 UltraTRUE 90™ Size 10 94
 UltraTRUE 90™ Size 115 95
 UltraTRUE 90™ Size 14 96
 UltraTRUE 90™ Size 18 97
 Radial and Axial Load Ratings 98

EverTRUE™ True Planetary Gearheads 100
 EverTRUE™ Size 10 101
 EverTRUE™ Size 14 102
 EverTRUE™ Size 18 103
 Radial and Axial Load Ratings 104

Gearhead Application Analysis Form 106
 Gearhead Ordering Information 107

Micron True Planetary™ Gearheads shipped within 24 hours!



Need it fast? Go to the back cover of the catalog for details.

AquaTRUE™

Features

- Precision: 13 arc-minutes
- Frame Sizes: 60mm, 80mm, 120mm and 160mm
- Torque Capacity: up to 876 Nm

- Ratio Availability: 3:1 thru 10:1
- Radial Load Capacity: up to 3730 N



XTRUE™

Features

- Precision: 13 arc-minutes
- Frame Sizes: 40mm, 60mm, 80mm, 120mm and 160mm
- Torque Capacity: up to 876 Nm

- Ratio Availability: 3:1 thru 100:1
- Radial Load Capacity: up to 3730 N



NemaTRUE™

Features

- Precision: 13 arc-minutes
- Frame Sizes: 60mm, 90mm and 115mm
- Torque Capacity: up to 180 Nm

- Ratio Availability: 3:1 thru 100:1
- Radial Load Capacity: up to 3730 N



**NemaTRUE 90™
Right Angle**

Features

- Precision: 13 arc-minutes
- Frame Sizes: 23mm, 34mm and 42mm
- Torque Capacity: up to 255 Nm

- Ratio Availability: 1:1 thru 500:1
- Radial Load Capacity: up to 2900 N



DuraTRUE™

Features

- Precision: 8 arc-minutes
- Frame Sizes: 60mm, 90mm, 115mm and 142mm
- Torque Capacity: up to 834 Nm

- Ratio Availability: 3:1 thru 100:1
- Radial Load Capacity: up to 11150 N



**DuraTRUE 90™
Right Angle**

Features

- Precision: 8 arc-minutes
- Frame Sizes: 60mm, 90mm, 115mm and 142mm
- Torque Capacity: up to 842 Nm

- Ratio Availability: 1:1 thru 500:1
- Radial Load Capacity: up to 11150 N



**DuraTRUE 90™
Hollow Shaft**

Features

- Precision: 8 arc-minutes
- Frame Sizes: 90mm, 115mm and 142mm
- Torque Capacity: up to 865 Nm

- Ratio Availability: 1:1 thru 500:1
- Radial Load Capacity: up to 11150 N



DuraTRUE 90™ Dual Shaft

Features

- Precision: 8 arc-minutes
- Frame Sizes: 60mm, 90mm, 115mm and 142mm
- Torque Capacity: up to 865 Nm
- Ratio Availability: 1:1 thru 500:1
- Radial Load Capacity: up to 11150 N



ValueTRUE™

Features

- Precision: 4 arc-minutes
- Frame Sizes: 60, 75, 90, 100, 115, 140, 180 and 220mm
- Torque Capacity: up to 2969 Nm
- Ratio Availability: 4:1 thru 100:1
- Radial Load Capacity: up to 37910 N



ValueTRUE 90™ Right Angle

Features

- Precision: 4 arc-minutes
- Frame Sizes: 60, 75, 90, 100, 115, 140 and 180mm
- Torque Capacity: up to 2800 Nm
- Ratio Availability: 1:1 thru 50:1
- Radial Load Capacity: up to 37910 N



UltraTRUE™

Features

- Precision: 4 arc-minutes
- Frame Sizes: 60mm, 75mm, 90mm, 100mm, 115mm, 140mm, 180mm and 220mm
- Torque Capacity: up to 3300 Nm
- Ratio Availability: 4:1 thru 100:1
- Radial Load Capacity: up to 37910 N



UltraTRUE 90™ Right Angle

Features

- Precision: 4 arc-minutes
- Frame Sizes: 60mm, 75mm, 90mm, 100mm, 115mm, 140mm and 180mm
- Torque Capacity: up to 3111 Nm
- Ratio Availability: 1:1 thru 50:1
- Radial Load Capacity: up to 37910 N



EverTRUE™ Continuous Duty

Features

- Precision: 4 arc-minutes
- Frame Sizes: 100, 140 and 180mm
- Torque Capacity: up to 1010 Nm
- Ratio Availability: 4:1 thru 100:1
- Radial Load Capacity: up to 44600 N



True Planetary™ Gearheads offer...

- High Torque to Size Ratio - allows compact design
- Low Backlash - eliminates positioning errors due to lost motion
- Inertia Matching - keeps servo system stable and in control
- High Rigidity - optimizes system response
- Self Re-lubrication - eliminates costly maintenance and downtime
- High Radial Load Capacity - mount pulleys and pinions directly on the output shaft



UltraTRUE™ output cage assembly

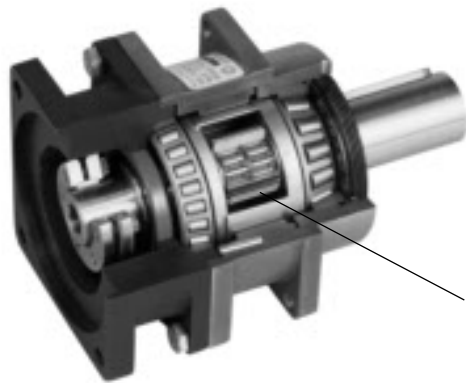

Planetary Gearing

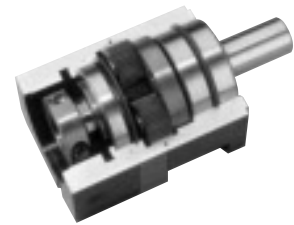

DuraTRUE™ in-line planetary gearhead

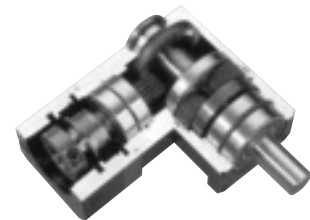

DuraTRUE 90™ right angle planetary gearhead

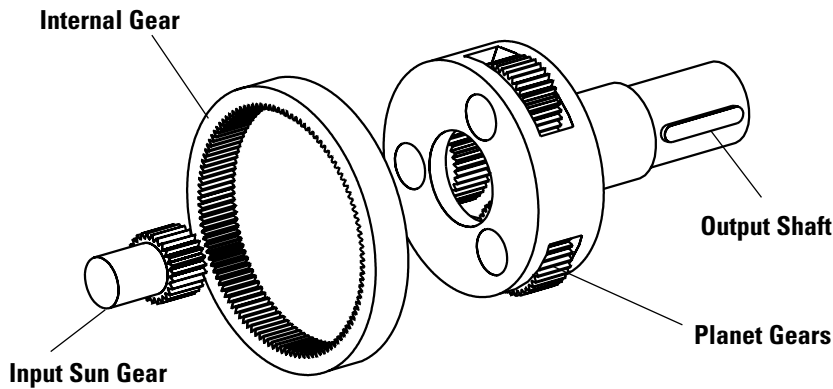

Gearhead	True Planetary gearing
AquaTRUE™	•
XTRUE™	•
NemaTRUE™	•
NemaTRUE 90™	•
DuraTRUE™	•
DuraTRUE 90™	•
UltraTRUE™	•
UltraTRUE 90™	•
ValueTRUE™	•
ValueTRUE 90™	•
EverTRUE™	

Helical Crowned True Planetary™ Gearing offers...

- High Torque Capacity
- Low Backlash
- Smooth Operation
- Greater Load Sharing
- Whisper Quiet

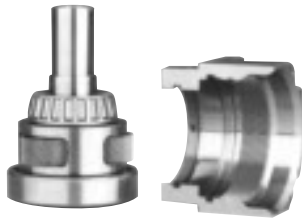

Output housing and helical internal gear are machined from a single piece of high strength steel

Helical gears are known for their quiet and smooth operation along with their ability to transmit higher loads than spur gears. Both of these features of helical gearing result from the improved contact ratio (effective teeth in mesh) over spur gears. Crowning is a modification to the gear tooth profile which optimizes gear mesh alignment. It also enhances distribution of loading on the tooth flank, thereby reducing high stress regions which can result in surface pitting.

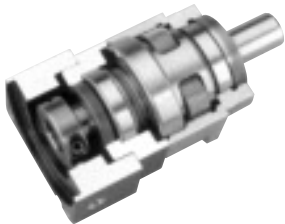

UltraTRUE™ in-line planetary gearhead

Planetary gearheads are often selected for high precision motion control applications which require a high torque to volume ratio, high torsional stiffness and low backlash. Until now, these attributes have been sufficient to meet the requirements of the market. Thomson has designed a high torque, whisper quiet helical gearhead to meet the recent improvements in servo motor technology.

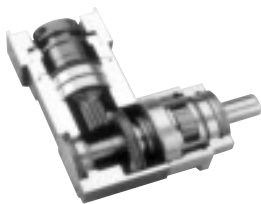

UltraTRUE 90™ right angle planetary gearhead

Thomson engineers accomplished this by combining the positive attributes of gear crowning and helical gearing with the planetary construction to create the smoothest operating gearhead on the market.

Spur vs. Helical Gearing

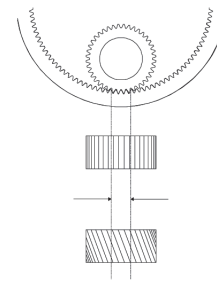

Typical contact ratio is 1.5 for spur gearing.

Contact ratio for equivalent helical gear is 3.3...more than double the contact ratio.

The Contact ratio is defined as the number of teeth in mesh at any given time. The higher the contact ratio, the higher the torque rating of the gearing. **Helical gearing has more than 2X the contact ratio of spur gearing.**

Crowned vs. Non-crowned

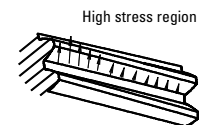

Non-Crowned

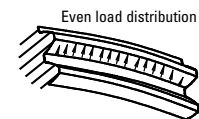

Crowned

Crowning optimizes the gear mesh alignment within a gear train to increase the torque capacity and reduce noise. It also enhances load distribution on the tooth flank to reduce high stress regions.

Gearhead	Helical Crowned True Planetary gearing
AquaTRUE™	
XTRUE™	
NemaTRUE™	
NemaTRUE 90™	
DuraTRUE™	
DuraTRUE 90™	
UltraTRUE™	•
UltraTRUE 90™	•
ValueTRUE™	•
ValueTRUE 90™	•
EverTRUE™	•

PowerTRUE™ Right Angle Gearheads offer...

- Lower backlash accomplished through single axis mesh adjustment
- A compact right angle design utilizing a high-tech face gear
- Whisper quiet operation due to high contact ratio
- Mesh ratios from 1:1 to 5:1
- 98% efficiency

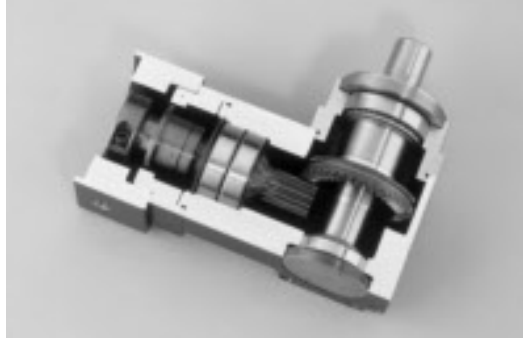

PowerTRUE™ Gear



Computerized mapping of gear tooth profile



CNC Machining of a PowerTRUE™ right angle gear

PowerTRUE™ right angle gearset



Right angle gear meshes are typically limited to ratios from 1:1 to 3:1 when using standard bevel gears. Compared to these designs, the PowerTRUE 90 gear increases the ratio range to 5:1.

The key to higher torque density is a unique tooth design, created by complex machining made practical with advanced CNC equipment and software. In the design, multiple teeth in the face gear simultaneously mesh with a standard involute pinion. The continuous tooth engagement yields a high contact ratio between the gear and the pinion, boosting torques to new levels and efficiency to 98%.

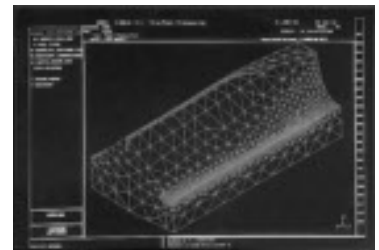

Advanced software enables stress analysis of PowerTRUE tooth profile

Gearhead	PowerTRUE gearing
AquaTRUE™	
XTRUE™	
NemaTRUE™	
NemaTRUE 90™	•
DuraTRUE™	
DuraTRUE 90™	•
UltraTRUE™	
UltraTRUE 90™	•
ValueTRUE™	
ValueTRUE 90™	•
EverTRUE™	

RediMount™ Motor Mounting System

Mounting Instructions

1. Slide the provided sleeve into the hub and align the slot in the bushing with the slot in the hub.
2. Set the motor on a work surface or hold fixture with the output shaft facing straight up. If there is a key on the motor, remove it and align the keyway with the slot in the hub. Slide the gearhead down onto the motor shaft.
3. Rotate the hub to align the input housing access holes with the hub clamping bolts.
4. Using a torque wrench tighten the hub bolts to the pre-torque value indicated in the table.
5. Bolt the motor to the gearhead with the bolts provided.
6. Gradually tighten the hub bolts in three steps, increasing the torque each time until reaching the final tightening torque in the table.



Hub Bolt Tightening Torques

Gearhead Model	Gearhead Frame Size	Pre-Tightening Torque		Final Tightening Torque	
		in-lb	[Nm]	in-lb	[Nm]
XTRUE™	60	2	0.2	39	4.4
	80	4	0.4	76	8.5
	120	16	1.8	316	36.0
	160	32	3.6	636	72.0
NemaTRUE™ NemaTRUE 90™	23/60	2	0.2	39	4.4
	34/90	4	0.4	76	8.5
	42/115	16	1.8	316	36.0
DuraTRUE™ DuraTRUE 90™	60	2	0.2	39	4.4
	90	4	0.4	76	8.5
	115	16	1.8	316	36.0
	142	32	3.6	636	72.0
UltraTRUE™ UltraTRUE 90™ ValueTRUE™ ValueTRUE90™ EverTRUE™	60	2	0.2	39	4.4
	75/90	4	0.4	76	8.5
	100/115	16	1.8	316	36.0
	140	32	3.6	636	72.0
	180	55	6.3	1104	125.0

Gearhead must be mounted in vertical orientation.

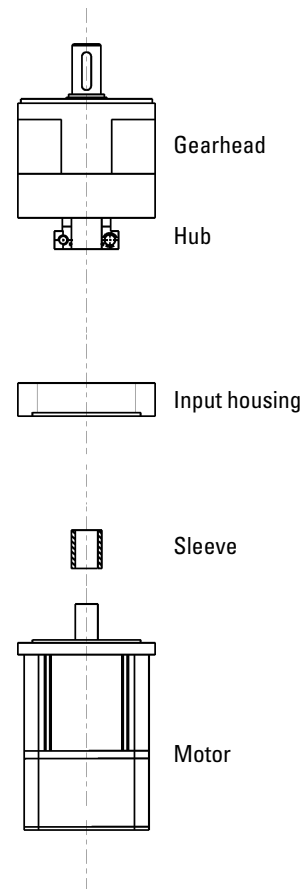

Selection

Step 1: Select the required precision class and gearhead configuration (in-line or right angle).

Step 2: Select the proper gearhead using exact or general method.

For continuous duty applications, please contact Applications Engineering.

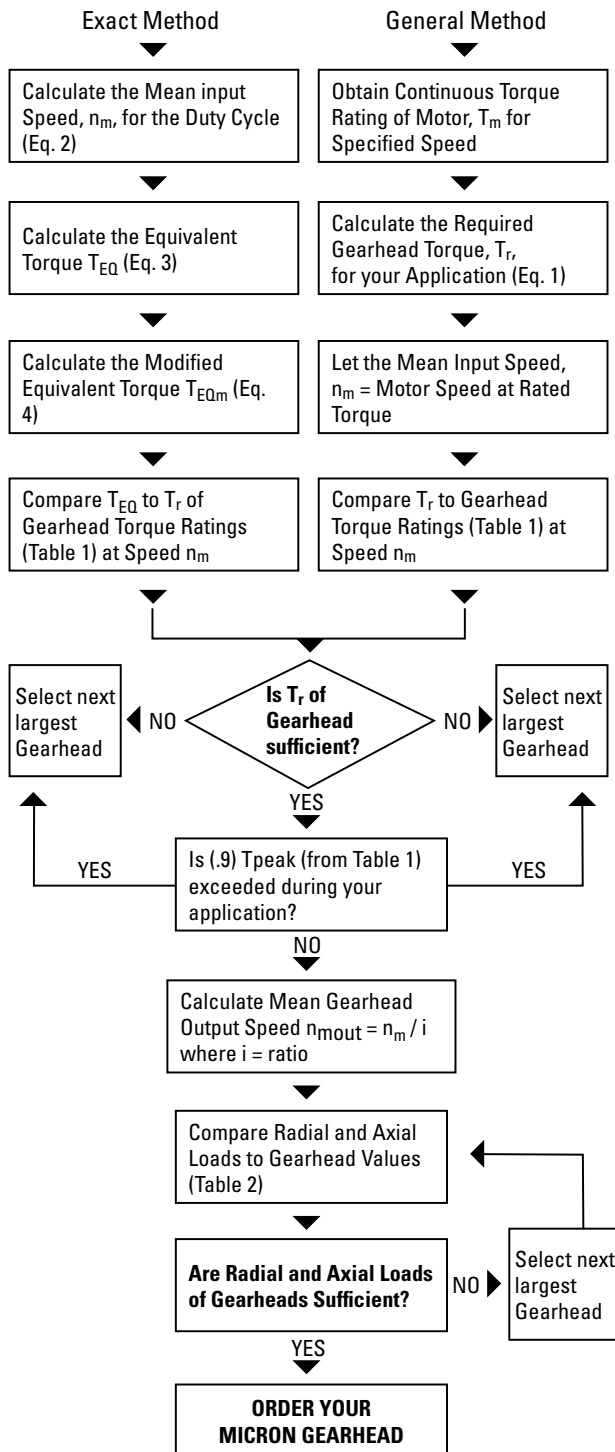

General Method:

Required Gearhead Torque(T_r)

$$(1) T_r = T_M * i * e$$

where: T_M^* = continuous torque of motor
 i = Gearhead ratio
 e = efficiency of Gearhead

* Since many motors are capable of exceeding their continuous torque rating for extended lengths of time, the value for T_M will only provide a starting point for Gearhead selection. Only use the general method if the continuous motor rating is not exceeded in the application.

Exact Method

Motion Profile

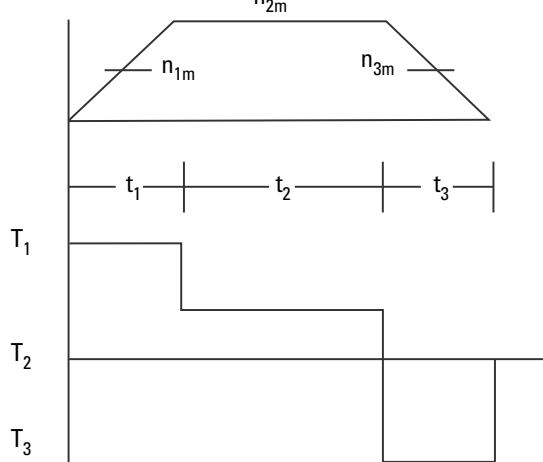

t_n = time period n

n_{nm} = mean speed during time period t_n

T_n = torque during time period t_n

Mean input speed (n_m)

$$(2) n_m = \frac{n_{1m}t_1 + n_{2m}t_2 + n_{3m}t_3 + \dots + n_{nm}t_n}{t_t}$$

where $t_t = t_1 + t_2 + t_3 + \dots + t_n$

Equivalent torque (T_{EQ})

$$(3) T_{EQ} = \sqrt[8.7]{T_1^{8.7} \frac{n_{1m}t_1}{n_m t_t} + T_2^{8.7} \frac{n_{2m}t_2}{n_m t_t} + T_3^{8.7} \frac{n_{3m}t_3 + \dots + T_n^{8.7} \frac{n_{nm}t_n}{n_m t_t}}$$

Modified equivalent torque (T_{EQm})

$$(4) T_{EQm} = (T_{EQ})/Q$$

Q	# of cycles/hr
1,0	>0
0,9	>1000
0,7	>2500
0,5	>5000

where Q is:

For applications > 10,000 cycles/hour or for continuous duty operation, please contact application engineering.

Micron MOTIONEERING®

The new web based sizing tool for Micron TRUE Planetary® Gearheads

Have Micron MOTIONEERING® do the application engineering work for you!

A new way to optimize your machine design, save time and, ultimately, help you build a better machine, faster. Easy to use and it's free at www.MicronMOTIONEERING.com

Micron MOTIONEERING has two different modes of functionality:

1. Sizing and Selection

Enter your application requirements in just a few easy steps to find the right gearhead for your application in the "Sizing and Selection" section.

2. Select Gearheads by Model Number

Search by product line, model number and ratio in the "Select Gearheads by Model Number" section. The tool quickly provides an orderable part number, pricing and delivery information.



Choose the selection mode that works best for you - "Select by Model Number" or "Sizing and Selection."

Select Gearheads by Model Number

If you know which gearhead you want, simply select the gearhead product line, frame size, ratio and RediMount*. Micron MOTIONEERING will provide the complete part number, pricing and delivery. Also available immediately are 3D models and a wealth of related catalog specifications.

- Don't know your RediMount? Choose from hundreds of the most popular motors on the market today or enter in your motor dimensions manually.
- Not sure if your motor fits on a specific gearhead? The tool will let you know if you have chosen a combination that is outside of the standard guidelines.



"Select Gearheads by Model Number" is quick and easy when you are familiar with Micron Gearheads and know what you're looking for.

Need a Gearhead in 24 hours? Use Gearhead Express!

The Micron MOTIONEERING tool lists all of the size and ratio combinations available to ship in 24 hours with the Gearhead Express Program.

*All Micron gearheads use the innovative RediMount™ system, the most flexible mounting system available today. This mounting system allows easy and error free mounting to any motor on the market in just three easy steps - simply align, mount and tighten.

Micron MOTIONEERING®

Web-based sizing and selection tool for Micron TRUE Planetary® Gearheads

Gearhead Sizing and Selection

Follow these easy steps for sizing and selection:

- Select orientation (in-line or right angle).
- Select backlash requirement.
- Select from all of the ratios available for that combination.
- If needed, you may account for radial and axial loads on the output shaft.
- Select a specific torque and speed requirement or build an entire motion profile.
- The tool will calculate your T_{eq} (equivalent torque) and display only solutions that will work in your application.
- If you do not know your RediMount, you can choose from a list of the most popular motors on the market today or enter your motor dimensions manually.
- Double check your configuration on the “Review Page.” Click any parameter to quickly edit if needed then submit to reveal a list available solutions, sorted by price.
- The torque safety factor will also be listed for each solution to help maximize the gearhead life.
- The final output delivers pricing, a printable summary of the design solution, and the ability to save it for future use.
- Also available are 3D models of your unique solution in neutral file formats or native CAD files for all major software packages (25+ formats available).

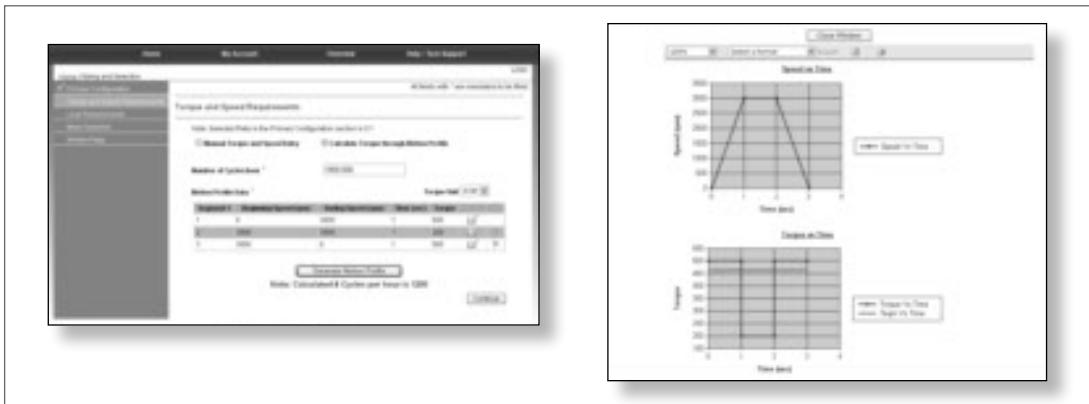

Use the Micron MOTIONEERING tool to help you build your motion profile.

Get started with Micron MOTIONEERING today!

- The Micron MOTIONEERING tool is very easy to use and is the fastest way to accurately size and select your next gearhead.
- Save money by seeing all the possible choices.
- Automatic calculations ensure the correct solution to fit your requirements.
- It does all of the work for you and gives you the correct solution to fit your requirements.



AquaTRUE™

True Planetary™ Gearheads

Ready for Immediate Delivery	
Precision	13 arc-minutes
Frame Sizes	60mm, 80mm, 120mm and 160mm
Torque Capacity	up to 876 Nm
Ratio Availability	3:1 thru 10:1
Radial load capacity	up to 3730 N
Mounting System	RediMount™

① Silicone Gasket to seal motor-gearhead interface

② Round and Square Motor Mounts

③ 1pc Housing - No External Seams

④ Permanent Product Label
(Laser Etched)

⑤ Tested for IP66, IP67 and IP69K Protection
Throughout

⑥ 300 Series Stainless Steel Housing

⑦ Non-Contact Labyrinth Seal for
Minimal wear and Maximum Protection

⑧ Stainless Steel Output Shaft

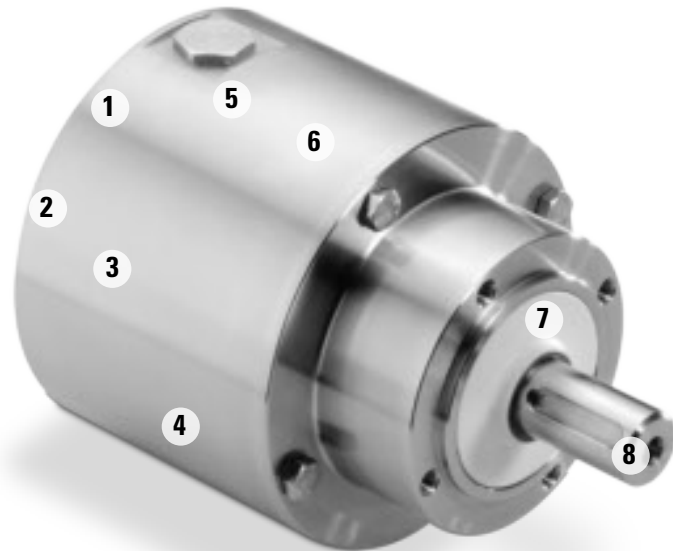

AquaTRUE™

A revolutionary, corrosion resistant and watertight gearhead for the most demanding applications.

Introduction

Micron's new AquaTRUE gearhead combines the high performance and torque capacity of Micron's True Planetary gearheads with features specifically designed to meet the strict requirements of applications such as food and beverage handling, packaging and dispensing. The AquaTRUE's IP66/IP67 and IP69K protection is able to handle caustic cleaning chemicals as well as high pressure washdown. Until now, manufacturers have been unable to use gearheads in many applications involving harsh environments because there was not a product available that met those needs. The AquaTRUE is engineered to be placed anywhere in the application's design, regardless of environmental factors. This eliminates the cost of additional components such as enclosers, shielding or mechanical transmissions.

The gearhead's 304 stainless steel housing eliminates the concern for rust or any type of corrosion. The AquaTRUE has a laser etched permanent product label and a smooth, round external housing that is designed without any external seams or corners for bacteria to collect. This makes the AquaTRUE very easy to clean and a perfect fit in any washdown environment.

- Frame Sizes: 60mm, 80mm, 120mm, 160mm
- Precision: 13 arc-min max
- Torque Capacity: up to 876 Nm
- Ratio Availability: 3:1 to 10:1 (single stage)

Features and Benefits

- Round Housing
- No External Seams
- 300 Series Stainless Steel
- IP66/IP67 and IP69K Protection on both the input and output
- NSF/ANSI 169 Certification
- No corners or areas for bacteria to collect
- No areas of ingress
- Corrosion Resistance
- Can handle high pressure washdown



AquaTRUE™

True Planetary™ Gearheads

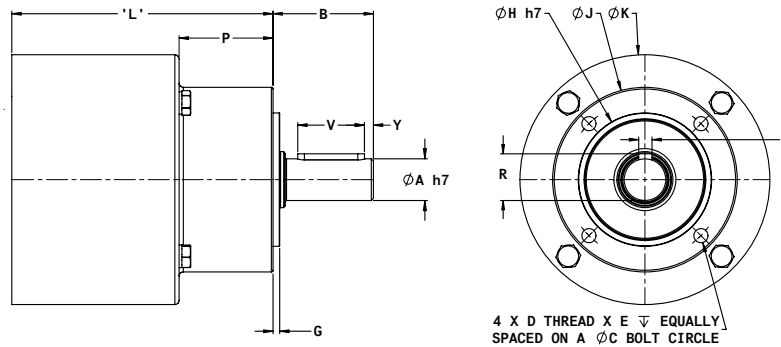

* 'L' Dimension will change depending on motor being used.
 Note: Mounting adapters available for both round and square motors.

Dimensions

Part Number	A Output Shaft Diameter mm [in]	B Output Shaft Length mm [in]	Y Shaft End Distance mm [in]	V Keyway Length mm [in]	R Keyway Height mm [in]	I Key Width mm [in]	H Pilot Diameter mm [in]	J Body Diameter mm [in]
AQT060	14 [0.55]	38 [1.51]	2.5 [0.10]	25 [0.98]	16 [0.63]	5 [0.20]	43 [1.69]	60 [2.36]
AQT080	20 [0.79]	42.4 [1.67]	4.0 [0.16]	28 [1.10]	22.5 [0.89]	6 [0.24]	60 [2.36]	80 [3.15]
AQT120	25 [0.98]	59.5 [2.34]	5 [0.20]	40 [1.57]	28 [1.10]	8 [0.31]	80 [3.15]	110.5 [4.36]
AQT160	40 [1.57]	90.5 [3.57]	8.0 [0.32]	65 [2.55]	43 [1.69]	12 [0.47]	105 [4.13]	140 [5.50]

Dimensions

Part Number	G Pilot Length mm [in]	D Output Housing Thread	Q Thread Depth mm [in]	K Input Body Diameter mm [in]	* L Standard Length mm [in]	C Bolt Circle mm [in]	P Output Body Length mm [in]
AQT060	6.9 [0.27]	M5x0.8-6H	12 [0.47]	92 [3.62]	91.6 [3.61]	52 [2.05]	38.5 [1.51]
AQT080	6.3 [0.25]	M6x1.0-6H	16 [0.63]	114.5 [4.51]	125.7 [4.95]	70 [2.76]	31.8 [1.25]
AQT120	7.3 [0.29]	M10x1.5-6H	22 [0.87]	150 [5.9]	149 [5.87]	95 [3.74]	56.9 [2.24]
AQT160	8.3 [0.33]	M12x1.75-6H	36 [1.42]	188.7 [7.43]	196.6 [7.74]	122.4 [4.82]	76.6 [3.02]

Specifications

Part Number	Stages	Backlash (arc-min)	Efficiency	Weight		Ratio Availability
				kg	[lbs]	
AQT060	1	13	93%	2.4	5.4	3:1, 4:1, 5:1, 7:1, 10:1
AQT080	1	13	93%	5.7	12.7	3:1, 4:1, 5:1, 7:1, 8:1, 10:1
AQT120	1	13	93%	12.0	26.5	3:1, 4:1, 5:1, 7:1, 10:1
AQT160	1	13	93%	24.8	53.8	3:1, 4:1, 5:1, 7:1, 10:1

T_r = Rated output torque at rated speed for specific hours of life.
 T_{peak} = Allowable momentary peak torque for emergency stop or heavy shock loading.
 J = Mass moment of inertia reflected to the input shaft (including pinion assembly).
 Specifications subject to change without notice.

AquaTRUE™

True Planetary™ Gearheads

Performance Specifications

Part Number	Ratio	20,000 Hour Life				T Peak Nm [in-lb]	J kg-cm2 [in-lb sec2*10-4]	Torsional Stiffness Nm/arc-min [in-lb/ arc-min]	
		Tr (1000 rpm) Nm [in-lb]	Tr (2000 rpm) Nm [in-lb]	Tr (3000 rpm) Nm [in-lb]	Tr (4000 rpm) Nm [in-lb]				
AQT060	AQT060-003	3:1	16 [139]	13 [112]	12 [102]	11 [93]	55 [483]	0.57 [5.1]	1.4 [12.6]
	AQT060-004	4:1	20 [177]	17 [149]	15 [130]	14 [121]	46 [409]	0.48 [4.0]	1.4 [12.1]
	AQT060-005	5:1	18 [158]	15 [130]	13 [112]	12 [102]	48 [427]	0.41 [3.6]	1.3 [11.8]
	AQT060-007	7:1	17 [149]	14 [121]	12 [102]	11 [93]	43 [381]	0.37 [3.2]	1.2 [11.0]
	AQT060-010	10:1	16 [139]	15 [130]	14 [121]	13 [112]	47 [418]	0.35 [3.1]	1.1 [10.1]
AQT080	AQT080-003	3:1	59 [520]	48 [427]	43 [381]	39 [344]	165 [1459]	2.4 [21.5]	5.8 [51.7]
	AQT080-004	4:1	70 [623]	58 [511]	53 [465]	48 [427]	165 [1459]	1.9 [17.1]	5.7 [50.5]
	AQT080-005	5:1	65 [576]	53 [465]	47 [418]	43 [381]	165 [1459]	1.7 [14.9]	5.5 [49.1]
	AQT080-007	7:1	63 [558]	50 [446]	45 [400]	40 [353]	165 [1459]	1.5 [13.0]	4.9 [43.0]
	AQT080-008	8:1	62 [549]	49 [434]	45 [398]	42 [372]	165 [1460]	1.4 [12.6]	4.6 [41.0]
	AQT080-010	10:1	54 [474]	48 [427]	45 [400]	43 [381]	165 [1459]	1.4 [12.3]	4.9 [43.2]
AQT120	AQT120-003	3:1	90 [799]	74 [650]	65 [576]	59 [520]	298 [2639]	9.0 [80]	12.1 [107]
	AQT120-004	4:1	107 [948]	89 [790]	79 [697]	74 [650]	298 [2639]	7.3 [65]	11.7 [103]
	AQT120-005	5:1	99 [873]	81 [716]	71 [632]	65 [576]	298 [2639]	6.5 [57]	11.3 [100]
	AQT120-007	7:1	97 [855]	79 [697]	68 [604]	63 [558]	298 [2639]	5.7 [51]	10.6 [94]
	AQT120-010	10:1	87 [771]	79 [697]	74 [650]	69 [613]	298 [2639]	5.4 [48]	9.8 [87]
AQT160	AQT160-003	3:1	317 [2806]	257 [2277]	228 [2016]	209 [1849]	876 [7750]	37 [327]	42.4 [375]
	AQT160-004	4:1	371 [3280]	305 [2695]	272 [2407]	251 [2221]	876 [7750]	27 [239]	39.7 [351]
	AQT160-005	5:1	350 [3094]	284 [2509]	251 [2221]	230 [2035]	876 [7750]	22 [195]	37.6 [333]
	AQT160-007	7:1	344 [3048]	278 [2463]	246 [2174]	225 [1989]	876 [7750]	19 [168]	34.6 [306]
	AQT160-010	10:1	222 [1961]	198 [1756]	185 [1635]	175 [1552]	876 [7750]	17 [150]	31.2 [276]

Tr = Rated output torque at rated speed for specific hours of life.
T_{peak} = Allowable momentary peak torque for emergency stop or heavy shock loading.
J = Mass moment of inertia reflected to the input shaft (including pinion assembly).
Specifications subject to change without notice.

AquaTRUE™

True Planetary™ Gearheads

Radial and Axial Load Ratings

AQT060

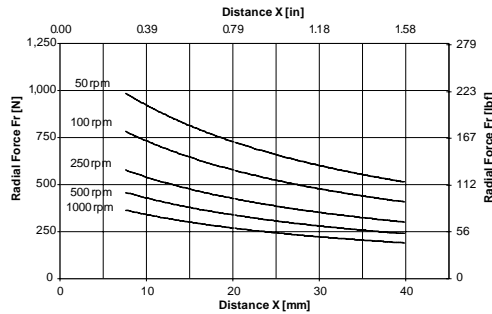
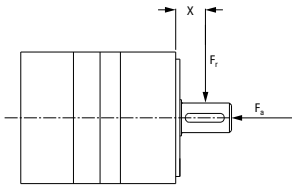

Speed rpm	Axial Load, F_a N [lb _f]
50	2542 [571]
100	2017 [454]
250	1486 [334]
500	1180 [265]
1000	936 [211]

AQT080

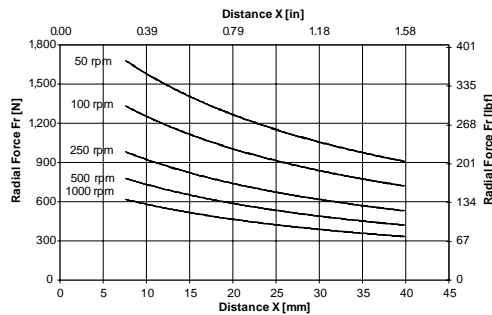
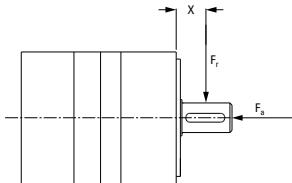

Speed rpm	Axial Load, F_a N [lb _f]
50	3780 [850]
100	3000 [675]
250	2211 [497]
500	1755 [394]
1000	1393 [313]

AQT120

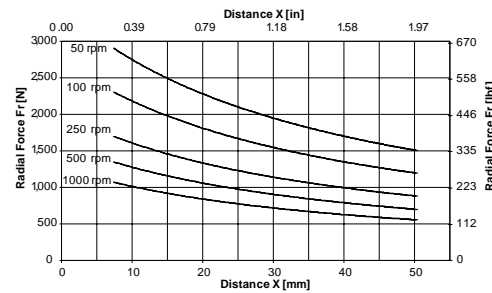
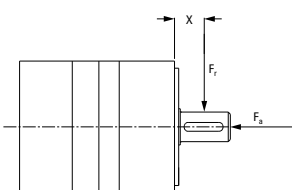

Speed rpm	Axial Load, F_a N [lb _f]
50	6894 [1550]
100	5471 [1230]
250	4034 [907]
500	3203 [720]
1000	2540 [571]

AQT160

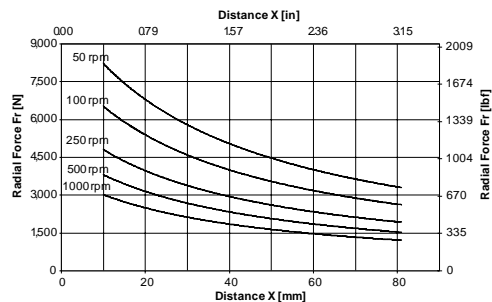
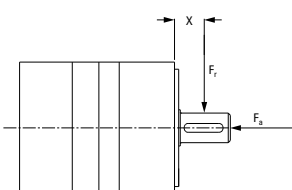

Speed rpm	Axial Load, F_a N [lb _f]
50	14,122 [3175]
100	11,209 [2520]
250	8260 [1857]
500	6556 [1474]
1000	5204 [1170]

These graphs display the allowable radial load at a given distance (X) from the mounting surface based on an L_{10} life of 20,000 hours for the mean output speed.



XTRUE™

True Planetary™ Gearheads

Ready for Immediate Delivery	
Precision	13 arc-minutes
Frame Sizes	40mm, 60mm, 80mm, 120mm and 160mm
Torque Capacity	up to 876 Nm
Ratio Availability	3:1 thru 100:1
Radial load capacity	up to 3730 N
Mounting System	RediMount™

- ① **Sealed deep groove ball bearings**
provide high radial load carrying capability
- ② **HRC 55-60 steel gears**
provide superior wear resistance
and increased backlash integrity
- ③ **Sealed deep groove ball bearing**
provides precision alignment of sun gear
- ④ **RediMount™ system**
provides error-free motor installation
- ⑤ **Anodized aluminum housing**
reduces weight and prevents corrosion

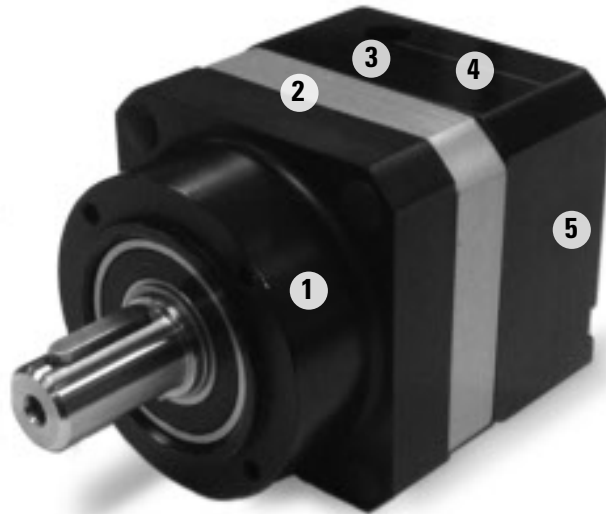

XTRUE™

True Planetary™ Gearheads

Introduction

The XTRUE Series is a new precision gearhead that complements our True Planetary™ Gearhead line, already the largest selection of planetary gearheads in the world.

Features and Benefits

- Frame sizes (5): 40mm, 60mm, 80mm, 120mm, 160mm
- Precision: 13 arc-mins
- Torque capacity: up to 876 Nm
- Ratio availability: 3:1 thru 100:1
- Move a larger load more easily and quietly with True planetary gearing through improved load capacity, lower backlash and quieter operation.
- Experience less downtime with the flexible mounting system: RediMount™ system mounts to any motor in 3 easy steps; align, mount and tighten.
- Simplify replacement with the tapped face output which enables easy drop-in replacement.
- Go green on your machine when the assembly and all components meet EU Directive 2002/95/EC (RoHS)

XTRUE™

True Planetary™ Gearheads

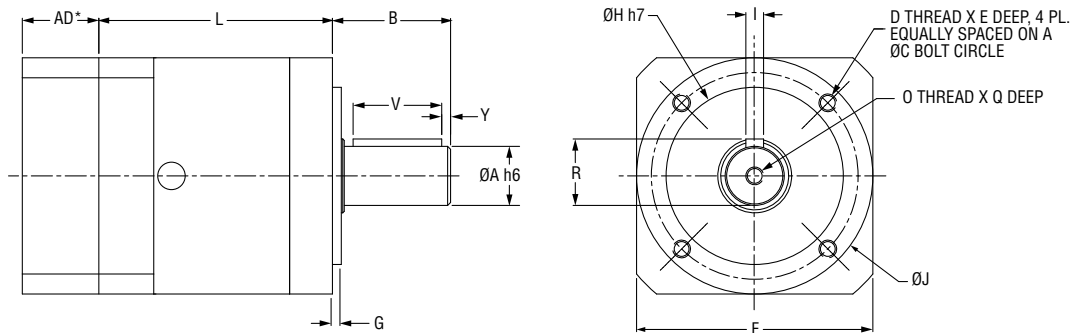

*AD = Adapter Length
 Adapter Length will vary depending on motor. Consult customer service for details.

Dimensions

Part Number	A Output Shaft Diameter mm [in]	B Output Shaft Length mm [in]	Y Shaft End Distance mm [in]	V Keyway Length mm [in]	R Keyway Height mm [in]	I Key Width mm [in]	H Pilot Diameter mm [in]	J Body Diameter mm [in]	G Pilot Length mm [in]
XT040	10 [0.39]	26 [1.02]	2.5 [0.10]	18 [0.71]	11.2 [0.44]	3 [0.12]	26 [1.02]	40 [1.57]	2 [0.08]
XT060	14 [0.55]	35 [1.37]	2.5 [0.10]	25 [0.98]	16 [0.63]	5 [0.20]	40 [1.57]	60 [2.36]	3 [0.12]
XT080	20 [0.79]	40 [1.57]	4.0 [0.16]	28 [1.10]	22.5 [0.89]	6 [0.24]	60 [2.36]	80 [3.15]	3 [0.12]
XT120	25 [0.98]	55 [2.16]	5.0 [0.20]	40 [1.57]	28 [1.10]	8 [0.31]	80 [3.15]	115 [4.53]	4 [0.16]
XT160	40 [1.57]	87 [3.42]	8.0 [0.32]	65 [2.55]	43 [1.69]	12 [0.47]	130 [5.12]	160 [6.30]	5 [0.20]

Dimensions

Part Number	D Thread	E Thread Depth mm [in]	O Output Shaft Thread	Q Thread Depth mm [in]	F Flange Square mm [in]	L Length mm [in]		C Bolt Circle mm [in]
						3:1 - 10:1	15:1 - 100:1	
XT040	M4	6 [0.24]	M3	9 [0.35]	42 [1.65]	36.5 [1.43]	49.5 [1.94]	34 [1.34]
XT060	M5	8 [0.31]	M5	12 [0.47]	61 [2.40]	51 [2.00]	68 [2.67]	52 [2.05]
XT080	M6	10 [0.39]	M6	16 [0.63]	90 [3.54]	67 [2.64]	90 [3.54]	70 [2.76]
XT120	M10	16 [0.63]	M10	22 [0.87]	119 [4.53]	87.3 [3.44]	179 [4.67]	100 [3.94]
XT160	M12	20 [0.79]	M16	36 [1.42]	142 [5.59]	119.6 [4.71]	168.9 [6.65]	145 [5.71]

Specifications

Part Number	Stages	Backlash (arc-min)	Efficiency	Weight		Ratio Availability
				kg	[lbs]	
XT040	1	13	93%	0.45	[1.0]	3:1, 5:1, 10:1
	2	15	88%	0.5	[1.1]	15:1; 25:1, 30:1, 50:1, 100:1
XT060	1	13	93%	1.0	[2.2]	3:1, 4:1, 5:1, 7:1; 10:1
	2	15	88%	1.2	[2.6]	15:1, 20:1, 25:1, 30:1, 40:1, 50:1; 70:1; 100:1
XT080	1	13	93%	3.0	[6.6]	3:1, 4:1, 5:1, 7:1; 8:1; 10:1
	2	15	88%	3.7	[8.1]	15:1, 20:1, 25:1, 30:1, 40:1, 50:1; 70:1; 80:1; 100:1
XT120	1	13	93%	5.7	[12.5]	3:1, 4:1, 5:1, 7:1; 10:1
	2	15	88%	7.3	[16.1]	15:1, 20:1, 25:1, 30:1, 40:1, 50:1; 70:1; 100:1
XT160	1	13	93%	12.8	[28.2]	3:1, 4:1, 5:1, 7:1; 10:1
	2	15	88%	17.2	[37.8]	15:1, 20:1, 25:1, 30:1, 40:1, 50:1; 70:1; 100:1

Specifications subject to change without notice.

Performance Specifications

Part Number	Ratio	20000 Hour Life				T _{peak} Nm [in-lb]	J kg-cm ² [in-lb-sec ² *10 ⁻⁴]	Torsional Stiffness Nm/arc-min [in-lb/arc-min]	
		T _r (1000 rpm) Nm [in-lb]	T _r (2000 rpm) Nm [in-lb]	T _r (3000 rpm) Nm [in-lb]	T _r (4000 rpm) Nm [in-lb]				
XT040	XT040-003	3:1	5.2 [46]	4.2 [37]	3.7 [33]	3.4 [30]	15.6 [138]	0.013 [0.12]	0.7 [6.2]
	XT040-005	5:1	6.1 [54]	5.3 [47]	3.6 [32]	4.3 [38]	18.3 [162]	0.005 [0.04]	0.7 [6.2]
	XT040-010	10:1	5.8 [51]	4.6 [41]	4.1 [36]	3.7 [33]	17.2 [152]	0.003 [0.03]	0.7 [6.2]
	XT040-015	15:1	8.4 [74]	6.8 [60]	6.0 [53]	5.5 [49]	25.2 [223]	0.004 [0.04]	0.7 [6.2]
	XT040-025	25:1	9.3 [82]	7.6 [67]	6.7 [59]	6.1 [54]	27.8 [246]	0.004 [0.04]	0.7 [6.2]
	XT040-030	30:1	9.5 [84]	8.4 [74]	7.5 [66]	6.8 [60]	28.6 [253]	0.003 [0.03]	0.7 [6.2]
	XT040-050	50:1	11.3 [100]	9.3 [82]	8.2 [73]	7.6 [67]	33.8 [299]	0.003 [0.03]	0.7 [6.2]
	XT040-100	100:1	8.1 [72]	7.5 [66]	7.1 [63]	6.9 [61]	24.4 [216]	0.003 [0.03]	0.7 [6.2]
XT060	XT060-003	3:1	16 [139]	13 [112]	12 [102]	11 [93]	55 [483]	0.52 [4.6]	1.8 [15.9]
	XT060-004	4:1	20 [177]	17 [149]	15 [130]	14 [121]	46 [409]	0.46 [4.1]	1.8 [15.9]
	XT060-005	5:1	18 [158]	15 [130]	13 [112]	12 [102]	48 [427]	0.46 [4.1]	1.8 [15.9]
	XT060-007	7:1	17 [149]	14 [121]	12 [102]	11 [93]	43 [381]	0.46 [4.1]	1.8 [15.9]
	XT060-010	10:1	16 [139]	15 [130]	14 [121]	13 [112]	47 [418]	0.44 [3.9]	1.8 [15.9]
	XT060-015	15:1	26 [232]	21 [186]	19 [167]	17 [149]	55 [483]	0.46 [4.1]	1.8 [15.9]
	XT060-020	20:1	27 [242]	25 [223]	22 [195]	21 [186]	48 [427]	0.46 [4.1]	1.8 [15.9]
	XT060-025	25:1	25 [223]	23 [204]	20 [177]	19 [167]	55 [483]	0.46 [4.1]	1.8 [15.9]
	XT060-030	30:1	29 [260]	26 [232]	23 [204]	21 [186]	55 [483]	0.46 [4.1]	1.8 [15.9]
	XT060-040	40:1	28 [251]	27 [242]	27 [242]	25 [223]	48 [427]	0.44 [3.9]	1.8 [15.9]
	XT060-050	50:1	26 [232]	25 [223]	25 [223]	23 [204]	55 [483]	0.44 [3.9]	1.8 [15.9]
	XT060-070	70:1	25 [223]	24 [214]	24 [214]	22 [195]	48 [427]	0.44 [3.9]	1.8 [15.9]
	XT060-100	100:1	21 [186]	20 [177]	19 [167]	18 [158]	43 [381]	0.44 [3.9]	1.8 [15.9]
XT080	XT080-003	3:1	59 [520]	48 [427]	43 [381]	39 [344]	165 [1459]	2.2 [19.5]	5.4 [47.8]
	XT080-004	4:1	70 [623]	58 [511]	53 [465]	48 [427]	165 [1459]	1.8 [15.9]	5.4 [47.8]
	XT080-005	5:1	65 [576]	53 [465]	47 [418]	43 [381]	165 [1459]	1.8 [15.9]	5.4 [47.8]
	XT080-007	7:1	63 [558]	50 [446]	45 [400]	40 [353]	165 [1459]	1.7 [15.0]	5.4 [47.8]
	XT080-008	8:1	62 [549]	49 [434]	45 [398]	42 [372]	165 [1460]	1.6 [14.2]	5.4 [47.8]
	XT080-010	10:1	54 [474]	48 [427]	45 [400]	43 [381]	165 [1459]	1.8 [15.9]	5.4 [47.8]
	XT080-015	15:1	90 [799]	78 [688]	69 [613]	63 [558]	175 [1552]	1.8 [15.9]	5.4 [47.8]
	XT080-020	20:1	92 [818]	88 [781]	81 [716]	75 [660]	175 [1552]	1.5 [13.3]	5.4 [47.8]
	XT080-025	25:1	87 [771]	83 [734]	76 [669]	69 [613]	175 [1552]	1.7 [15.0]	5.4 [47.8]
	XT080-030	30:1	100 [883]	90 [799]	85 [753]	78 [688]	175 [1552]	1.7 [15.0]	5.4 [47.8]
	XT080-040	40:1	96 [846]	92 [818]	90 [799]	88 [781]	175 [1552]	1.6 [14.2]	5.4 [47.8]
	XT080-050	50:1	90 [799]	87 [771]	85 [753]	83 [734]	175 [1552]	1.6 [14.2]	5.4 [47.8]
	XT080-070	70:1	88 [781]	85 [753]	83 [734]	82 [725]	175 [1552]	1.6 [14.2]	5.4 [47.8]
	XT080-080	80:1	84 [743]	80 [708]	78 [690]	74 [655]	175 [1549]	1.6 [14.2]	5.4 [47.8]
XT080-100	100:1	72 [641]	67 [595]	63 [558]	61 [539]	175 [1552]	1.6 [14.2]	5.4 [47.8]	

T_r = Rated output torque at rated speed for specific hours of life.
 T_{peak} = Allowable momentary peak torque for emergency stop or heavy shock loading.
 J = Mass moment of inertia reflected to the input shaft (including pinion assembly).
 Specifications subject to change without notice.

XTRUE™

True Planetary™ Gearheads

Performance Specifications

Part Number	Ratio	20000 Hour Life				T _{peak} Nm [in-lb]	J kg-cm ² [in-lb-sec ² *10 ⁻⁴]	Torsional Stiffness Nm/arc-min [in-lb/arc-min]	
		T _r (1000 rpm) Nm [in-lb]	T _r (2000 rpm) Nm [in-lb]	T _r (3000 rpm) Nm [in-lb]	T _r (4000 rpm) Nm [in-lb]				
XT120	XT120-003	3:1	90 [799]	74 [650]	65 [576]	59 [520]	298 [2639]	4.4 [39]	17.4 [154.0]
	XT120-004	4:1	107 [948]	89 [790]	79 [697]	74 [650]	298 [2639]	3 [27]	17.4 [154.0]
	XT120-005	5:1	99 [873]	81 [716]	71 [632]	65 [576]	298 [2639]	2.9 [26]	17.4 [154.0]
	XT120-007	7:1	97 [855]	79 [697]	68 [604]	63 [558]	298 [2639]	2.8 [25]	17.4 [154.0]
	XT120-010	10:1	87 [771]	79 [697]	74 [650]	69 [613]	298 [2639]	2.5 [22]	17.4 [154.0]
	XT120-015	15:1	146 [1292]	119 [1050]	105 [929]	96 [846]	298 [2639]	2.9 [26]	17.4 [154.0]
	XT120-020	20:1	169 [1496]	139 [1227]	124 [1097]	114 [1013]	298 [2639]	2.9 [26]	17.4 [154.0]
	XT120-025	25:1	161 [1422]	130 [1152]	116 [1022]	106 [939]	298 [2639]	2.9 [26]	17.4 [154.0]
	XT120-030	30:1	180 [1589]	146 [1292]	129 [1143]	119 [1050]	298 [2639]	2.5 [22]	17.4 [154.0]
	XT120-040	40:1	187 [1654]	169 [1496]	150 [1329]	139 [1227]	298 [2639]	2.5 [22]	17.4 [154.0]
XT160	XT160-003	3:1	317 [2806]	257 [2277]	228 [2016]	209 [1849]	876 [7750]	23 [204]	50.5 [446.9]
	XT160-004	4:1	371 [3280]	305 [2695]	272 [2407]	251 [2221]	876 [7750]	15 [133]	50.5 [446.9]
	XT160-005	5:1	350 [3094]	284 [2509]	251 [2221]	230 [2035]	876 [7750]	14 [124]	50.5 [446.9]
	XT160-007	7:1	344 [3048]	278 [2463]	246 [2174]	225 [1989]	876 [7750]	15 [133]	50.5 [446.9]
	XT160-010	10:1	222 [1961]	198 [1756]	185 [1635]	175 [1552]	876 [7750]	12 [106]	50.5 [446.9]
	XT160-015	15:1	508 [4498]	417 [3689]	370 [3271]	339 [3001]	876 [7750]	15 [133]	50.5 [446.9]
	XT160-020	20:1	513 [4544]	481 [4256]	428 [3791]	395 [3494]	876 [7750]	15 [133]	50.5 [446.9]
	XT160-025	25:1	492 [4358]	460 [4070]	407 [3605]	374 [3308]	876 [7750]	15 [133]	50.5 [446.9]
	XT160-030	30:1	562 [4971]	508 [4498]	455 [4024]	417 [3689]	876 [7750]	12 [106]	50.5 [446.9]
	XT160-040	40:1	536 [4739]	513 [4544]	500 [4423]	481 [4256]	876 [7750]	13 [115]	50.5 [446.9]
XT160-050	50:1	515 [4553]	492 [4358]	479 [4237]	460 [4070]	876 [7750]	12 [106]	50.5 [446.9]	
XT160-070	70:1	509 [4507]	487 [4312]	474 [4191]	455 [4024]	876 [7750]	12 [106]	50.5 [446.9]	
XT160-100	100:1	306 [2704]	279 [2472]	265 [2342]	254 [2249]	876 [7750]	12 [106]	50.5 [446.9]	

T_r = Rated output torque at rated speed for specific hours of life.

T_{peak} = Allowable momentary peak torque for emergency stop or heavy shock loading.

J = Mass moment of inertia reflected to the input shaft (including pinion assembly).

Specifications subject to change without notice.

XTRUE™

True Planetary™ Gearheads

Radial and Axial Load Ratings

XT040

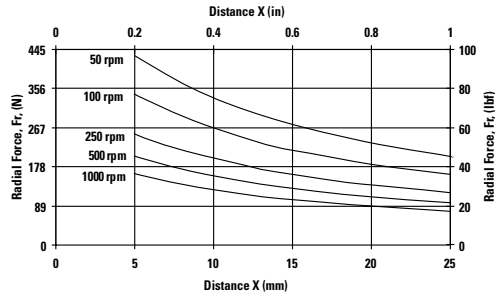
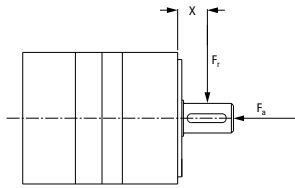

Speed rpm	Axial Load, F_a N [lb.]
50	737 [166]
100	585 [132]
250	431 [97]
500	342 [77]
1000	272 [61]

XT060

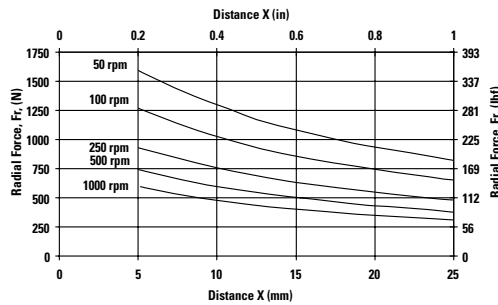
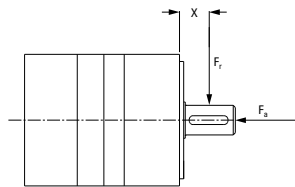

Speed rpm	Axial Load, F_a N [lb.]
50	2542 [571]
100	2017 [454]
250	1486 [334]
500	1180 [265]
1000	936 [211]

XT080

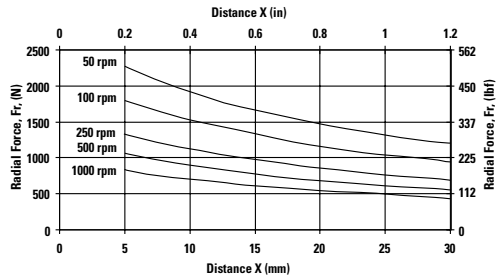
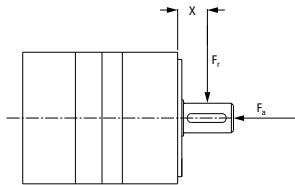

Speed rpm	Axial Load, F_a N [lb.]
50	3780 [850]
100	3000 [675]
250	2211 [497]
500	1755 [394]
1000	1393 [313]

XT120

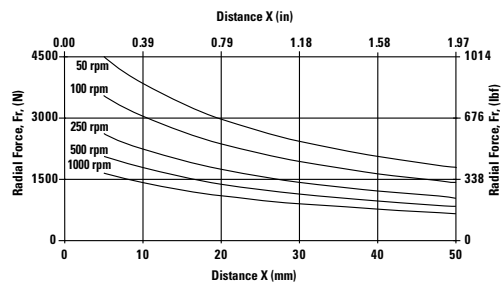
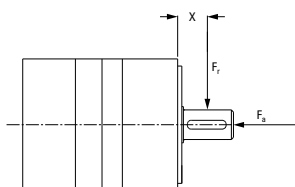

Speed rpm	Axial Load, F_a N [lb.]
50	6894 [1550]
100	5471 [1230]
250	4034 [907]
500	3203 [720]
1000	2540 [571]

XT160

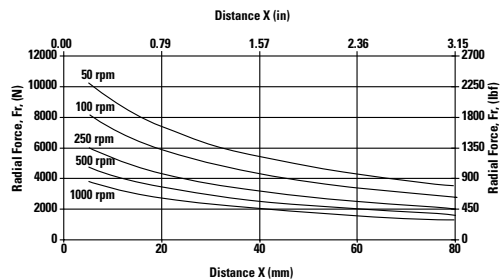
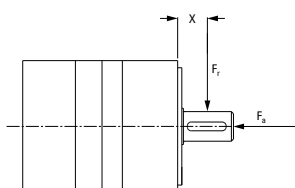

Speed rpm	Axial Load, F_a N [lb.]
50	14,122 [3175]
100	11,209 [2520]
250	8260 [1857]
500	6556 [1474]
1000	5204 [1170]

These graphs display the allowable radial load at a given distance (X) from the mounting surface based on an L_{10} life of 20,000 hours for the mean output speed.

NemaTRUE™

True Planetary™ Gearheads

Ready for Immediate Delivery	
Precision	13 arc-minutes
Frame Sizes	17, 23/60mm, 34/90mm and 42/115mm
Torque Capacity	up to 180 Nm
Ratio Availability	3:1 thru 100:1
Radial load capacity	up to 3730 N
Mounting System	RediMount™

- ① **Sealed deep groove ball bearings**
provide high radial load carrying capability
- ② **HRC 55-60 steel gears**
provide superior wear resistance
and increased backlash integrity
- ③ **Sealed deep groove ball bearing**
provides precision alignment of sun gear
- ④ **RediMount™ system**
provides error-free motor installation
- ⑤ **Anodized aluminum housing**
reduces weight and prevents corrosion

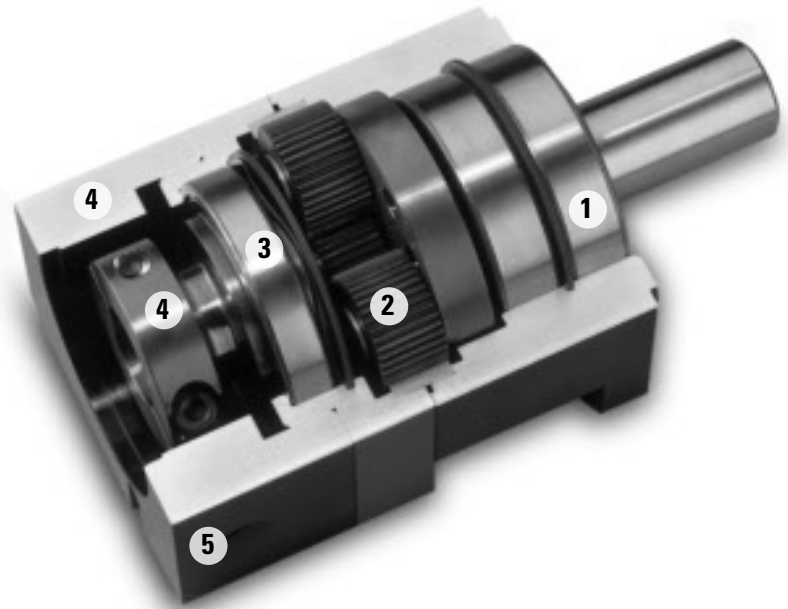

**Micron True Planetary™ Gearheads
shipped within 24 hours!**



**Need it fast? Go to the back cover
of the catalog for details.**

NemaTRUE™ Size 17

True Planetary™ Gearheads

English

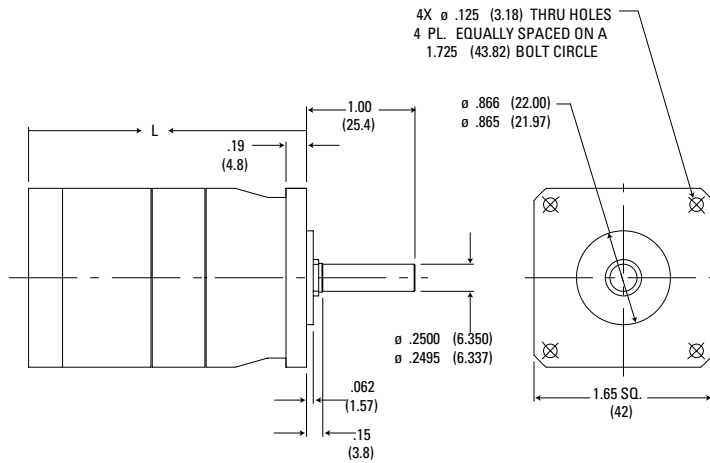

Ratio ¹	Dimension 'L' in [mm]	Backlash [arc-min]	Weight lb [kg]	Efficiency
3:1 to 10:1	2.28 [58]	13 max	.75 [0,34]	93%
15:1 to 100:1	2.77 [71]	15 max	.95 [0,43]	88%

Dimensions are inch (mm)
Efficiency is calculated at 100% of the rated torque.
Total length may change depending on motor being used.

Performance Specifications

Part Number	Ratio ¹	20000 Hour Life				T _{peak} in-lb [Nm]	J in-lb-sec ² ×10 ⁻⁴ [kg-cm ²]	Torsional Stiffness in-lb/arc-min [Nm/arc-min]
		T _r (1000 rpm) in-lb [Nm]	T _r (2000 rpm) in-lb [Nm]	T _r (3000 rpm) in-lb [Nm]	T _r (4000 rpm) in-lb [Nm]			
NT17-003	3:1	41 [4,7]	34 [3,8]	29 [3,3]	27 [3,1]	170 [19,2]	0.115 [0,013]	2.36 [0,268]
NT17-005	5:1	44 [5,0]	37 [4,2]	33 [3,7]	30 [3,4]	170 [19,2]	0.040 [0,005]	2.36 [0,268]
NT17-010	10:1	30 [3,4]	28 [3,1]	25 [2,8]	23 [2,6]	170 [19,2]	0.030 [0,003]	2.36 [0,268]
NT17-015	15:1	47 [5,3]	47 [5,3]	47 [5,3]	42 [4,7]	170 [19,2]	0.037 [0,004]	2.36 [0,268]
NT17-025	25:1	78 [8,8]	58 [6,6]	53 [6,0]	48 [5,5]	170 [19,2]	0.037 [0,004]	2.36 [0,268]
NT17-030	30:1	57 [6,4]	52 [5,9]	48 [5,4]	46 [5,2]	170 [19,2]	0.026 [0,003]	2.36 [0,268]
NT17-050	50:1	91 [10,3]	78 [8,8]	65 [7,4]	60 [6,7]	170 [19,2]	0.026 [0,003]	2.36 [0,268]
NT17-100	100:1	40 [4,5]	38 [4,3]	35 [4,0]	33 [3,8]	170 [19,2]	0.026 [0,003]	2.36 [0,268]

¹ Ratios are exact, higher ratios and other custom options are also available, consult factory.
T_r = Rated output torque at rated speed for specific hours of life.

T_{peak} = Allowable momentary peak torque for emergency stop or heavy shock loading.
J = Mass moment of inertia reflected to the input shaft (including pinion assembly).

NemaTRUE™ Size 23/60

English

English - Dimensions are in (mm)

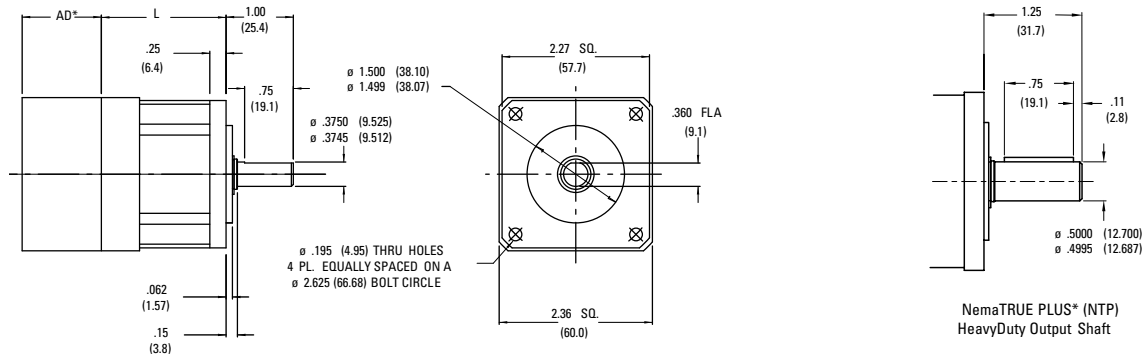

Metric - Dimensions are mm (in)

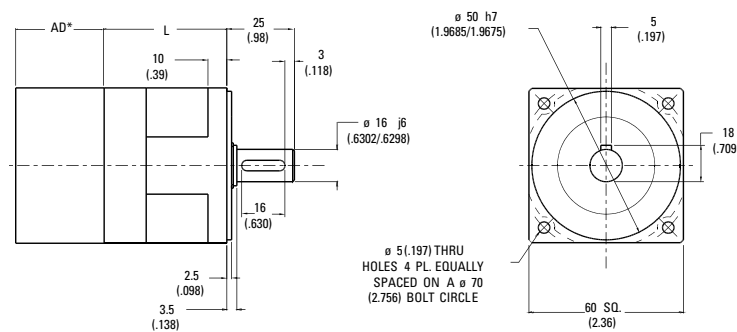

Ratio ¹	NT23	NT60	Backlash [arc-min]		Weight lb [kg]	Efficiency
	Dimension 'L' in [mm]	Dimension 'L' in [mm]	Precision	High Precision		
3:1 to 10:1	1.92 [48,8]	2.07 [52,6]	13 max	8 max	1.5 [0,7]	93%
15:1 to 100:1	2.61 [66,3]	2.76 [70,1]	15 max	9 max	1.9 [0,9]	88%

AD** = Adapter length
 Adapter length will vary depending on motor.
 Efficiency is calculated at 100% of the rated torque.

Performance Specifications

Part Number		Ratio ¹	20000 Hour Life				T _{peak} in-lb [Nm]	J in-lb-sec ² x10 ⁻⁴ [kg-cm ²]	Torsional Stiffness in-lb/arc-min [Nm/arc-min]	
English	Metric		T _r (1000 rpm) in-lb [Nm]	T _r (2000 rpm) in-lb [Nm]	T _r (3000 rpm) in-lb [Nm]	T _r (4000 rpm) in-lb [Nm]			NT	NTP
NT23-003	NT60-003		3:1	98 [11,1]	80 [9,0]	70 [7,9]			65 [7,3]	150 [16,9]
NT23-004	NT60-004	4:1	107 [12,1]	90 [10,2]	80 [9,0]	73 [8,2]	250 [28,3]	0.22 [0,024]	6.3 [0,71]	15.8 [1,8]
NT23-005	NT60-005	5:1	105 [11,9]	88 [9,9]	78 [8,8]	71 [8,0]	250 [28,2]	0.22 [0,025]	6.3 [0,71]	15.8 [1,8]
NT23-007	NT60-007	7:1	100 [11,3]	83 [9,4]	74 [8,4]	66 [7,5]	250 [28,3]	0.22 [0,024]	6.3 [0,71]	15.8 [1,8]
NT23-010	NT60-010	10:1	163 [7,1]	58 [6,6]	54 [6,1]	52 [5,9]	250 [28,2]	0.14 [0,016]	6.3 [0,71]	15.8 [1,8]
NT23-015	NT60-015	15:1	124 [14,0]	110 [12,4]	105 [11,9]	100 [11,3]	250 [28,3]	0.21 [0,024]	6.3 [0,71]	15.8 [1,8]
NT23-020	NT60-020	20:1	180 [20,3]	147 [16,6]	130 [14,7]	120 [13,6]	275 [31,1]	0.21 [0,024]	6.3 [0,71]	15.8 [1,8]
NT23-025	NT60-025	25:1	175 [9,8]	142 [16,0]	125 [14,1]	115 [13,0]	250 [28,3]	0.21 [0,024]	6.3 [0,71]	15.8 [1,8]
NT23-030	NT60-030	30:1	207 [23,4]	182 [20,6]	157 [17,7]	147 [16,6]	275 [31,1]	0.13 [0,015]	6.3 [0,71]	15.8 [1,8]
NT23-040	NT60-040	40:1	207 [23,4]	182 [20,6]	157 [17,7]	147 [16,6]	275 [31,1]	0.13 [0,015]	6.3 [0,71]	15.8 [1,8]
NT23-050	NT60-050	50:1	202 [22,8]	175 [19,8]	152 [17,2]	142 [16,0]	275 [31,1]	0.13 [0,015]	6.3 [0,71]	15.8 [1,8]
NT23-070	NT60-070	70:1	197 [22,3]	172 [19,4]	147 [16,6]	137 [15,5]	275 [31,1]	0.13 [0,015]	6.3 [0,71]	15.8 [1,8]
NT23-100	NT60-100	100:1	85 [9,6]	79 [8,9]	74 [8,9]	73 [8,2]	275 [31,1]	0.13 [0,015]	6.3 [0,71]	15.8 [1,8]

All ratios are available to ship in 24 hours through the Gearhead Express Program.

¹ Ratios are exact, higher ratios and other custom options are also available, consult factory.
 T_r = Rated output torque at rated speed for specific hours of life.

T_{peak} = Allowable momentary peak torque for emergency stop or heavy shock loading.
 J = Mass moment of inertia reflected to the input shaft (including pinion assembly).

NemaTRUE™ Size 34/90

True Planetary™ Gearheads

English

English - Dimensions are in (mm)

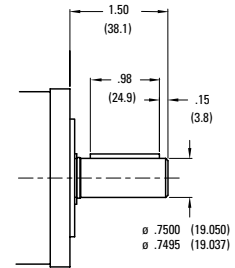
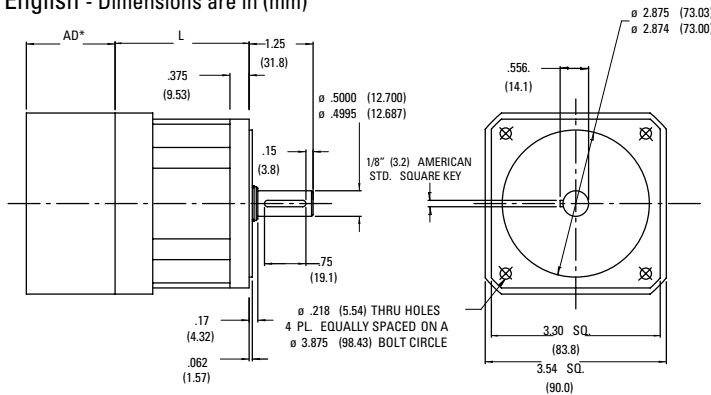

NemaTRUE PLUS* (NTP)
HeavyDuty Output Shaft

Metric - Dimensions are mm (in)

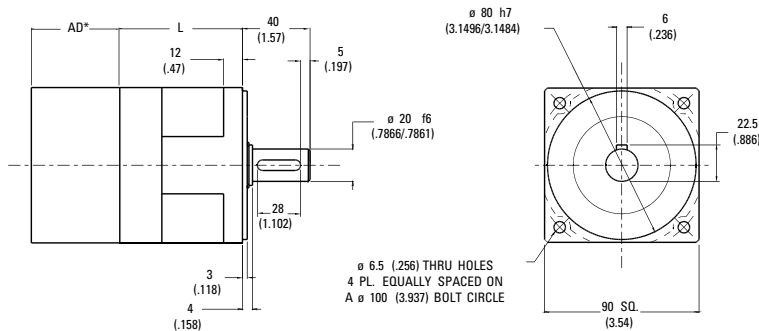

Ratio ¹	NT34 Dimension 'L' in [mm]	NT90 Dimension 'L' in [mm]	Backlash [arc-min]		Weight lb [kg]	Efficiency
			Precision	High Precision		
3:1 to 10:1	2.68 [68,0]	2.63 [66,8]	13 max	8 max	4.2 [1,9]	93%
15:1 to 100:1	3.53 [89,6]	3.53 [89,7]	15 max	9 max	5.6 [2,5]	88%

AD** = Adapter length
Adapter length will vary depending on motor.
Efficiency is calculated at 100% of the rated torque.

Performance Specifications

Part Number		Ratio ¹	20000 Hour Life				T _{peak} in-lb [Nm]	J in-lb-sec ² ×10 ⁻⁴ [kg-cm ²]	Torsional Stiffness in-lb/arc-min [Nm/arc-min]	
English	Metric		T _r (1000 rpm) in-lb [Nm]	T _r (2000 rpm) in-lb [Nm]	T _r (3000 rpm) in-lb [Nm]	T _r (4000 rpm) in-lb [Nm]			NT	NTP
NT34-003	NT90-003		3:1	360 [40,7]	320 [36,2]	295 [33,3]			270 [30,5]	510 [57,6]
NT34-004	NT90-004	4:1	515 [58,2]	425 [48,0]	380 [42,9]	350 [39,6]	700 [79,1]	1.20 [0,140]	16.8 [1,9]	48 [5,4]
NT34-005	NT90-005	5:1	490 [55,4]	400 [45,2]	355 [40,1]	325 [36,7]	700 [79,1]	1.20 [0,140]	16.8 [1,9]	48 [5,4]
NT34-007	NT90-007	7:1	470 [53,1]	380 [42,9]	335 [37,9]	305 [34,5]	700 [79,1]	1.20 [0,140]	16.8 [1,9]	48 [5,4]
NT34-010	NT90-010	10:1	238 [26,9]	212 [24,0]	200 [22,6]	192 [21,7]	700 [79,1]	0.66 [0,075]	16.8 [1,9]	48 [5,4]
NT34-015	NT90-015	15:1	454 [51,3]	416 [47,0]	391 [44,2]	373 [42,1]	850 [96,0]	1.20 [0,140]	16.8 [1,9]	48 [5,4]
NT34-020	NT90-020	20:1	677 [76,5]	620 [70,1]	587 [66,3]	551 [62,3]	850 [96,1]	1.20 [0,140]	16.8 [1,9]	48 [5,4]
NT34-025	NT90-025	25:1	652 [73,7]	595 [67,2]	562 [63,5]	526 [59,4]	850 [96,0]	1.20 [0,140]	16.8 [1,9]	48 [5,4]
NT34-030	NT90-030	30:1	500 [56,5]	454 [51,3]	432 [48,8]	416 [47,0]	850 [96,0]	0.66 [0,075]	16.8 [1,9]	48 [5,4]
NT34-040	NT90-040	40:1	770 [87,0]	702 [79,3]	668 [75,5]	620 [70,1]	850 [96,1]	0.65 [0,074]	16.8 [1,9]	48 [5,4]
NT34-050	NT90-050	50:1	720 [81,4]	652 [73,7]	618 [69,8]	595 [67,2]	850 [96,0]	0.65 [0,074]	16.8 [1,9]	48 [5,4]
NT34-070	NT90-070	70:1	770 [87,0]	702 [79,3]	668 [75,5]	620 [70,1]	850 [96,1]	0.65 [0,074]	16.8 [1,9]	48 [5,4]
NT34-100	NT90-100	100:1	325 [36,7]	295 [33,3]	280 [31,6]	270 [30,5]	700 [79,1]	0.65 [0,074]	16.8 [1,9]	48 [5,4]

All ratios are available to ship in 24 hours through the Gearhead Express Program.

¹ Ratios are exact, higher ratios and other custom options are also available, consult factory.
T_r = Rated output torque at rated speed for specific hours of life.

T_{peak} = Allowable momentary peak torque for emergency stop or heavy shock loading.
J = Mass moment of inertia reflected to the input shaft (including pinion assembly).

NemaTRUE™ Size 42/115

True Planetary™ Gearheads

English

English - Dimensions are in (mm)

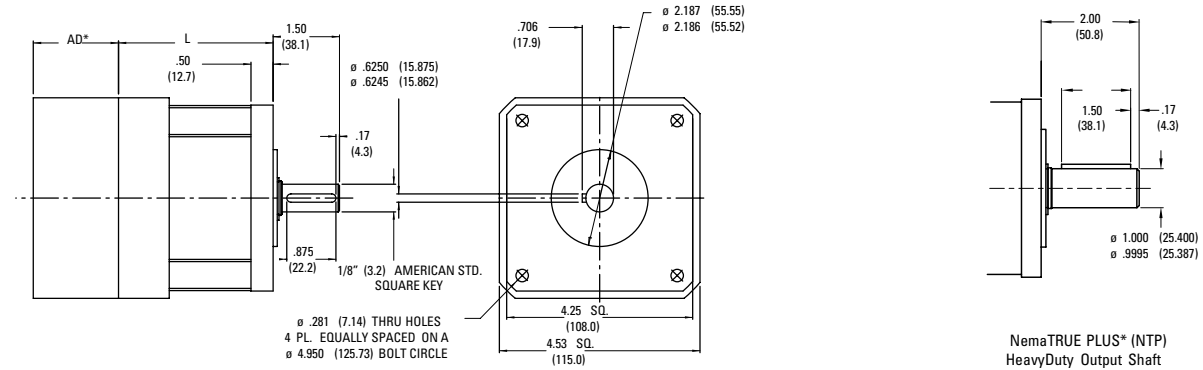

NemaTRUE PLUS* (NTP)
HeavyDuty Output Shaft

Metric - Dimensions are mm (in)

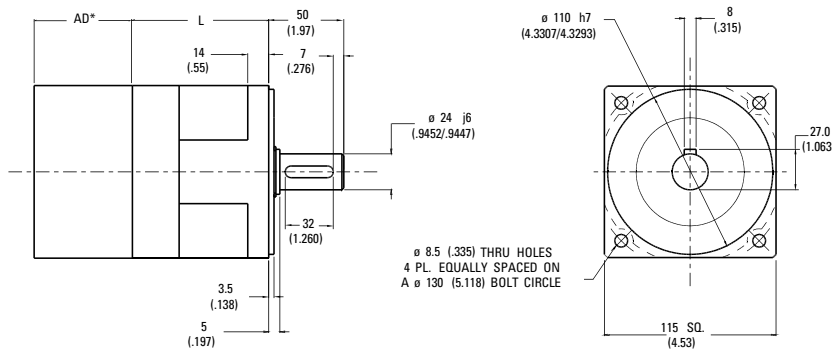

Ratio ¹	NT42	NT115	Backlash [arc-min]		Weight lb [kg]	Efficiency
	Dimension 'L' in [mm]	Dimension 'L' in [mm]	Precision	High Precision		
3:1 to 10:1	3.49 [88,6]	3.46 [87,9]	13 max	8 max	8.9 [4.0]	93%
15:1 to 100:1	4.72 [119,9]	4.69 [119,1]	15 max	9 max	11.7 [5.3]	88%

AD** = Adapter length
Adapter length will vary depending on motor.
Efficiency is calculated at 100% of the rated torque.

Performance Specifications

Part Number		Ratio ¹	20000 Hour Life				T _{peak} in-lb [Nm]	J in-lb-sec ² ×10 ⁻⁴ [kg-cm ²]	Torsional Stiffness in-lb/arc-min [Nm/arc-min]	
English	Metric		T _r (1000 rpm) in-lb [Nm]	T _r (2000 rpm) in-lb [Nm]	T _r (3000 rpm) in-lb [Nm]	T _r (4000 rpm) in-lb [Nm]			NT	NTP
NT42-003	NT115-003		3:1	690 [78.0]	594 [67.1]	530 [59.9]			485 [54.8]	1000 [113.0]
NT42-004	NT115-004	4:1	850 [96.1]	698 [78.9]	622 [70.3]	570 [64.4]	1000 [113.0]	3.80 [0.43]	31 [3.5]	154 [17.4]
NT42-005	NT115-005	5:1	810 [55.4]	400 [45.2]	355 [40.1]	325 [36.7]	1000 [113.0]	3.80 [0.43]	31 [3.5]	154 [17.4]
NT42-007	NT115-007	7:1	790 [89.3]	638 [72.1]	562 [63.5]	510 [57.6]	1000 [113.0]	3.80 [0.43]	31 [3.5]	154 [17.4]
NT42-010	NT115-010	10:1	460 [52.0]	412 [46.6]	388 [43.8]	370 [41.8]	1000 [113.0]	1.9 [0.21]	31 [3.5]	154 [17.4]
NT42-015	NT115-015	15:1	454 [51.3]	416 [47.0]	391 [44.2]	373 [42.1]	1600 [180.8]	3.9 [0.44]	31 [3.5]	154 [17.4]
NT42-020	NT115-020	20:1	1290 [145.8]	1090 [123.2]	985 [111.3]	905 [102.3]	1600 [180.8]	3.70 [0.42]	31 [3.5]	154 [17.4]
NT42-025	NT115-025	25:1	1250 [141.2]	1050 [118.6]	945 [106.8]	865 [97.7]	1600 [180.8]	3.70 [0.42]	31 [3.5]	154 [17.4]
NT42-030	NT115-030	30:1	972 [109.8]	878 [99.2]	842 [95.1]	805 [91.0]	1600 [180.8]	1.9 [0.21]	31 [3.5]	154 [17.4]
NT42-040	NT115-040	40:1	1435 [162.2]	1290 [145.8]	1190 [134.5]	1090 [123.2]	1600 [180.8]	1.80 [0.20]	31 [3.5]	154 [17.4]
NT42-050	NT115-050	50:1	1395 [157.6]	1250 [141.2]	1150 [118.6]	1050 [118.6]	1600 [180.8]	1.80 [0.20]	31 [3.5]	154 [17.4]
NT42-070	NT115-070	70:1	1375 [155.4]	1230 [139.0]	1130 [127.7]	1030 [116.4]	1600 [180.8]	1.80 [0.20]	31 [3.5]	154 [17.4]
NT42-100	NT115-100	100:1	630 [71.2]	575 [65.0]	540 [61.0]	522 [59.0]	1200 [135.6]	1.80 [0.20]	31 [3.5]	154 [17.4]

All ratios are available to ship in 24 hours through the Gearhead Express Program.

¹ Ratios are exact, higher ratios and other custom options are also available, consult factory.

T_r = Rated output torque at rated speed for specific hours of life.

T_{peak} = Allowable momentary peak torque for emergency stop or heavy shock loading.
J = Mass moment of inertia reflected to the input shaft (including pinion assembly).

Radial and Axial Load Ratings

NT17

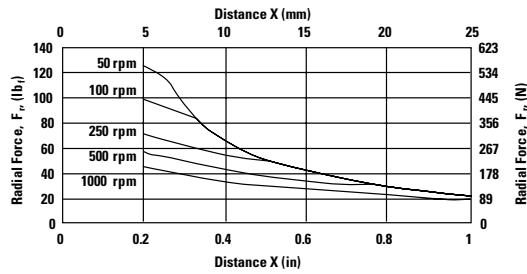
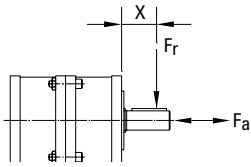

Speed rpm	Axial Load, F_a lb _f [N]
250	138 [614]

NT23, NTP23, NT60

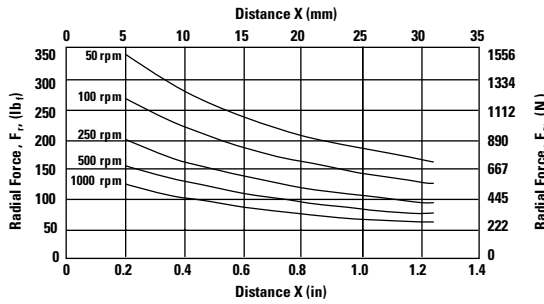
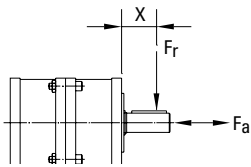

Speed rpm	Axial Load, F_a lb _f [N]
250	310 [1379]

NT34, NTP34, NT90

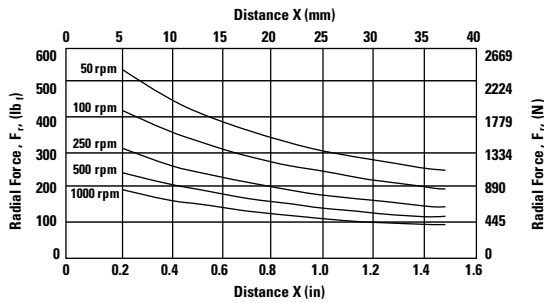
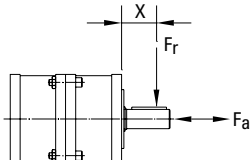

Speed rpm	Axial Load, F_a lb _f [N]
250	510 [2269]

NT42, NTP42, NT115

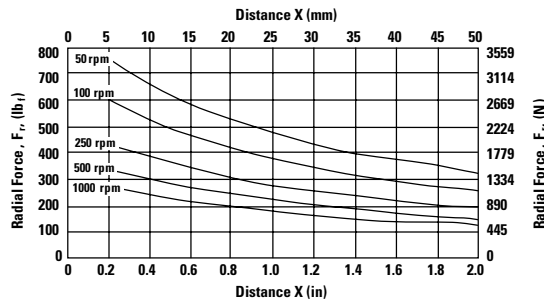
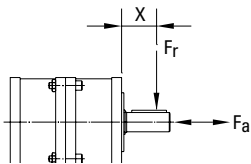

Speed rpm	Axial Load, F_a lb _f [N]
250	760 [3380]

These graphs display the allowable radial load at a given distance (X) from the mounting surface based on an L₁₀ life of 10,000 hours for the mean output speed n_{mout} , as described on page 10,

NemaTRUE™ 90

Right Angle Gearheads

Ready for Immediate Delivery	
Precision	13 arc-minutes
Frame Sizes	NEMA 23, 34, 42
Torque Capacity	up to 255 Nm
Ratio Availability	1:1 thru 500:1
Radial load capacity	up to 2900 N
Mounting System	RediMount™

- 1 Tapered Roller bearings**
provide high radial and axial load capacity
- 2 Innovative PowerTRUE* gearing**
delivers smooth, quiet geared reduction
- 3 Tapered roller bearings**
provide high axial load carrying capabilities
- 4 HRC 55-60 steel gears**
provide superior wear resistance and increased backlash integrity
- 5 RediMount system**
provides error-free motor installation



NemaTRUE™ 90 Size 23

Right Angle Gearheads

English

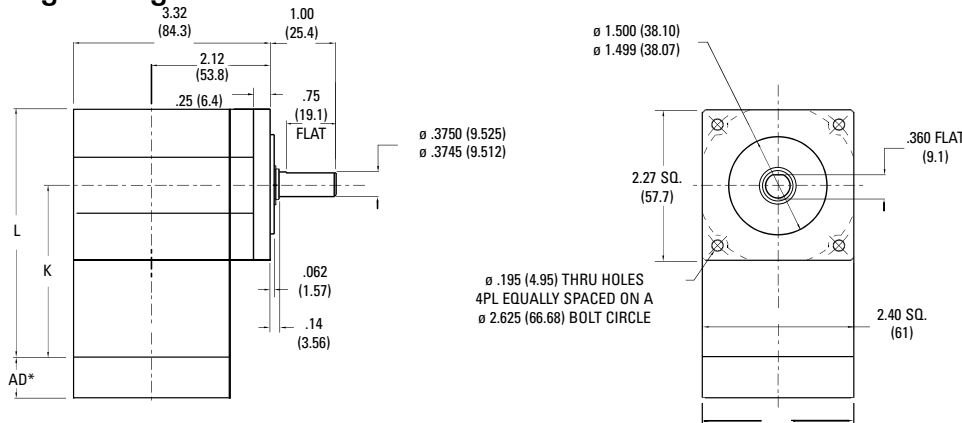

Ratio ¹	Dimension 'K' in [mm]	Dimension 'L' in [mm]	Backlash [arc-min]	Weight lb [kg]	Efficiency
1:1 to 5:1P	3.11 [79]	4.31 [109,5]	13 max	3.0 [1,4]	98%
5:1T to 50:1	3.79 [96]	4.99 [127]	15 max	3.4 [1,5]	93%
60:1 to 500:1	4.48 [114]	5.68 [144]	15 max	3.8 [1,6]	88%

Dimensions are inch (mm)
AD** = Adapter length
Adapter length will vary depending on motor.
Efficiency is calculated at 100% of the rated torque.

Performance Specifications

Part Number	Ratio ¹	10000 Hour Life			T _{peak} in-lb [Nm]	20000 Hour Life			J in-lb-sec ² x10 ⁻⁴ [kg-cm ²]	Torsional Stiffness in-lb/arc-min [Nm/arc-min]
		T _r (1000 rpm) in-lb [Nm]	T _r (3000 rpm) in-lb [Nm]	T _r (5000 rpm) in-lb [Nm]		T _r (1000 rpm) in-lb [Nm]	T _r (3000 rpm) in-lb [Nm]	T _r (5000 rpm) in-lb [Nm]		
NTR23-001	1:1	59 [7]	54 [6]	49 [6]	195 [22]	54 [6]	50 [6]	45 [5]	7.01 [0,79]	5.6 [0,6]
NTR23-002	2:1	130 [15]	118 [13]	107 [12]	360 [41]	120 [14]	109 [12]	99 [11]	3.59 [0,41]	8.5 [1,0]
NTR23-003	3:1	83 [9]	75 [9]	68 [8]	270 [31]	76 [9]	70 [8]	63 [7]	3.09 [0,35]	9.6 [1,1]
NTR23-004	4:1	61 [7]	56 [6]	50 [6]	238 [27]	56 [6]	51 [6]	46 [5]	2.87 [0,32]	10.1 [1,1]
NTR23-005P	5:1P	50 [6]	46 [5]	41 [5]	180 [20]	46 [5]	42 [5]	38 [4]	2.81 [0,32]	10.3 [1,2]
NTR23-005T	5:1T	179 [20]	153 [17]	138 [16]	366 [41]	175 [20]	132 [15]	112 [13]	3.69 [0,42]	10.3 [1,2]
NTR23-006	6:1	153 [17]	130 [15]	126 [14]	366 [41]	149 [17]	120 [14]	116 [13]	3.67 [0,41]	6.7 [0,8]
NTR23-009	9:1	97 [11]	83 [9]	80 [9]	289 [33]	95 [11]	76 [9]	74 [8]	3.08 [0,35]	8.5 [1,0]
NTR23-010	10:1	157 [18]	144 [16]	130 [15]	366 [41]	155 [18]	138 [16]	120 [14]	3.48 [0,39]	6.6 [0,7]
NTR23-012	12:1	72 [8]	61 [7]	59 [7]	252 [28]	70 [8]	56 [6]	55 [6]	2.95 [0,33]	9.3 [1,1]
NTR23-015	15:1	100 [11]	91 [10]	83 [9]	297 [34]	99 [11]	88 [10]	76 [9]	2.89 [0,33]	9.8 [1,1]
NTR23-020	20:1	74 [8]	67 [8]	61 [7]	366 [41]	73 [8]	64 [7]	56 [6]	2.76 [0,31]	9.3 [1,0]
NTR23-025	25:1	60 [7]	55 [6]	50 [6]	198 [22]	60 [7]	53 [6]	46 [5]	2.71 [0,31]	9.8 [1,1]
NTR23-030	30:1	102 [12]	98 [11]	94 [11]	305 [34]	102 [11]	96 [11]	90 [10]	2.83 [0,32]	8.0 [0,9]
NTR23-040	40:1	75 [9]	72 [8]	69 [8]	263 [30]	75 [8]	71 [8]	67 [8]	2.69 [0,30]	9.0 [1,0]
NTR23-050	50:1	62 [7]	59 [7]	57 [6]	203 [23]	61 [7]	58 [7]	55 [6]	2.64 [0,30]	9.6 [1,1]
NTR23-060	60:1	163 [18]	161 [18]	158 [18]	366 [41]	163 [18]	160 [18]	157 [18]	3.68 [0,42]	6.5 [0,7]
NTR23-075	75:1	104 [12]	102 [12]	100 [11]	311 [35]	103 [12]	101 [11]	99 [11]	2.95 [0,33]	8.4 [0,9]
NTR23-090	90:1	104 [12]	102 [12]	101 [11]	313 [35]	103 [12]	102 [11]	100 [11]	3.09 [0,35]	8.3 [0,9]
NTR23-100	100:1	163 [18]	162 [18]	161 [18]	366 [41]	163 [18]	161 [18]	160 [18]	3.50 [0,40]	6.5 [0,7]
NTR23-120	120:1	76 [9]	75 [9]	74 [8]	270 [31]	76 [9]	75 [8]	73 [8]	2.96 [0,33]	9.2 [1,0]
NTR23-125	125:1	63 [7]	62 [7]	60 [7]	207 [23]	62 [7]	61 [7]	60 [7]	2.76 [0,31]	9.7 [1,1]
NTR23-150	150:1	104 [12]	103 [12]	102 [12]	316 [36]	104 [12]	103 [12]	102 [11]	2.91 [0,33]	8.4 [0,9]
NTR23-200	200:1	164 [19]	163 [18]	162 [18]	366 [41]	164 [18]	163 [18]	162 [18]	3.43 [0,39]	6.1 [0,7]
NTR23-250	250:1	63 [7]	62 [7]	62 [7]	207 [23]	63 [7]	62 [7]	61 [7]	2.72 [0,31]	9.7 [1,1]
NTR23-300	300:1	104 [12]	104 [12]	103 [12]	319 [36]	104 [12]	104 [12]	103 [12]	2.84 [0,32]	8.0 [0,9]
NTR23-400	400:1	77 [9]	76 [9]	76 [9]	274 [31]	77 [9]	76 [9]	76 [9]	2.71 [0,31]	9.0 [1,0]
NTR23-500	500:1	63 [7]	63 [7]	62 [7]	207 [23]	63 [7]	63 [7]	62 [7]	2.66 [0,30]	9.6 [1,1]

Ratio 5P is designed using only PowerTRUE face gearing technology.
Ratio 5T adds a True Planetary gearing stage for increased torque capacity.
¹ Ratios are exact, higher ratios and other custom options are also available, consult factory.

T_r = Rated output torque at rated speed for specific hours of life.
J = Mass moment of inertia reflected to the input shaft (including pinion assembly)
T_{peak} = Allowable momentary peak torque for emergency stop or heavy shock loading.

NemaTRUE™ 90 Size 34

Right Angle Gearheads

English

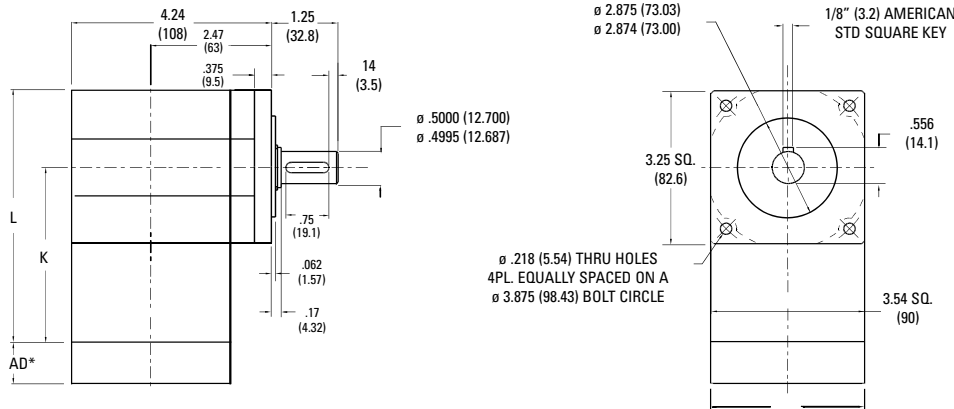

Ratio ¹	Dimension 'K' in [mm]	Dimension 'L' in [mm]	Backlash [arc-min]	Weight lb [kg]	Efficiency
1:1 to 5:1P	3.99 [101]	5.76 [146]	13 max	6.0 [2,7]	98%
5:1T to 50:1	4.89 [124]	6.66 [169]	15 max	7.4 [3,4]	93%
60:1 to 500:1	5.79 [147]	7.56 [192]	15 max	8.8 [4,0]	88%

Dimensions are inch (mm)
AD** = Adapter length
Adapter length will vary depending on motor.
Efficiency is calculated at 100% of the rated torque.

Performance Specifications

Part Number	Ratio ¹	10000 Hour Life			T _{peak} in-lb [Nm]	20000 Hour Life			J in-lb-sec ² x10 ⁻⁴ [kg-cm ²]	Torsional Stiffness in-lb/arc-min [Nm/arc-min]
		T _r (1000 rpm) in-lb [Nm]	T _r (3000 rpm) in-lb [Nm]	T _r (5000 rpm) in-lb [Nm]		T _r (1000 rpm) in-lb [Nm]	T _r (3000 rpm) in-lb [Nm]	T _r (5000 rpm) in-lb [Nm]		
NTR34-001	1:1	168 [19]	153 [17]	139 [16]	493 [56]	155 [18]	142 [16]	128 [14]	27.5 [3,11]	12.6 [1,4]
NTR34-002	2:1	381 [43]	348 [39]	315 [36]	1113 [126]	352 [40]	321 [36]	291 [33]	14.1 [1,59]	19.1 [2,2]
NTR34-003	3:1	251 [28]	229 [26]	207 [23]	905 [102]	232 [26]	212 [24]	192 [22]	12.1 [1,37]	21.5 [2,4]
NTR34-004	4:1	192 [22]	176 [20]	159 [18]	695 [79]	178 [20]	162 [18]	147 [17]	11.2 [1,27]	22.6 [2,5]
NTR34-005P	5:1P	142 [16]	129 [15]	117 [13]	581 [66]	131 [15]	119 [13]	108 [12]	11.0 [1,25]	23.1 [2,6]
NTR34-005T	5:1T	508 [57]	432 [49]	420 [47]	1113 [126]	497 [56]	399 [45]	387 [44]	14.5 [1,64]	23.1 [2,6]
NTR34-006	6:1	448 [51]	381 [43]	370 [42]	1113 [126]	439 [50]	352 [40]	342 [39]	14.4 [1,63]	15.0 [1,7]
NTR34-009	9:1	296 [33]	251 [28]	244 [28]	986 [111]	289 [33]	232 [26]	225 [25]	12.1 [1,37]	19.0 [2,1]
NTR34-010	10:1	462 [52]	422 [48]	381 [43]	1113 [126]	456 [52]	404 [46]	352 [40]	13.7 [1,54]	14.8 [1,7]
NTR34-012	12:1	226 [26]	192 [22]	187 [21]	752 [85]	221 [25]	178 [20]	173 [19]	11.6 [1,31]	20.9 [2,4]
NTR34-015	15:1	305 [34]	278 [31]	251 [28]	1018 [115]	301 [34]	266 [30]	232 [26]	11.3 [1,28]	21.9 [2,5]
NTR34-020	20:1	233 [26]	213 [24]	192 [22]	1113 [126]	230 [26]	204 [23]	178 [20]	10.8 [1,22]	20.8 [2,4]
NTR34-025	25:1	172 [19]	157 [18]	142 [16]	635 [72]	169 [19]	150 [17]	131 [15]	10.6 [1,20]	21.9 [2,5]
NTR34-030	30:1	311 [35]	298 [34]	285 [32]	1045 [118]	309 [35]	292 [33]	275 [31]	11.1 [1,25]	17.9 [2,0]
NTR34-040	40:1	238 [27]	228 [26]	218 [25]	792 [89]	237 [27]	224 [25]	210 [24]	10.6 [1,19]	20.2 [2,3]
NTR34-050	50:1	175 [20]	168 [19]	160 [18]	653 [74]	174 [20]	165 [19]	155 [18]	10.4 [1,17]	21.4 [2,4]
NTR34-060	60:1	479 [54]	472 [53]	465 [53]	1113 [126]	478 [54]	469 [53]	460 [52]	14.4 [1,63]	14.5 [1,6]
NTR34-075	75:1	315 [36]	310 [35]	305 [34]	1080 [122]	314 [36]	308 [35]	301 [34]	11.6 [1,31]	18.7 [2,1]
NTR34-090	90:1	316 [36]	311 [35]	307 [35]	1085 [123]	315 [36]	309 [35]	304 [34]	12.1 [1,37]	18.6 [2,1]
NTR34-100	100:1	480 [54]	476 [54]	472 [53]	1113 [126]	479 [54]	474 [54]	469 [53]	13.7 [1,55]	14.6 [1,7]
NTR34-120	120:1	242 [27]	238 [27]	235 [27]	817 [92]	241 [27]	237 [27]	232 [26]	11.6 [1,31]	20.7 [2,3]
NTR34-125	125:1	178 [20]	175 [20]	172 [19]	666 [75]	177 [20]	173 [20]	169 [19]	10.8 [1,23]	21.8 [2,5]
NTR34-150	150:1	317 [36]	314 [35]	311 [35]	1096 [124]	316 [36]	313 [35]	309 [35]	11.4 [1,29]	18.7 [2,1]
NTR34-200	200:1	481 [54]	479 [54]	477 [54]	1113 [126]	481 [54]	478 [54]	475 [54]	13.5 [1,52]	13.6 [1,5]
NTR34-250	250:1	178 [20]	177 [20]	175 [20]	675 [76]	178 [20]	176 [20]	174 [20]	10.7 [1,21]	21.8 [2,5]
NTR34-300	300:1	317 [36]	316 [36]	315 [36]	1107 [125]	317 [36]	315 [36]	314 [35]	11.1 [1,26]	17.9 [2,0]
NTR34-400	400:1	243 [27]	242 [27]	241 [27]	832 [94]	243 [27]	241 [27]	240 [27]	10.6 [1,20]	20.2 [2,3]
NTR34-500	500:1	179 [20]	178 [20]	177 [20]	680 [77]	179 [20]	178 [20]	177 [20]	10.4 [1,18]	21.4 [2,4]

Ratio 5P is designed using only PowerTRUE face gearing technology.

Ratio 5T adds a True Planetary gearing stage for increased torque capacity.

¹ Ratios are exact, higher ratios and other custom options are also available, consult factory.

T_r = Rated output torque at rated speed for specific hours of life.

J = Mass moment of inertia reflected to the input shaft (including pinion assembly)

T_{peak} = Allowable momentary peak torque for emergency stop or heavy shock loading.

NemaTRUE™ 90 Size 42

Right Angle Gearheads

English

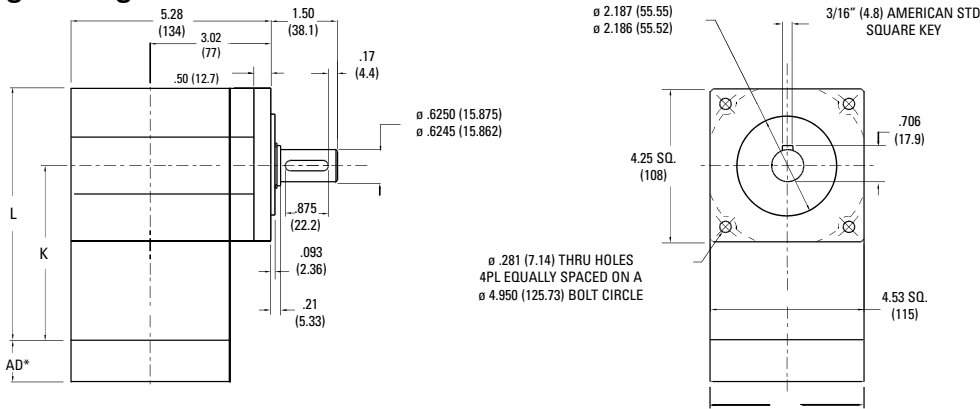

Ratio ¹	Dimension 'K' in [mm]	Dimension 'L' in [mm]	Backlash [arc-min]	Weight lb [kg]	Efficiency
1:1 to 5:1P	5.40 [137]	7.67 [195]	13 max	12 [5,4]	98%
5:1T to 50:1	6.63 [168,4]	8.90 [226]	15 max	14.8 [6,7]	93%
60:1 to 500:1	7.87 [200]	10.13 [257]	15 max	17.6 [8,0]	88%

Dimensions are inch (mm)
AD** = Adapter length
Adapter length will vary depending on motor.
Efficiency is calculated at 100% of the rated torque.

Performance Specifications

Part Number	Ratio ¹	10000 Hour Life			T _{peak} in-lb [Nm]	20000 Hour Life			J in-lb-sec ² x10 ⁻⁴ [kg-cm ²]	Torsional Stiffness in-lb/arc-min [Nm/arc-min]
		T _r (1000 rpm) in-lb [Nm]	T _r (3000 rpm) in-lb [Nm]	T _r (5000 rpm) in-lb [Nm]		T _r (1000 rpm) in-lb [Nm]	T _r (3000 rpm) in-lb [Nm]	T _r (5000 rpm) in-lb [Nm]		
NTR42-001	1:1	496 [56]	452 [51]	409 [46]	1620 [183]	458 [52]	418 [47]	378 [43]	46.7 [5,28]	15.0 [1,7]
NTR42-002	2:1	885 [100]	808 [91]	730 [83]	2255 [255]	817 [92]	746 [84]	674 [76]	23.9 [2,71]	24.7 [2,8]
NTR42-003	3:1	687 [78]	627 [71]	567 [64]	2039 [230]	635 [72]	579 [65]	524 [59]	20.6 [2,33]	28.0 [3,2]
NTR42-004	4:1	458 [52]	418 [47]	378 [43]	1584 [179]	423 [48]	386 [44]	349 [39]	19.1 [2,16]	29.4 [3,3]
NTR42-005P	5:1P	343 [39]	313 [35]	283 [32]	1305 [147]	317 [36]	289 [33]	261 [30]	18.8 [2,12]	30.0 [3,4]
NTR42-005T	5:1T	1346 [152]	1117 [126]	958 [108]	2255 [255]	1262 [143]	907 [102]	778 [88]	24.6 [2,78]	30.0 [3,4]
NTR42-006	6:1	1041 [118]	885 [100]	859 [97]	2255 [255]	1018 [115]	817 [92]	794 [90]	24.5 [2,77]	20.1 [2,3]
NTR42-009	9:1	808 [91]	687 [78]	667 [75]	2241 [253]	791 [89]	635 [72]	616 [70]	20.5 [2,32]	25.1 [2,8]
NTR42-010	10:1	1072 [121]	979 [111]	885 [100]	2255 [255]	1059 [120]	938 [106]	817 [92]	23.2 [2,63]	20.1 [2,3]
NTR42-012	12:1	538 [61]	458 [52]	444 [50]	1728 [195]	526 [59]	423 [48]	410 [46]	19.6 [2,22]	27.5 [3,1]
NTR42-015	15:1	832 [94]	760 [86]	687 [78]	2255 [255]	822 [93]	728 [82]	635 [72]	19.3 [2,18]	28.8 [3,3]
NTR42-020	20:1	554 [63]	506 [57]	458 [52]	2255 [255]	547 [62]	485 [55]	423 [48]	18.4 [2,08]	27.5 [3,1]
NTR42-025	25:1	416 [47]	379 [43]	343 [39]	1458 [165]	410 [46]	364 [41]	317 [36]	18.0 [2,04]	28.8 [3,2]
NTR42-030	30:1	851 [96]	814 [92]	778 [88]	2255 [255]	845 [96]	798 [90]	752 [85]	18.9 [2,13]	24.6 [2,8]
NTR42-040	40:1	566 [64]	542 [61]	518 [59]	1836 [207]	563 [64]	532 [60]	500 [57]	18.0 [2,03]	27.2 [3,1]
NTR42-050	50:1	425 [48]	407 [46]	388 [44]	1499 [169]	422 [48]	399 [45]	375 [42]	17.6 [1,99]	28.5 [3,2]
NTR42-060	60:1	1111 [126]	1095 [124]	1080 [122]	2255 [255]	1109 [125]	1089 [123]	1069 [121]	24.6 [2,78]	19.7 [2,2]
NTR42-075	75:1	861 [97]	847 [96]	832 [94]	2255 [255]	859 [97]	841 [95]	822 [93]	19.7 [2,22]	25.0 [2,8]
NTR42-090	90:1	863 [97]	851 [96]	838 [95]	2255 [255]	861 [97]	845 [96]	830 [94]	20.6 [2,33]	24.8 [2,8]
NTR42-100	100:1	1114 [126]	1105 [125]	1095 [124]	2255 [255]	1113 [126]	1101 [124]	1089 [123]	23.3 [2,64]	19.9 [2,2]
NTR42-120	120:1	574 [65]	566 [64]	558 [63]	1897 [214]	573 [65]	563 [64]	552 [62]	19.7 [2,23]	27.3 [3,1]
NTR42-125	125:1	430 [49]	423 [48]	416 [47]	1539 [174]	429 [48]	420 [47]	410 [46]	18.4 [2,08]	28.7 [3,2]
NTR42-150	150:1	865 [98]	858 [97]	851 [96]	2255 [255]	864 [98]	855 [97]	845 [96]	19.4 [2,19]	25.0 [2,8]
NTR42-200	200:1	1116 [126]	1112 [126]	1107 [125]	2255 [255]	1116 [126]	1110 [125]	1104 [125]	22.9 [2,59]	19.4 [2,2]
NTR42-250	250:1	432 [49]	428 [48]	425 [48]	1562 [176]	431 [49]	427 [48]	422 [48]	18.1 [2,05]	28.7 [3,2]
NTR42-300	300:1	867 [98]	863 [98]	860 [97]	2255 [255]	866 [98]	862 [97]	857 [97]	18.9 [2,14]	24.6 [2,8]
NTR42-400	400:1	577 [65]	575 [65]	572 [65]	1944 [220]	577 [65]	574 [65]	571 [64]	18.1 [2,04]	27.1 [3,1]
NTR42-500	500:1	433 [49]	431 [49]	429 [48]	1580 [178]	433 [49]	430 [49]	428 [48]	17.7 [2,00]	28.5 [3,2]

Ratio 5P is designed using only PowerTRUE face gearing technology.

Ratio 5T adds a True Planetary gearing stage for increased torque capacity.

¹ Ratios are exact, higher ratios and other custom options are also available, consult factory.

T_r = Rated output torque at rated speed for specific hours of life.

J = Mass moment of inertia reflected to the input shaft (including pinion assembly)

T_{peak} = Allowable momentary peak torque for emergency stop or heavy shock loading.

Radial and Axial Load Ratings

NTR23

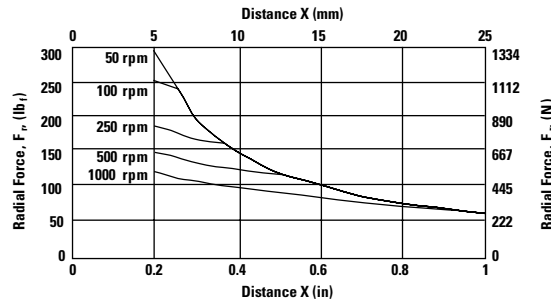
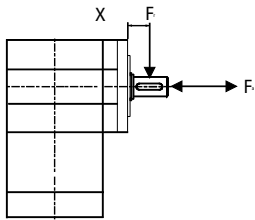

Speed rpm	Axial Load, F_a lb _f [N]
50	250 [1110]
100	200 [890]
250	150 [670]
500	120 [530]
1000	90 [400]

NTR34

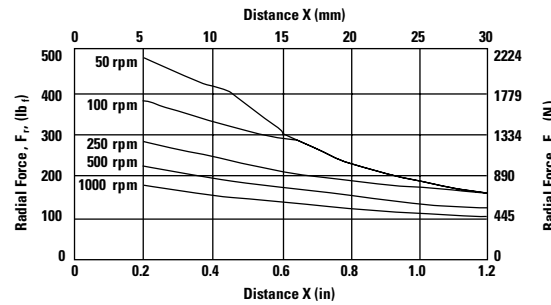
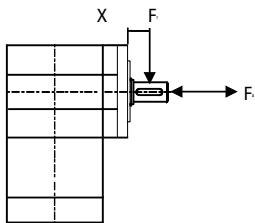

Speed rpm	Axial Load, F_a lb _f [N]
50	340 [1510]
100	270 [1200]
250	200 [890]
500	160 [710]
1000	130 [580]

NTR42

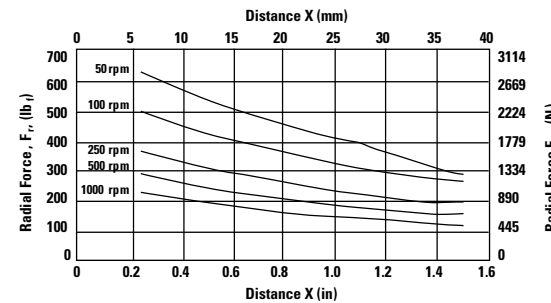
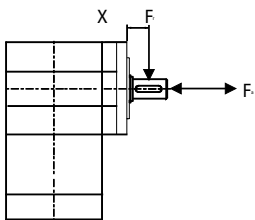

Speed rpm	Axial Load, F_a lb _f [N]
50	460 [2050]
100	370 [1650]
250	270 [1200]
500	210 [930]
1000	170 [760]

These graphs display the allowable radial load at a given distance (X) from the mounting surface based on an L_{10} life of 10,000 hours for the mean output speed n_{mout} , as described on page 10,



DuraTRUE™

True Planetary™ Gearheads

Ready for Immediate Delivery	
Precision	8 arc-minutes
Frame Sizes	60mm, 90mm, 115mm and 142mm
Torque Capacity	up to 834 Nm
Ratio Availability	3:1 thru 100:1
Radial load capacity	up to 11150 N
Mounting System	RediMount™

- ① **Sealed deep groove ball bearings**
provide high radial load carrying capability
- ② **HRC 55-60 steel gears**
provide superior wear resistance
and increased backlash integrity
- ③ **Sealed deep groove ball bearing**
provides precision alignment of sun gear
- ④ **RediMount™ system**
provides error-free motor installation
- ⑤ **Anodized aluminum housing**
reduces weight and prevents corrosion

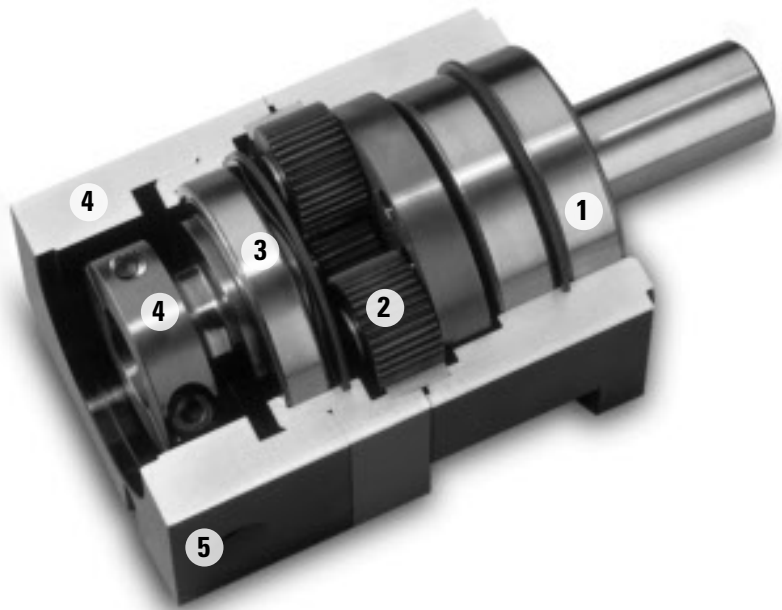

**Micron True Planetary™ Gearheads
shipped within 24 hours!**



**Need it fast? Go to the back cover
of the catalog for details.**

DuraTRUE™ Size 60

True Planetary™ Gearheads

Metric

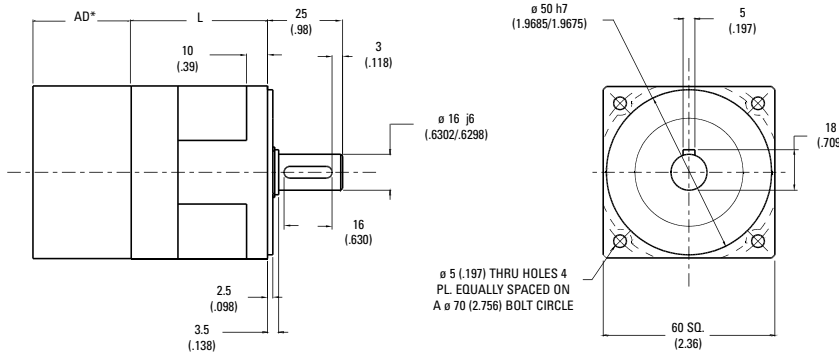

Ratio ¹	Dimension 'L' mm [in]	Backlash [arc-min]	Weight kg [lb]	Efficiency
3:1 to 10:1	53 [2.07]	8 max	1,0 [2.2]	93%
15:1 to 100:1	70 [2.76]	9 max	1,2 [2.7]	88%

All dimensions are: mm (inch)
 AD** = Adapter length
 Adapter length will vary depending on motor.
 Efficiency is calculated at 100% of the rated torque.

Performance Specifications

Part Number	Ratio ¹	10000 Hour Life				T _{peak} Nm [in-lb]	20000 Hour Life				J kg-cm ² [in-lb-sec ² x10 ⁻⁴]	Torsional Stiffness Nm/arc-min [in-lb/arc-min]
		T _r (1000 rpm) Nm [in-lb]	T _r (2000 rpm) Nm [in-lb]	T _r (3000 rpm) Nm [in-lb]	T _r (4000 rpm) Nm [in-lb]		T _r (1000 rpm) Nm [in-lb]	T _r (2000 rpm) Nm [in-lb]	T _r (3000 rpm) Nm [in-lb]	T _r (4000 rpm) Nm [in-lb]		
DT60-003	3:1	15 [134]	12 [109]	11 [97]	89 [10]	52 [460]	12 [109]	10 [89]	9 [79]	8 [72]	0,52 [4.6]	0,9 [8.1]
DT60-004	4:1	19 [168]	16 [142]	14 [124]	115 [13]	44 [385]	16 [142]	13 [115]	12 [106]	11 [97]	0,46 [4.1]	0,9 [7.9]
DT60-005	5:1	17 [148]	14 [120]	12 [106]	98 [11]	46 [410]	14 [120]	11 [98]	10 [86]	9 [79]	0,46 [4.1]	0,9 [7.9]
DT60-007	7:1	16 [142]	13 [115]	11 [97]	89 [10]	41 [363]	13 [115]	10 [89]	9 [80]	8 [71]	0,46 [4.1]	0,9 [7.9]
DT60-010	10:1	15 [134]	14 [121]	13 [114]	108 [12]	45 [400]	14 [124]	13 [112]	11 [100]	10 [92]	0,44 [3.9]	0,8 [6.8]
DT60-015	15:1	25 [218]	20 [177]	18 [157]	144 [16]	52 [460]	20 [177]	16 [144]	14 [127]	13 [117]	0,46 [4.1]	0,9 [8.2]
DT60-020	20:1	26 [230]	24 [212]	21 [186]	177 [20]	46 [407]	24 [212]	20 [177]	18 [159]	17 [150]	0,46 [4.1]	0,9 [7.9]
DT60-025	25:1	24 [214]	22 [195]	19 [172]	158 [18]	52 [456]	22 [195]	18 [158]	16 [140]	15 [128]	0,46 [4.1]	0,9 [8.3]
DT60-030	30:1	28 [246]	25 [218]	22 [193]	177 [20]	52 [460]	25 [218]	20 [177]	18 [157]	16 [144]	0,44 [3.9]	1,0 [8.7]
DT60-040	40:1	27 [239]	26 [230]	26 [230]	212 [24]	46 [407]	27 [239]	24 [212]	21 [186]	20 [177]	0,44 [3.9]	0,9 [8.3]
DT60-050	50:1	25 [222]	24 [214]	24 [209]	195 [22]	52 [460]	25 [217]	22 [195]	19 [172]	18 [158]	0,44 [3.9]	0,9 [8.2]
DT60-070	70:1	24 [212]	23 [204]	23 [204]	186 [21]	46 [407]	24 [212]	21 [186]	18 [159]	17 [150]	0,44 [3.9]	0,9 [8.3]
DT60-100	100:1	20 [180]	19 [165]	18 [157]	151 [17]	51 [447]	19 [167]	17 [153]	16 [145]	16 [140]	0,44 [3.9]	0,9 [7.8]

All ratios are available to ship in 24 hours through the Gearhead Express Program.

¹ Ratios are exact, higher ratios and other custom options are also available, consult factory.
 T_r = Rated output torque at rated speed for specific hours of life.

T_{peak} = Allowable momentary peak torque for emergency stop or heavy shock loading.
 J = Mass moment of inertia reflected to the input shaft (including pinion assembly).

DuraTRUE™ Size 90

True Planetary™ Gearheads

Metric

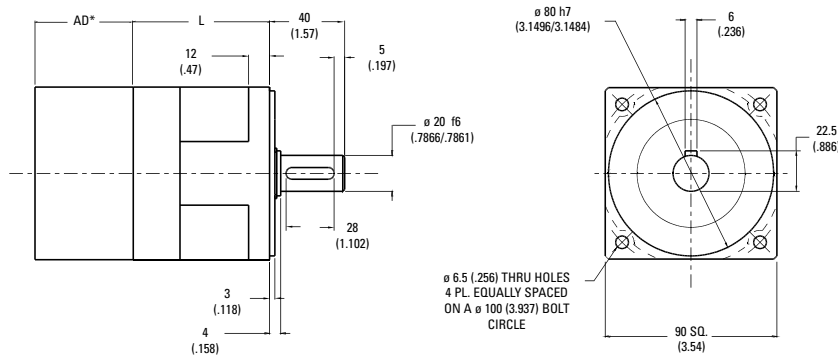

Ratio ¹	Dimension 'L' mm [in]	Backlash [arc-min]	Weight kg [lb]	Efficiency
3:1 to 10:1	67 [2.63]	8 max	3,0 [6.6]	93%
15:1 to 100:1	90 [3.53]	9 max	3,7 [8.1]	88%

All dimensions are: mm (inch)
 AD** = Adapter length
 Adapter length will vary depending on motor.
 Efficiency is calculated at 100% of the rated torque.

Performance Specifications

Part Number	Ratio ¹	10000 Hour Life				T _{peak} Nm [in-lb]	20000 Hour Life				J kg-cm ² [in-lb-sec ² x10 ⁻⁴]	Torsional Stiffness Nm/arc-min [in-lb/arc-min]
		T _r (1000 rpm) Nm [in-lb]	T _r (2000 rpm) Nm [in-lb]	T _r (3000 rpm) Nm [in-lb]	T _r (4000 rpm) Nm [in-lb]		T _r (1000 rpm) Nm [in-lb]	T _r (2000 rpm) Nm [in-lb]	T _r (3000 rpm) Nm [in-lb]	T _r (4000 rpm) Nm [in-lb]		
DT90-003	3:1	69 [614]	56 [499]	50 [442]	46 [405]	167 [1479]	56 [499]	46 [405]	41 [359]	37 [329]	2,22 [1.97]	4,9 [43.3]
DT90-004	4:1	80 [708]	67 [593]	60 [531]	55 [487]	157 [1389]	67 [593]	55 [487]	50 [443]	46 [407]	1,84 [1.60]	4,8 [42.4]
DT90-005	5:1	75 [664]	62 [549]	55 [486]	50 [446]	157 [1385]	62 [549]	50 [446]	45 [395]	41 [362]	1,76 [1.56]	4,8 [42.9]
DT90-007	7:1	73 [646]	60 [531]	53 [469]	48 [425]	157 [1389]	60 [531]	48 [425]	43 [381]	38 [336]	1,72 [1.50]	4,8 [42.4]
DT90-010	10:1	55 [488]	50 [439]	46 [411]	44 [392]	157 [1390]	51 [452]	46 [407]	43 [381]	41 [363]	1,63 [1.44]	4,0 [35.6]
DT90-015	15:1	93 [826]	84 [747]	79 [702]	74 [657]	167 [1479]	86 [764]	74 [657]	66 [582]	60 [534]	1,78 [1.58]	4,9 [43.7]
DT90-020	20:1	89 [788]	86 [761]	84 [743]	82 [726]	167 [1478]	88 [779]	84 [743]	77 [681]	71 [628]	1,77 [1.60]	4,8 [42.4]
DT90-025	25:1	84 [747]	81 [714]	78 [693]	77 [677]	167 [1479]	83 [730]	79 [698]	72 [640]	66 [587]	1,77 [1.56]	5,0 [44.5]
DT90-030	30:1	103 [908]	93 [826]	88 [780]	84 [747]	167 [1479]	95 [840]	86 [764]	81 [716]	74 [657]	1,64 [1.45]	4,9 [43.4]
DT90-040	40:1	93 [823]	89 [788]	87 [770]	86 [761]	167 [1478]	91 [805]	88 [779]	86 [761]	84 [743]	1,64 [1.40]	5,0 [44.2]
DT90-050	50:1	88 [776]	84 [747]	82 [728]	81 [714]	167 [1479]	86 [759]	83 [730]	81 [712]	79 [698]	1,63 [1.45]	5,0 [44.2]
DT90-070	70:1	86 [761]	82 [726]	80 [708]	79 [699]	167 [1478]	84 [743]	81 [717]	79 [699]	78 [690]	1,63 [1.40]	5,0 [44.2]
DT90-100	100:1	75 [663]	69 [608]	65 [576]	63 [555]	167 [1479]	69 [613]	64 [562]	60 [533]	58 [513]	1,63 [1.45]	4,4 [38.5]

All ratios are available to ship in 24 hours through the Gearhead Express Program.

¹ Ratios are exact, higher ratios and other custom options are also available, consult factory.
 T_r = Rated output torque at rated speed for specific hours of life.

T_{peak} = Allowable momentary peak torque for emergency stop or heavy shock loading.
 J = Mass moment of inertia reflected to the input shaft (including pinion assembly).

DuraTRUE™ Size 115

True Planetary™ Gearheads

Metric

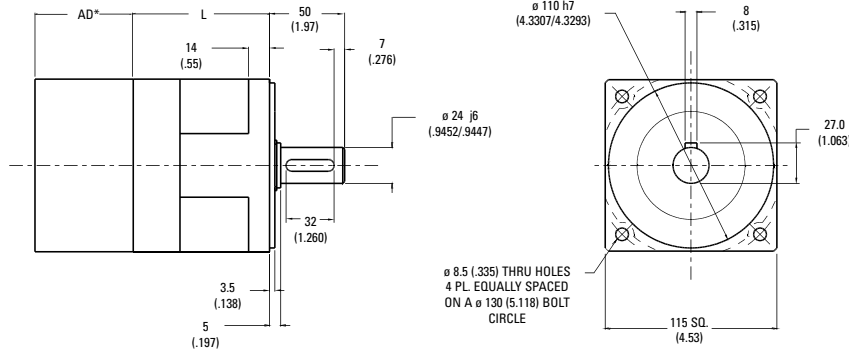

Ratio ¹	Dimension 'L' mm [in]	Backlash [arc-min]	Weight kg [lb]	Efficiency
3:1 to 10:1	88 [3.46]	8 max	5,7 [12.7]	93%
15:1 to 100:1	119 [4.69]	9 max	7,3 [16.2]	88%

All dimensions are: mm (inch)
 AD** = Adapter length
 Adapter length will vary depending on motor.
 Efficiency is calculated at 100% of the rated torque.

Performance Specifications

Part Number	Ratio ¹	10000 Hour Life				T _{peak} Nm [in-lb]	20000 Hour Life				J kg-cm ² [in-lb-sec ² x10 ⁻⁴]	Torsional Stiffness Nm/arc-min [in-lb/arc-min]
		T _r (1000 rpm) Nm [in-lb]	T _r (2000 rpm) Nm [in-lb]	T _r (3000 rpm) Nm [in-lb]	T _r (4000 rpm) Nm [in-lb]		T _r (1000 rpm) Nm [in-lb]	T _r (2000 rpm) Nm [in-lb]	T _r (3000 rpm) Nm [in-lb]	T _r (4000 rpm) Nm [in-lb]		
DT115-003	3:1	105 [932]	86 [757]	76 [670]	70 [615]	284 [2511]	86 [757]	70 [615]	62 [544]	56 [499]	4,39 [3.88]	13,9 [123.4]
DT115-004	4:1	123 [1089]	98 [867]	91 [805]	85 [752]	284 [2513]	102 [903]	85 [752]	75 [664]	70 [620]	3,1 [2.7]	13,9 [122.7]
DT115-005	5:1	116 [1025]	91 [803]	83 [738]	77 [677]	284 [2511]	94 [833]	77 [677]	68 [599]	62 [550]	2,88 [2.55]	11,6 [102.4]
DT115-007	7:1	113 [1000]	88 [779]	81 [717]	75 [664]	284 [2513]	92 [814]	75 [664]	65 [575]	60 [531]	2,81 [2.5]	13,9 [122.7]
DT115-010	10:1	90 [796]	81 [715]	76 [668]	72 [635]	284 [2511]	83 [737]	75 [661]	70 [618]	66 [588]	2,47 [2.18]	11,6 [102.4]
DT115-015	15:1	171 [1510]	139 [1226]	123 [1086]	113 [996]	284 [2511]	139 [1226]	113 [996]	100 [882]	91 [809]	2,95 [2.61]	12,9 [114.1]
DT115-020	20:1	175 [1549]	161 [1425]	143 [1266]	132 [1168]	284 [2513]	161 [1425]	132 [1168]	118 [1044]	109 [965]	2,95 [2.6]	13,9 [122.7]
DT115-025	25:1	167 [1474]	153 [1350]	135 [1195]	124 [1096]	284 [2511]	153 [1350]	124 [1096]	110 [971]	101 [891]	2,90 [2.57]	14,1 [125.0]
DT115-030	30:1	203 [1794]	171 [218]	151 [1337]	139 [1226]	284 [2513]	171 [1510]	139 [1226]	123 [1086]	113 [996]	2,48 [2.20]	14,1 [124.4]
DT115-040	40:1	181 [1602]	175 [1549]	190 [1682]	161 [1425]	284 [2513]	178 [1575]	161 [1425]	143 [1266]	132 [1168]	2,47 [2.2]	14,1 [124.4]
DT115-050	50:1	173 [1535]	167 [1474]	162 [1435]	153 [1350]	284 [2511]	170 [1510]	153 [1350]	135 [1195]	124 [1096]	2,47 [2.19]	14,1 [125.0]
DT115-070	70:1	171 [1513]	165 [1460]	180 [1593]	151 [1336]	284 [2513]	168 [1487]	151 [1336]	133 [1177]	122 [1080]	2,47 [2.2]	14,1 [124.4]
DT115-100	100:1	123 [1087]	112 [995]	107 [943]	103 [907]	284 [2511]	114 [1006]	104 [921]	99 [873]	95 [840]	2,47 [2.19]	11,4 [100.6]

All ratios are available to ship in 24 hours through the Gearhead Express Program.

¹ Ratios are exact, higher ratios and other custom options are also available, consult factory.
 T_r = Rated output torque at rated speed for specific hours of life.

T_{peak} = Allowable momentary peak torque for emergency stop or heavy shock loading.
 J = Mass moment of inertia reflected to the input shaft (including pinion assembly).

DuraTRUE™ Size 142

True Planetary™ Gearheads

Metric

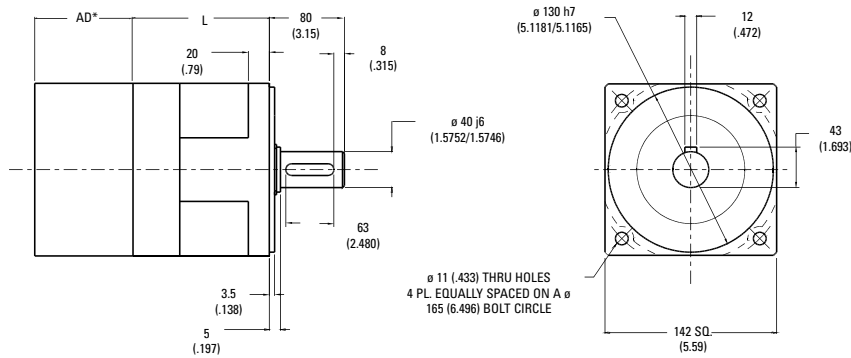

Ratio ¹	Dimension 'L' mm [in]	Backlash [arc-min]	Weight kg [lb]	Efficiency
3:1 to 10:1	121 [4.77]	8 max	12,8 [28.3]	93%
15:1 to 100:1	170 [6.71]	9 max	17,2 [38.0]	88%

All dimensions are: mm (inch)
 AD** = Adapter length
 Adapter length will vary depending on motor.
 Efficiency is calculated at 100% of the rated torque.

Performance Specifications

Part Number	Ratio ¹	10000 Hour Life				T _{peak} Nm [in-lb]	20000 Hour Life				J kg-cm ² [in-lb-sec ² x10 ⁻⁴]	Torsional Stiffness Nm/arc-min [in-lb/arc-min]
		T _r (1000 rpm) Nm [in-lb]	T _r (2000 rpm) Nm [in-lb]	T _r (3000 rpm) Nm [in-lb]	T _r (4000 rpm) Nm [in-lb]		T _r (1000 rpm) Nm [in-lb]	T _r (2000 rpm) Nm [in-lb]	T _r (3000 rpm) Nm [in-lb]	T _r (4000 rpm) Nm [in-lb]		
DT142-003	3:1	372 [3289]	302 [2671]	267 [2365]	245 [2170]	834 [7377]	302 [2671]	245 [2170]	217 [1921]	199 [1762]	23,2 [2.05]	51,8 [458.7]
DT142-004	4:1	430 [3806]	353 [3124]	315 [2788]	290 [2567]	834 [7381]	353 [3124]	290 [2567]	259 [2292]	239 [2115]	15,1 [1.3]	52,9 [467.1]
DT142-005	5:1	410 [3625]	333 [2944]	295 [2607]	270 [2391]	834 [7377]	333 [2944]	270 [2391]	239 [2118]	219 [1942]	14,7 [1.30]	52,6 [465.1]
DT142-007	7:1	405 [3584]	328 [2903]	290 [2597]	265 [2345]	834 [7381]	328 [2903]	265 [2345]	234 [2071]	214 [1894]	14,5 [1.3]	50,5 [445.9]
DT142-010	10:1	229 [2022]	204 [1808]	190 [1685]	181 [1598]	834 [7377]	211 [1871]	189 [1673]	176 [1559]	167 [1479]	12,1 [1.07]	41,3 [365.1]
DT142-015	15:1	524 [4634]	471 [4167]	433 [3833]	397 [3516]	834 [7377]	484 [4287]	397 [3516]	352 [3114]	323 [2856]	15,1 [1.34]	59,6 [527.6]
DT142-020	20:1	500 [4425]	476 [4213]	461 [4080]	450 [3983]	834 [7381]	489 [4328]	458 [4053]	408 [3611]	376 [3328]	14,8 [1.3]	58,5 [516.6]
DT142-025	25:1	480 [4248]	456 [4038]	441 [3903]	430 [3801]	834 [7377]	469 [4154]	438 [3876]	388 [3432]	356 [3148]	14,8 [1.31]	57,7 [510.6]
DT142-030	30:1	578 [5113]	524 [4634]	493 [4359]	471 [4167]	834 [7377]	535 [4731]	484 [4287]	433 [3833]	397 [3516]	12,2 [1.08]	59,9 [529.9]
DT142-040	40:1	521 [4611]	500 [4425]	486 [4301]	476 [4213]	834 [7381]	510 [4514]	489 [4328]	476 [4213]	458 [4053]	12,9 [1.1]	57,5 [507.7]
DT142-050	50:1	501 [4435]	480 [4248]	466 [4128]	456 [4038]	834 [7377]	490 [4336]	469 [4154]	456 [4037]	438 [3876]	12,1 [1.07]	57,8 [511.1]
DT142-070	70:1	496 [4390]	475 [4204]	461 [4080]	451 [3991]	834 [7381]	485 [4292]	464 [4106]	451 [3991]	433 [3882]	12,1 [1.1]	54,4 [480.4]
DT142-100	100:1	314 [2782]	287 [2543]	272 [2408]	262 [2314]	834 [7377]	291 [2574]	266 [2353]	252 [2228]	242 [2141]	12,1 [1.07]	42,9 [379.5]

All ratios are available to ship in 24 hours through the Gearhead Express Program.

¹ Ratios are exact, higher ratios and other custom options are also available, consult factory.
 T_r = Rated output torque at rated speed for specific hours of life.

T_{peak} = Allowable momentary peak torque for emergency stop or heavy shock loading.
 J = Mass moment of inertia reflected to the input shaft (including pinion assembly).

Radial and Axial Load Ratings

DT60

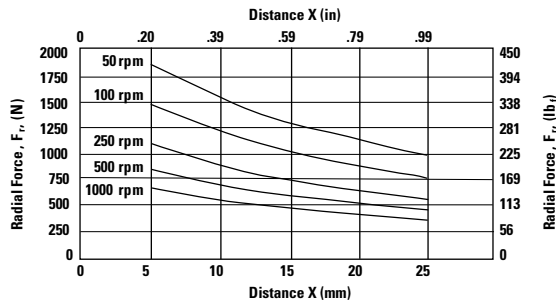
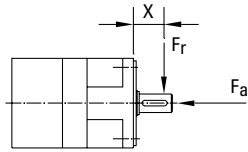

Speed rpm	Axial Load, F_a N [lb _f]
50	3075 [692]
100	2441 [549]
250	1798 [405]
500	1427 [321]
1000	1133 [255]

DT90

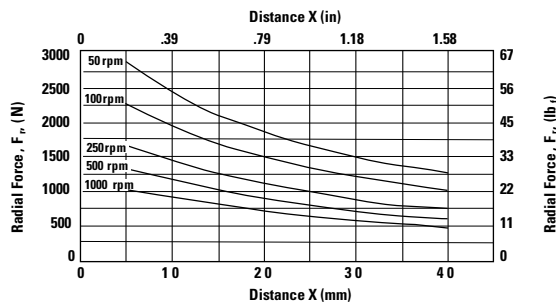
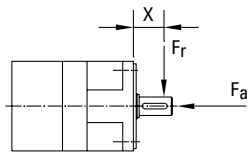

Speed rpm	Axial Load, F_a N [lb _f]
50	4506 [1014]
100	3576 [805]
250	2635 [593]
500	2091 [471]
1000	1660 [373]

DT115

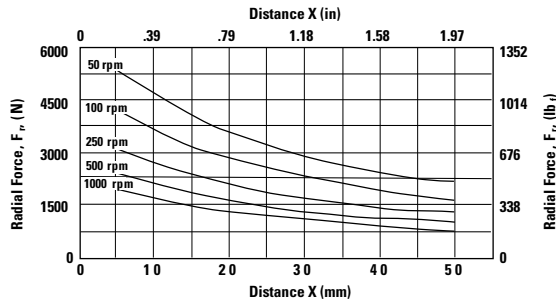
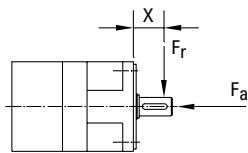

Speed rpm	Axial Load, F_a N [lb _f]
50	8196 [1844]
100	6505 [1464]
250	4793 [1078]
500	3804 [856]
1000	3019 [679]

DT142

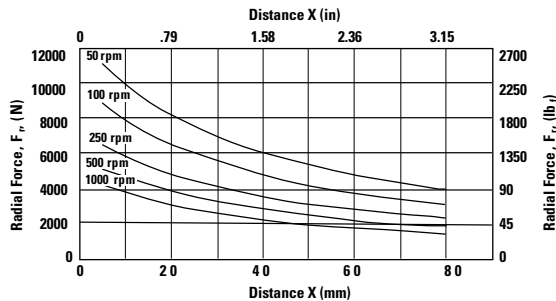
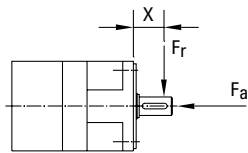

Speed rpm	Axial Load, F_a N [lb _f]
50	17023 [3830]
100	13511 [3040]
250	9956 [2240]
500	7902 [1778]
1000	6271 [1411]

These graphs display the allowable radial load at a given distance (X) from the mounting surface based on an L₁₀ life of 10,000 hours for the mean output speed n_{mout} , as described on page 10,

DuraTRUE 90™

Right Angle Gearheads

Ready for Immediate Delivery	
Precision	8 arc-minutes
Frame Sizes	60mm, 90mm, 115mm and 142mm
Torque Capacity	up to 865 Nm
Ratio Availability	1:1 thru 500:1
Radial load capacity	up to 11150 N
Mounting System	RediMount™

- ① **Deep Groove Ball bearings**
provide high radial load carrying capabilities
- ② **HRC 55-60 steel gears**
provide superior wear resistance and increased backlash integrity
- ③ **Innovative PowerTRUE™ gearing**
delivers smooth, quiet geared reduction
- ④ **RediMount™ system**
provides error-free installation

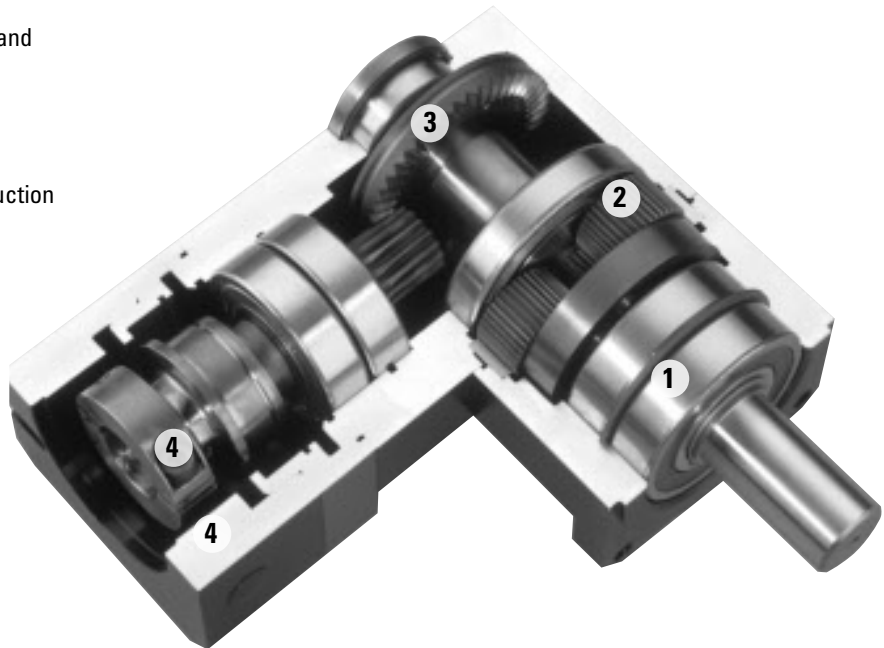

DuraTRUE 90™ Size 60

Right Angle Gearheads

Metric

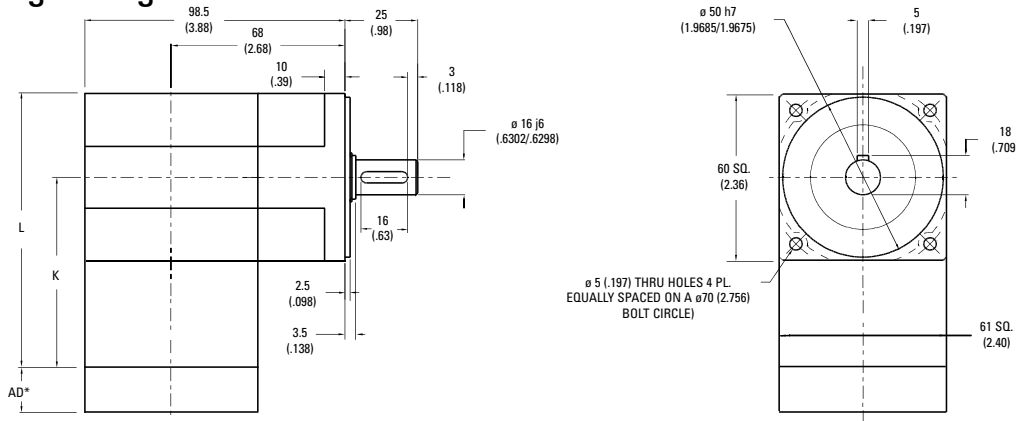

Ratio ¹	Dimension 'K' mm [in]	Dimension 'L' mm [in]	Backlash [arc-min]	Weight kg [lb]	Efficiency
5:1 to 50:1	79 [3.11]	109,5 [4.31]	9 max	2,5 [5.5]	93%
60:1 to 500:1	96 [3.79]	127 [4.99]	9 max	2,7 [6]	88%

All dimensions are: mm (inch)
 AD** = Adapter length
 Adapter length will vary depending on motor.
 Efficiency is calculated at 100% of the rated torque.

Performance Specifications

Part Number	Ratio ¹	10000 Hour Life			T _{peak} Nm [in-lb]	20000 Hour Life			J kg-cm ² [in-lb-sec ² x10 ⁻⁴]	Torsional Stiffness Nm/arc-min [in-lb/arc-min]
		T _r (1000 rpm) Nm [in-lb]	T _r (3000 rpm) Nm [in-lb]	T _r (5000 rpm) Nm [in-lb]		T _r (1000 rpm) Nm [in-lb]	T _r (3000 rpm) Nm [in-lb]	T _r (5000 rpm) Nm [in-lb]		
DTR60-005	5:1	18 [157]	13 [113]	11 [97]	52 [460]	14 [127]	10 [92]	9 [79]	0,42 [3.7]	2,3 [20.1]
DTR60-006	6:1	19 [166]	13 [119]	12 [102]	52 [460]	15 [134]	11 [97]	9 [83]	0,42 [3.7]	2,3 [20.3]
DTR60-009	9:1	21 [187]	15 [134]	13 [115]	52 [460]	17 [152]	12 [109]	11 [94]	0,36 [3.1]	2,3 [20.2]
DTR60-010	10:1	21 [182]	15 [131]	13 [112]	49 [435]	17 [148]	12 [106]	10 [91]	0,41 [3.5]	2,3 [20.2]
DTR60-012	12:1	18 [161]	17 [147]	14 [126]	45 [402]	18 [161]	13 [119]	12 [102]	0,33 [3.0]	2,3 [20.4]
DTR60-015	15:1	23 [206]	17 [148]	14 [127]	50 [445]	19 [167]	14 [120]	12 [103]	0,32 [2.9]	2,3 [20.4]
DTR60-020	20:1	24 [211]	18 [161]	16 [138]	51 [450]	21 [182]	15 [131]	13 [112]	0,33 [2.8]	2,3 [20.3]
DTR60-025	25:1	24 [214]	19 [172]	17 [148]	51 [455]	22 [195]	16 [140]	14 [120]	0,32 [2.7]	2,3 [20.3]
DTR60-030	30:1	18 [155]	15 [134]	14 [124]	49 [430]	16 [143]	14 [124]	13 [115]	0,35 [2.8]	1,7 [14.8]
DTR60-040	40:1	18 [161]	16 [139]	15 [130]	49 [430]	17 [149]	15 [129]	14 [120]	0,32 [2.7]	1,7 [14.8]
DTR60-050	50:1	19 [165]	16 [143]	15 [134]	49 [430]	17 [153]	15 [133]	14 [124]	0,32 [2.6]	1,7 [14.8]
DTR60-060	60:1	28 [244]	18 [155]	15 [133]	52 [460]	20 [175]	14 [126]	12 [108]	0,42 [3.7]	2,3 [20.2]
DTR60-075	75:1	28 [248]	20 [178]	17 [153]	50 [445]	23 [201]	16 [144]	14 [124]	0,35 [3.0]	2,3 [20.2]
DTR60-090	90:1	28 [244]	20 [175]	17 [150]	52 [460]	22 [198]	16 [142]	14 [122]	0,36 [3.1]	2,3 [20.0]
DTR60-100	100:1	27 [237]	19 [171]	16 [146]	49 [435]	22 [193]	16 [138]	13 [119]	0,41 [3.5]	2,2 [19.9]
DTR60-120	120:1	24 [210]	22 [192]	19 [164]	45 [402]	24 [210]	18 [155]	15 [133]	0,33 [3.0]	2,3 [20.2]
DTR60-125	125:1	29 [257]	23 [207]	20 [178]	51 [455]	27 [235]	19 [168]	16 [144]	0,32 [2.8]	2,4 [21.5]
DTR60-150	150:1	30 [268]	22 [193]	19 [165]	50 [445]	22 [198]	18 [156]	15 [134]	0,35 [2.9]	2,3 [20.1]
DTR60-200	200:1	31 [275]	24 [210]	20 [180]	51 [450]	27 [237]	19 [171]	16 [146]	0,41 [3.4]	2,3 [20.2]
DTR60-250	250:1	32 [279]	25 [224]	22 [193]	51 [455]	29 [254]	21 [182]	18 [156]	0,32 [2.7]	2,4 [21.5]
DTR60-300	300:1	23 [202]	20 [175]	18 [162]	49 [430]	21 [186]	18 [162]	17 [150]	0,35 [2.8]	1,7 [14.8]
DTR60-400	400:1	24 [210]	20 [181]	19 [169]	49 [430]	22 [194]	19 [168]	18 [156]	0,33 [2.7]	1,7 [14.8]
DTR60-500	500:1	24 [215]	21 [186]	20 [175]	49 [430]	23 [199]	20 [173]	18 [162]	0,30 [2.7]	1,7 [14.8]

¹ Ratios are exact, higher ratios and other custom options are also available, consult factory.
 T_r = Rated output torque at rated speed for specific hours of life.

T_{peak} = Allowable momentary peak torque for emergency stop or heavy shock loading.
 J = Mass moment of inertia reflected to the input shaft (including pinion assembly).

DuraTRUE 90™ Size 60S (Slim Line)

Right Angle Gearheads

Metric

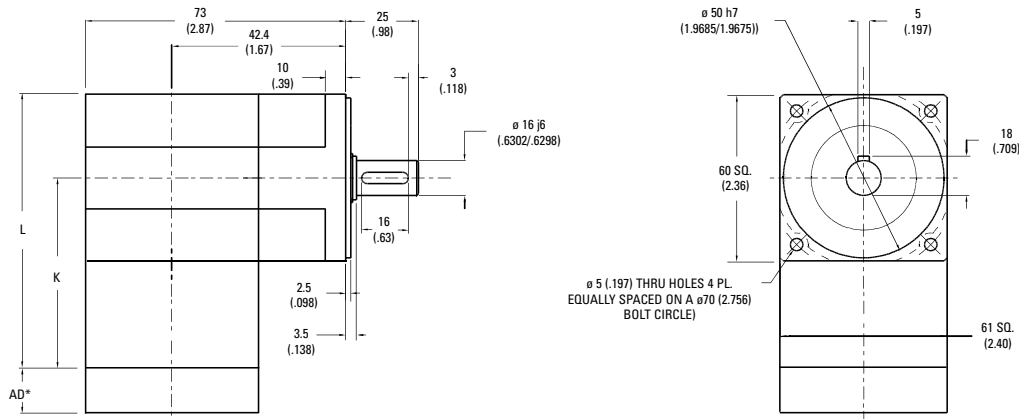

Ratio ¹	Dimension 'K' mm [in]	Dimension 'L' mm [in]	Backlash [arc-min]	Weight kg [lb]	Efficiency
1:1 to 5:1P	79 [3.11]	109,5 [4.31]	8 max	2,3 [5]	98%
5:1T to 50:1	96 [3.79]	127 [4.99]	9 max	2,5 [5.5]	93%
60:1 to 500:1	114 [4.48]	144 [5.68]	9 max	2,7 [6]	88%

All dimensions are: mm (inch)
 AD** = Adapter length
 Adapter length will vary depending on motor.
 Efficiency is calculated at 100% of the rated torque.

Performance Specifications

Part Number	Ratio ¹	10000 Hour Life			T _{peak} Nm [in-lb]	20000 Hour Life			J kg-cm ² [in-lb-sec ² ×10 ⁻⁴]	Torsional Stiffness Nm/arc-min [in-lb/arc-min]
		T _r (1000 rpm) Nm [in-lb]	T _r (3000 rpm) Nm [in-lb]	T _r (5000 rpm) Nm [in-lb]		T _r (1000 rpm) Nm [in-lb]	T _r (3000 rpm) Nm [in-lb]	T _r (5000 rpm) Nm [in-lb]		
DTR60S-001	1:1	7 [66]	7 [60]	6 [54]	25 [217]	7 [61]	6 [56]	6 [50]	0,79 [7.0]	1,8 [15.8]
DTR60S-002	2:1	16 [145]	15 [132]	14 [120]	45 [400]	15 [134]	14 [122]	12 [111]	0,41 [3.6]	2,7 [23.8]
DTR60S-003	3:1	10 [92]	10 [84]	9 [76]	34 [300]	10 [85]	9 [78]	8 [70]	0,35 [3.1]	3,0 [26.9]
DTR60S-004	4:1	8 [68]	7 [62]	6 [56]	30 [264]	7 [63]	6 [57]	6 [52]	0,32 [2.9]	3,2 [28.2]
DTR60S-005P	5:1P	6 [56]	6 [51]	5 [46]	23 [200]	6 [52]	5 [47]	5 [43]	0,32 [2.8]	3,3 [28.8]
DTR60S-005T	5:1T	23 [200]	18 [162]	16 [138]	46 [407]	21 [182]	15 [132]	13 [112]	0,42 [3.7]	3,3 [28.8]
DTR60S-006	6:1	19 [171]	16 [145]	16 [141]	46 [407]	19 [167]	15 [134]	15 [130]	0,41 [3.7]	2,1 [18.8]
DTR60S-009	9:1	12 [109]	10 [92]	10 [90]	36 [321]	12 [106]	10 [85]	9 [83]	0,35 [3.1]	2,7 [23.7]
DTR60S-010	10:1	20 [176]	18 [160]	16 [145]	46 [407]	20 [174]	17 [154]	15 [134]	0,39 [3.5]	2,1 [18.5]
DTR60S-012	12:1	9 [80]	8 [68]	7 [66]	32 [280]	9 [78]	7 [63]	7 [61]	0,33 [3.0]	3,0 [26.1]
DTR60S-015	15:1	13 [112]	12 [102]	10 [92]	37 [330]	12 [110]	11 [98]	10 [85]	0,33 [2.9]	3,1 [27.4]
DTR60S-020	20:1	9 [82]	8 [75]	8 [68]	46 [407]	9 [81]	8 [72]	7 [63]	0,31 [2.8]	2,9 [26.0]
DTR60S-025	25:1	8 [68]	7 [62]	6 [56]	25 [220]	8 [67]	7 [59]	6 [52]	0,31 [2.7]	3,1 [27.3]
DTR60S-030	30:1	13 [114]	12 [109]	12 [105]	38 [339]	13 [114]	12 [107]	11 [101]	0,32 [2.8]	2,5 [22.4]
DTR60S-040	40:1	10 [84]	9 [81]	9 [77]	33 [292]	9 [84]	9 [79]	8 [74]	0,30 [2.7]	2,8 [25.2]
DTR60S-050	50:1	8 [69]	7 [66]	7 [63]	25 [225]	8 [69]	7 [65]	7 [61]	0,30 [2.6]	3,0 [26.8]
DTR60S-060	60:1	21 [182]	20 [180]	20 [177]	46 [407]	21 [182]	20 [178]	20 [175]	0,42 [3.7]	2,0 [18.1]
DTR60S-075	75:1	13 [116]	13 [114]	13 [112]	39 [345]	13 [115]	13 [113]	12 [110]	0,33 [3.0]	2,6 [23.4]
DTR60S-090	90:1	13 [116]	13 [114]	13 [113]	39 [348]	13 [116]	13 [114]	13 [111]	0,35 [3.1]	2,6 [23.3]
DTR60S-100	100:1	21 [183]	20 [181]	20 [180]	46 [407]	21 [182]	20 [180]	20 [178]	0,40 [3.5]	2,1 [18.3]
DTR60S-120	120:1	10 [85]	10 [84]	9 [83]	34 [300]	10 [85]	9 [84]	9 [82]	0,33 [3.0]	2,9 [25.8]
DTR60S-125	125:1	8 [70]	8 [69]	8 [68]	26 [230]	8 [70]	8 [68]	8 [67]	0,31 [2.8]	3,1 [27.3]
DTR60S-150	150:1	13 [116]	13 [115]	13 [114]	40 [351]	13 [116]	13 [115]	13 [114]	0,33 [2.9]	2,6 [23.4]
DTR60S-200	200:1	21 [183]	21 [182]	21 [181]	46 [407]	21 [183]	21 [182]	20 [181]	0,39 [3.4]	1,9 [17.0]
DTR60S-250	250:1	8 [70]	8 [70]	8 [69]	26 [230]	8 [70]	8 [69]	8 [69]	0,31 [2.7]	3,1 [27.3]
DTR60S-300	300:1	13 [116]	13 [116]	13 [115]	40 [354]	13 [116]	13 [116]	13 [115]	0,32 [2.8]	2,5 [22.4]
DTR60S-400	400:1	10 [86]	10 [85]	10 [85]	34 [304]	10 [86]	10 [85]	10 [85]	0,31 [2.7]	2,8 [25.2]
DTR60S-500	500:1	8 [70]	8 [70]	8 [70]	26 [230]	8 [70]	8 [70]	8 [70]	0,30 [2.7]	3,0 [26.8]

Ratio 5P is designed using only PowerTRUE face gearing technology.

Ratio 5T adds a True Planetary gearing stage for increased torque capacity.

¹ Ratios are exact, higher ratios and other custom options are also available, consult factory.

T_r = Rated output torque at rated speed for specific hours of life.

J = Mass moment of inertia reflected to the input shaft (including pinion assembly)

T_{peak} = Allowable momentary peak torque for emergency stop or heavy shock loading.

DuraTRUE 90™ Size 90

Right Angle Gearheads

Metric

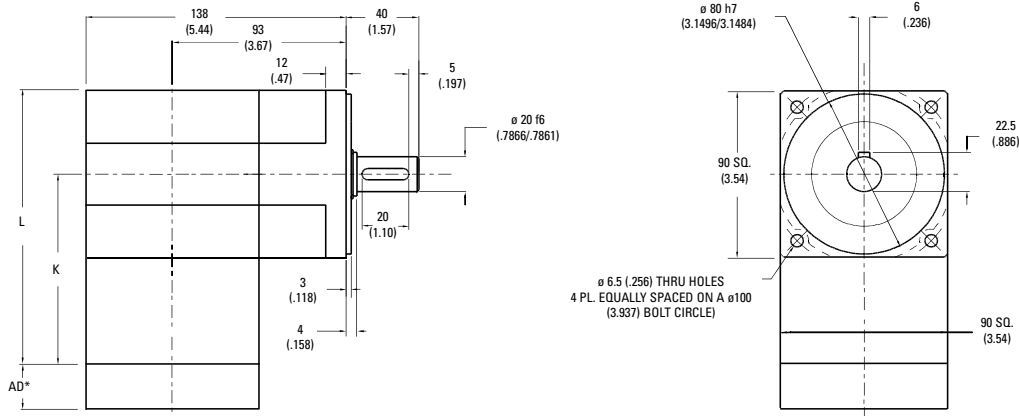

Ratio ¹	Dimension 'K' mm [in]	Dimension 'L' mm [in]	Backlash [arc-min]	Weight kg [lb]	Efficiency
5:1 to 50:1	101 [3.99]	146 [5.76]	9 max	4,8 [10]	93%
60:1 to 500:1	124 [4.89]	169 [6.66]	9 max	5,5 [12]	88%

All dimensions are: mm (inch)
 AD** = Adapter length
 Adapter length will vary depending on motor.
 Efficiency is calculated at 100% of the rated torque.

Performance Specifications

Part Number	Ratio ¹	10000 Hour Life			T _{peak} Nm [in-lb]	20000 Hour Life			J kg-cm ² [in-lb-sec ² x10 ⁻⁴]	Torsional Stiffness Nm/arc-min [in-lb/arc-min]
		T _r (1000 rpm) Nm [in-lb]	T _r (3000 rpm) Nm [in-lb]	T _r (5000 rpm) Nm [in-lb]		T _r (1000 rpm) Nm [in-lb]	T _r (3000 rpm) Nm [in-lb]	T _r (5000 rpm) Nm [in-lb]		
DTR90-005	5:1	79 [702]	58 [515]	50 [442]	167 [1479]	66 [582]	47 [418]	41 [359]	1,64 [14.5]	7,8 [69.2]
DTR90-006	6:1	82 [722]	61 [544]	53 [467]	167 [1479]	69 [614]	50 [442]	43 [379]	1,63 [14.4]	5,5 [48.2]
DTR90-009	9:1	75 [665]	69 [614]	60 [527]	167 [1479]	75 [665]	56 [499]	48 [428]	1,39 [12.3]	5,5 [48.8]
DTR90-010	10:1	79 [703]	68 [599]	58 [514]	167 [1479]	76 [676]	55 [486]	47 [417]	1,62 [14.3]	5,5 [48.4]
DTR90-012	12:1	57 [509]	57 [509]	57 [509]	144 [1272]	57 [509]	57 [509]	53 [467]	1,29 [11.4]	5,5 [49.0]
DTR90-015	15:1	82 [723]	75 [664]	66 [580]	167 [1479]	80 [707]	62 [549]	53 [471]	1,26 [11.1]	5,5 [49.0]
DTR90-020	20:1	83 [737]	77 [681]	72 [633]	167 [1479]	81 [720]	68 [599]	58 [514]	1,28 [11.3]	5,5 [48.7]
DTR90-025	25:1	71 [624]	71 [624]	71 [624]	167 [1479]	71 [624]	71 [624]	62 [549]	1,26 [11.1]	5,5 [48.7]
DTR90-030	30:1	64 [568]	55 [488]	51 [452]	167 [1479]	59 [526]	51 [452]	47 [418]	1,38 [12.2]	4,0 [35.6]
DTR90-040	40:1	67 [590]	58 [509]	53 [472]	167 [1479]	62 [546]	53 [471]	49 [437]	1,28 [11.3]	4,0 [35.6]
DTR90-050	50:1	69 [608]	59 [525]	55 [488]	167 [1479]	63 [562]	55 [486]	51 [452]	1,25 [11.1]	4,0 [35.6]
DTR90-060	60:1	106 [941]	80 [709]	69 [608]	167 [1479]	90 [800]	65 [576]	56 [494]	1,63 [14.4]	5,5 [48.6]
DTR90-075	75:1	98 [870]	90 [799]	79 [698]	167 [1479]	96 [851]	75 [661]	64 [567]	1,39 [12.3]	5,5 [48.4]
DTR90-090	90:1	98 [866]	90 [800]	78 [687]	167 [1479]	98 [866]	73 [650]	63 [558]	1,39 [12.3]	5,4 [48.0]
DTR90-100	100:1	103 [916]	88 [780]	76 [670]	167 [1479]	100 [881]	72 [633]	61 [543]	1,62 [14.3]	5,4 [47.8]
DTR90-120	120:1	75 [663]	75 [663]	75 [663]	144 [1272]	75 [663]	75 [663]	69 [608]	1,29 [11.4]	5,5 [48.5]
DTR90-125	125:1	85 [751]	85 [751]	85 [751]	167 [1479]	85 [751]	85 [751]	75 [661]	1,26 [11.1]	5,8 [51.6]
DTR90-150	150:1	106 [942]	98 [865]	85 [756]	167 [1479]	98 [866]	81 [715]	69 [614]	1,39 [12.3]	5,5 [48.3]
DTR90-200	200:1	109 [960]	100 [887]	93 [825]	167 [1479]	108 [938]	88 [780]	76 [670]	1,61 [14.2]	5,5 [48.5]
DTR90-250	250:1	92 [813]	92 [813]	92 [813]	167 [1479]	92 [813]	92 [813]	81 [715]	1,26 [11.1]	5,8 [51.5]
DTR90-300	300:1	84 [740]	72 [636]	67 [589]	167 [1479]	77 [685]	67 [589]	62 [545]	1,38 [12.2]	4,0 [35.5]
DTR90-400	400:1	87 [769]	75 [663]	69 [615]	167 [1479]	80 [711]	69 [614]	64 [569]	1,28 [11.3]	4,0 [35.5]
DTR90-500	500:1	90 [792]	77 [684]	72 [636]	167 [1479]	83 [732]	72 [633]	67 [589]	1,20 [10.6]	4,0 [35.6]

¹ Ratios are exact, higher ratios and other custom options are also available, consult factory.
 T_r = Rated output torque at rated speed for specific hours of life.

T_{peak} = Allowable momentary peak torque for emergency stop or heavy shock loading.
 J = Mass moment of inertia reflected to the input shaft (including pinion assembly).

DuraTRUE 90™ Size 90S (Slim Line)

Right Angle Gearheads

Metric

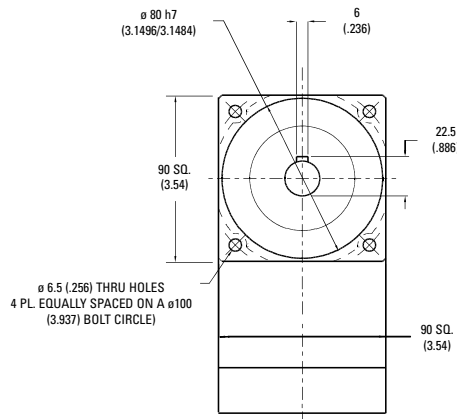
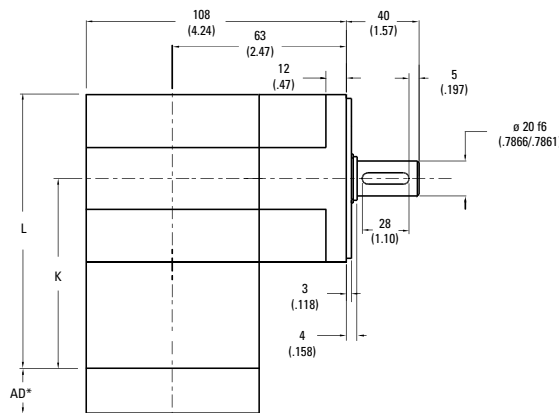

Ratio ¹	Dimension 'K' mm [in]	Dimension 'L' mm [in]	Backlash [arc-min]	Weight kg [lb]	Efficiency
1:1 to 5:1P	101 [3.99]	146 [5.76]	8 max	4,1 [9]	98%
5:1T to 50:1	124 [4.89]	169 [6.66]	9 max	4,8 [10]	93%
60:1 to 500:1	114 [5.79]	192 [7.56]	9 max	5,5 [12]	88%

All dimensions are: mm (inch)

AD** = Adapter length

Adapter length will vary depending on motor.

Efficiency is calculated at 100% of the rated torque.

Performance Specifications

Part Number	Ratio ¹	10000 Hour Life			T _{peak} Nm [in-lb]	20000 Hour Life			J kg-cm ² [in-lb-sec ² x10 ⁻⁴]	Torsional Stiffness Nm/arc-min [in-lb/arc-min]
		T _r (1000 rpm) Nm [in-lb]	T _r (3000 rpm) Nm [in-lb]	T _r (5000 rpm) Nm [in-lb]		T _r (1000 rpm) Nm [in-lb]	T _r (3000 rpm) Nm [in-lb]	T _r (5000 rpm) Nm [in-lb]		
DTR90S-001	1:1	21 [188]	19 [171]	17 [155]	62 [548]	20 [173]	18 [158]	16 [143]	3,11 [27.5]	4,3 [37.9]
DTR90S-002	2:1	48 [426]	44 [389]	40 [352]	140 [1237]	44 [394]	41 [359]	37 [325]	1,59 [14.1]	6,5 [57.2]
DTR90S-003	3:1	32 [281]	29 [256]	26 [232]	114 [1005]	29 [260]	27 [237]	24 [214]	1,37 [12.1]	7,3 [64.6]
DTR90S-004	4:1	24 [215]	22 [196]	20 [177]	87 [772]	22 [199]	20 [181]	19 [164]	1,27 [11.2]	7,6 [67.7]
DTR90S-005P	5:1P	18 [158]	16 [144]	15 [131]	73 [645]	17 [146]	15 [133]	14 [121]	1,25 [11.0]	7,8 [69.2]
DTR90S-005T	5:1T	64 [568]	55 [483]	53 [469]	140 [1237]	63 [556]	50 [446]	49 [433]	1,64 [14.5]	5,1 [45.1]
DTR90S-006	6:1	57 [501]	48 [426]	47 [414]	140 [1237]	55 [490]	44 [394]	43 [382]	1,63 [14.4]	5,1 [45.1]
DTR90S-009	9:1	37 [331]	32 [281]	31 [273]	124 [1095]	37 [323]	29 [260]	28 [252]	1,37 [12.1]	6,4 [56.9]
DTR90S-010	10:1	58 [516]	53 [471]	48 [426]	140 [1237]	58 [510]	51 [452]	44 [394]	1,54 [13.7]	5,0 [44.5]
DTR90S-012	12:1	29 [253]	24 [215]	24 [209]	94 [836]	28 [247]	22 [199]	22 [193]	1,31 [11.6]	7,1 [62.7]
DTR90S-015	15:1	38 [340]	35 [311]	32 [281]	128 [1131]	38 [336]	34 [298]	29 [260]	1,28 [11.3]	7,4 [65.8]
DTR90S-020	20:1	29 [261]	27 [238]	24 [215]	140 [1237]	29 [257]	26 [228]	22 [199]	1,22 [10.8]	7,1 [62.4]
DTR90S-025	25:1	22 [192]	20 [175]	18 [158]	80 [705]	21 [189]	19 [168]	17 [146]	1,20 [10.6]	7,4 [65.6]
DTR90S-030	30:1	39 [348]	38 [333]	36 [318]	131 [1161]	39 [346]	37 [327]	35 [307]	1,25 [11.1]	6,1 [53.8]
DTR90S-040	40:1	30 [266]	29 [255]	28 [243]	99 [880]	30 [265]	28 [250]	27 [235]	1,19 [10.6]	6,8 [60.5]
DTR90S-050	50:1	22 [196]	21 [188]	20 [179]	82 [725]	22 [195]	21 [184]	20 [173]	1,17 [10.4]	7,3 [64.2]
DTR90S-060	60:1	60 [535]	60 [527]	59 [520]	140 [1237]	60 [534]	59 [524]	58 [514]	1,63 [14.4]	4,9 [43.5]
DTR90S-075	75:1	40 [352]	39 [346]	38 [340]	136 [1200]	40 [351]	39 [344]	38 [336]	1,31 [11.6]	6,4 [56.2]
DTR90S-090	90:1	40 [353]	39 [348]	39 [343]	136 [1206]	40 [352]	39 [346]	38 [339]	1,37 [12.1]	6,3 [55.8]
DTR90S-100	100:1	61 [536]	60 [532]	60 [527]	140 [1237]	61 [536]	60 [530]	59 [524]	1,55 [13.7]	5,0 [43.9]
DTR90S-120	120:1	31 [270]	30 [266]	30 [262]	103 [908]	30 [269]	30 [265]	29 [260]	1,31 [11.6]	7,0 [62.0]
DTR90S-125	125:1	22 [198]	22 [195]	22 [192]	84 [740]	22 [198]	22 [194]	21 [189]	1,23 [10.8]	7,4 [65.5]
DTR90S-150	150:1	40 [354]	40 [351]	39 [348]	138 [1218]	40 [353]	39 [350]	39 [346]	1,29 [11.4]	6,3 [56.1]
DTR90S-200	200:1	61 [538]	60 [535]	60 [533]	140 [1237]	61 [537]	60 [534]	60 [531]	1,52 [13.5]	4,6 [40.7]
DTR90S-250	250:1	23 [199]	22 [198]	22 [196]	85 [750]	22 [199]	22 [197]	22 [195]	1,21 [10.7]	7,4 [65.4]
DTR90S-300	300:1	40 [355]	40 [353]	40 [352]	139 [1230]	40 [354]	40 [352]	40 [350]	1,26 [11.1]	6,1 [53.7]
DTR90S-400	400:1	31 [271]	31 [270]	30 [269]	104 [924]	31 [271]	30 [270]	30 [268]	1,20 [10.6]	6,8 [60.5]
DTR90S-500	500:1	23 [200]	22 [199]	22 [198]	85 [755]	23 [200]	22 [198]	22 [197]	1,18 [10.4]	7,3 [64.2]

Ratio 5P is designed using only PowerTRUE face gearing technology.

Ratio 5T adds a True Planetary gearing stage for increased torque capacity.

¹ Ratios are exact, higher ratios and other custom options are also available, consult factory.

T_r = Rated output torque at rated speed for specific hours of life.

J = Mass moment of inertia reflected to the input shaft (including pinion assembly)

T_{peak} = Allowable momentary peak torque for emergency stop or heavy shock loading.

DuraTRUE 90™ Size 115

Right Angle Gearheads

Metric

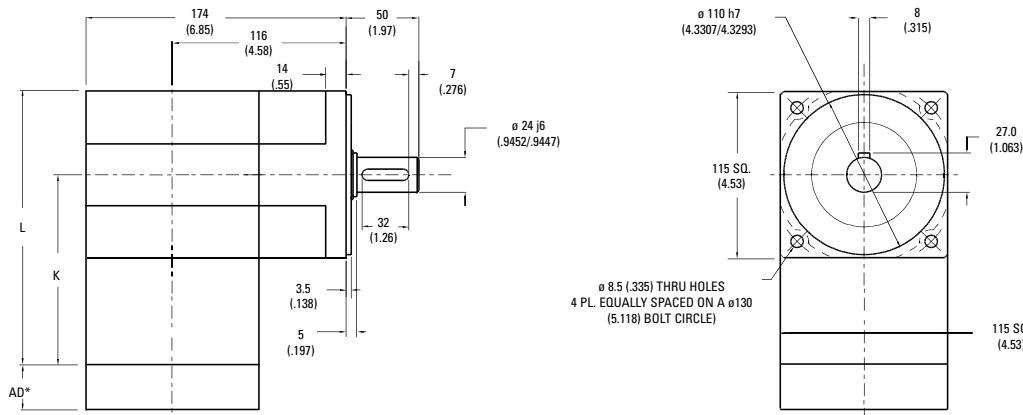

Ratio ¹	Dimension 'K' mm [in]	Dimension 'L' mm [in]	Backlash [arc-min]	Weight kg [lb]	Efficiency
5:1 to 50:1	137 [5.40]	195 [7.67]	8 max	11 [24]	93%
60:1 to 500:1	168,4 [6.63]	226 [8.90]	9 max	12 [27]	88%

All dimensions are: mm (inch)

AD** = Adapter length

Adapter length will vary depending on motor. Efficiency is calculated at 100% of the rated torque.

Performance Specifications

Part Number	Ratio ¹	10000 Hour Life			T _{peak} Nm [in-lb]	20000 Hour Life			J kg-cm ² [in-lb-sec ² x10 ⁻⁴]	Torsional Stiffness Nm/arc-min [in-lb/arc-min]
		T _r (1000 rpm) Nm [in-lb]	T _r (3000 rpm) Nm [in-lb]	T _r (5000 rpm) Nm [in-lb]		T _r (1000 rpm) Nm [in-lb]	T _r (3000 rpm) Nm [in-lb]	T _r (5000 rpm) Nm [in-lb]		
DTR115-005	5:1	123 [1086]	88 [781]	76 [670]	284 [2511]	100 [882]	72 [634]	61 [544]	2,79 [24.7]	15,3 [135]
DTR115-006	6:1	130 [1147]	93 [825]	80 [708]	284 [2511]	105 [932]	76 [670]	65 [575]	2,77 [24.5]	12,5 [110]
DTR115-009	9:1	146 [1295]	105 [932]	90 [799]	284 [2511]	119 [1052]	86 [757]	73 [649]	2,37 [21.0]	12,6 [112]
DTR115-010	10:1	143 [1262]	103 [908]	88 [779]	284 [2511]	116 [1025]	83 [738]	72 [633]	2,75 [24.3]	13,1 [116]
DTR115-012	12:1	137 [1210]	115 [1016]	98 [871]	284 [2511]	130 [1147]	93 [825]	80 [708]	2,19 [19.4]	12,7 [112]
DTR115-015	15:1	161 [1425]	116 [1025]	99 [880]	284 [2511]	131 [1158]	94 [833]	81 [715]	2,14 [18.9]	12,7 [112]
DTR115-020	20:1	164 [1453]	126 [1118]	108 [959]	284 [2511]	143 [1262]	103 [908]	88 [779]	2,18 [19.3]	13,2 [117]
DTR115-025	25:1	167 [1474]	135 [1195]	116 [1025]	284 [2511]	153 [1350]	110 [971]	94 [833]	2,14 [18.9]	13,2 [117]
DTR115-030	30:1	105 [930]	90 [796]	83 [736]	284 [2511]	97 [861]	83 [737]	77 [681]	2,34 [20.7]	11,5 [102]
DTR115-040	40:1	109 [967]	94 [831]	87 [770]	284 [2511]	101 [894]	87 [769]	80 [712]	2,17 [19.2]	11,5 [102]
DTR115-050	50:1	112 [995]	97 [858]	90 [796]	284 [2511]	104 [921]	90 [794]	83 [737]	2,13 [18.8]	11,5 [102]
DTR115-060	60:1	169 [1495]	121 [1075]	104 [923]	284 [2511]	137 [1214]	99 [873]	85 [749]	2,77 [24.5]	13,2 [117]
DTR115-075	75:1	194 [1715]	139 [1233]	120 [1059]	284 [2511]	139 [1233]	113 [1002]	97 [860]	2,35 [20.8]	13,1 [116]
DTR115-090	90:1	191 [1687]	137 [1214]	118 [1041]	284 [2511]	155 [1371]	111 [986]	96 [846]	2,37 [21.0]	12,5 [110]
DTR115-100	100:1	186 [1644]	134 [1183]	115 [1015]	284 [2511]	151 [1336]	109 [962]	93 [825]	2,75 [24.3]	13,0 [115]
DTR115-120	120:1	178 [1577]	150 [1324]	128 [1135]	284 [2511]	169 [1495]	121 [1075]	104 [923]	2,19 [19.4]	12,6 [111]
DTR115-125	125:1	200 [1774]	162 [1438]	139 [1233]	284 [2511]	184 [1624]	132 [1168]	113 [1002]	2,14 [18.9]	13,2 [117]
DTR115-150	150:1	210 [1857]	151 [1336]	130 [1147]	284 [2511]	170 [1509]	123 [1085]	105 [932]	2,35 [20.8]	13,1 [116]
DTR115-200	200:1	214 [1893]	165 [1457]	141 [1250]	284 [2511]	186 [1644]	134 [1183]	115 [1015]	2,73 [24.2]	13,2 [116]
DTR115-250	250:1	217 [1921]	176 [1557]	151 [1336]	284 [2511]	199 [1759]	143 [1265]	123 [1085]	2,14 [18.9]	13,2 [117]
DTR115-300	300:1	137 [1212]	117 [1037]	108 [959]	284 [2511]	127 [1122]	109 [960]	100 [887]	2,34 [20.7]	11,5 [102]
DTR115-400	400:1	142 [1260]	122 [1083]	113 [1003]	284 [2511]	132 [1165]	113 [1002]	105 [928]	2,17 [19.2]	11,5 [102]
DTR115-500	500:1	146 [1296]	126 [1118]	117 [1037]	284 [2511]	136 [1200]	117 [1035]	109 [960]	2,03 [18.0]	11,5 [102]

¹ Ratios are exact, higher ratios and other custom options are also available, consult factory.

T_r = Rated output torque at rated speed for specific hours of life.

T_{peak} = Allowable momentary peak torque for emergency stop or heavy shock loading.
J = Mass moment of inertia reflected to the input shaft (including pinion assembly).

DuraTRUE 90™ Size 115S (Slim Line)

Right Angle Gearheads

Metric

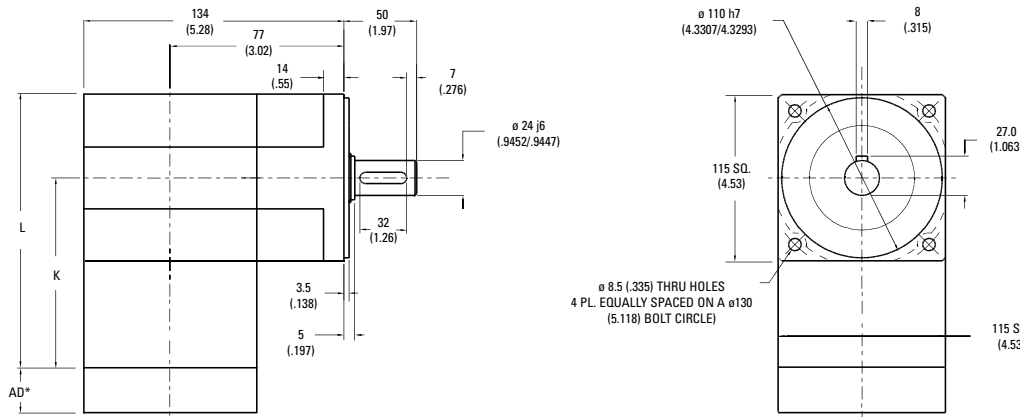

Ratio ¹	Dimension 'K' mm [in]	Dimension 'L' mm [in]	Backlash [arc-min]	Weight kg [lb]	Efficiency
1:1 to 5:1P	137 [5.40]	195 [7.67]	8 max	9 [20]	98%
5:1T to 50:1	168,4 [6.63]	226 [8.90]	9 max	11 [24]	93%
60:1 to 500:1	200 [7.87]	257 [10.13]	9 max	12 [27]	88%

All dimensions are: mm (inch)
AD** = Adapter length
Adapter length will vary depending on motor. Efficiency is calculated at 100% of the rated torque.

Performance Specifications

Part Number	Ratio ¹	10000 Hour Life			T _{peak} Nm [in-lb]	20000 Hour Life			J kg-cm ² [in-lb-sec ² ×10 ⁻⁴]	Torsional Stiffness Nm/arc-min [in-lb/arc-min]
		T _r (1000 rpm) Nm [in-lb]	T _r (3000 rpm) Nm [in-lb]	T _r (5000 rpm) Nm [in-lb]		T _r (1000 rpm) Nm [in-lb]	T _r (3000 rpm) Nm [in-lb]	T _r (5000 rpm) Nm [in-lb]		
DTR115S-001	1:1	63 [554]	57 [506]	52 [457]	203 [1800]	58 [512]	53 [467]	48 [422]	5,28 [46.7]	7,6 [67.6]
DTR115S-002	2:1	112 [989]	102 [903]	92 [816]	283 [2505]	103 [913]	94 [834]	85 [754]	2,71 [23.9]	12,5 [111]
DTR115S-003	3:1	87 [768]	79 [701]	72 [634]	256 [2265]	80 [709]	73 [647]	66 [585]	2,33 [20.6]	14,2 [126]
DTR115S-004	4:1	58 [511]	53 [467]	48 [422]	199 [1760]	53 [472]	49 [431]	44 [390]	2,16 [19.1]	14,9 [132]
DTR115S-005P	5:1P	43 [384]	40 [350]	36 [316]	164 [1450]	40 [354]	37 [323]	33 [292]	2,12 [18.8]	15,3 [135]
DTR115S-005T	5:1T	170 [1505]	126 [1117]	108 [958]	283 [2505]	143 [1262]	102 [907]	88 [778]	2,78 [24.6]	15,3 [135]
DTR115S-006	6:1	131 [1163]	112 [989]	109 [960]	283 [2505]	129 [1138]	103 [913]	100 [887]	2,77 [24.5]	10,2 [90.7]
DTR115S-009	9:1	102 [903]	87 [768]	84 [746]	281 [2490]	100 [884]	80 [709]	78 [689]	2,32 [20.5]	12,8 [113]
DTR115S-010	10:1	135 [1198]	124 [1094]	112 [989]	283 [2505]	134 [1183]	118 [1048]	103 [913]	2,63 [23.2]	10,2 [90.3]
DTR115S-012	12:1	68 [601]	58 [511]	56 [496]	217 [1920]	66 [588]	53 [472]	52 [458]	2,22 [19.6]	14,0 [124]
DTR115S-015	15:1	105 [930]	96 [849]	87 [768]	283 [2505]	104 [919]	92 [814]	80 [709]	2,18 [19.3]	14,6 [130]
DTR115S-020	20:1	70 [619]	64 [565]	58 [511]	283 [2505]	69 [612]	61 [542]	53 [472]	2,08 [18.4]	14,0 [124]
DTR115S-025	25:1	52 [465]	48 [424]	43 [384]	183 [1620]	52 [459]	46 [406]	40 [354]	2,04 [18.0]	14,6 [129]
DTR115S-030	30:1	107 [951]	103 [910]	98 [869]	283 [2505]	107 [945]	101 [892]	95 [840]	2,13 [18.9]	12,5 [111]
DTR115S-040	40:1	72 [633]	68 [606]	65 [579]	231 [2040]	71 [629]	67 [594]	63 [559]	2,03 [18.0]	13,8 [122]
DTR115S-050	50:1	54 [475]	51 [454]	49 [434]	188 [1665]	53 [472]	50 [446]	47 [419]	1,99 [17.6]	14,5 [128]
DTR115S-060	60:1	140 [1242]	138 [1224]	136 [1207]	283 [2505]	140 [1239]	137 [1217]	135 [1194]	2,78 [24.6]	10,0 [88.5]
DTR115S-075	75:1	109 [963]	107 [947]	105 [930]	283 [2505]	109 [960]	106 [939]	104 [919]	2,22 [19.7]	12,7 [112]
DTR115S-090	90:1	109 [964]	107 [951]	106 [937]	283 [2505]	109 [962]	107 [945]	105 [927]	2,33 [20.6]	12,6 [112]
DTR115S-100	100:1	141 [1245]	140 [1235]	138 [1224]	283 [2505]	141 [1244]	139 [1230]	137 [1217]	2,64 [23.3]	10,1 [89.5]
DTR115S-120	120:1	73 [642]	72 [633]	70 [624]	238 [2108]	72 [641]	71 [629]	70 [617]	2,23 [19.7]	13,9 [123]
DTR115S-125	125:1	54 [481]	53 [473]	52 [465]	193 [1710]	54 [480]	53 [469]	52 [459]	2,08 [18.4]	14,6 [129]
DTR115S-150	150:1	109 [967]	108 [959]	107 [951]	283 [2505]	109 [966]	108 [955]	107 [945]	2,19 [19.4]	12,7 [112]
DTR115S-200	200:1	141 [1248]	140 [1243]	140 [1237]	283 [2505]	141 [1247]	140 [1240]	139 [1234]	2,59 [22.9]	9,8 [87.1]
DTR115S-250	250:1	55 [483]	54 [479]	54 [475]	196 [1735]	54 [482]	54 [477]	53 [472]	2,05 [18.1]	14,6 [129]
DTR115S-300	300:1	109 [969]	109 [965]	109 [961]	283 [2505]	109 [968]	109 [963]	108 [958]	2,14 [18.9]	12,5 [111]
DTR115S-400	400:1	73 [645]	73 [642]	72 [640]	244 [2160]	73 [645]	72 [641]	72 [638]	2,04 [18.1]	13,8 [122]
DTR115S-500	500:1	55 [484]	54 [482]	54 [480]	198 [1755]	55 [483]	54 [481]	54 [478]	2,00 [17.7]	14,5 [128]

Ratio 5P is designed using only PowerTRUE face gearing technology.

Ratio 5T adds a True Planetary gearing stage for increased torque capacity.

¹ Ratios are exact, higher ratios and other custom options are also available, consult factory.

T_r = Rated output torque at rated speed for specific hours of life.

J = Mass moment of inertia reflected to the input shaft (including pinion assembly)

T_{peak} = Allowable momentary peak torque for emergency stop or heavy shock loading.

DuraTRUE 90™ Size 142

Right Angle Gearheads

Metric

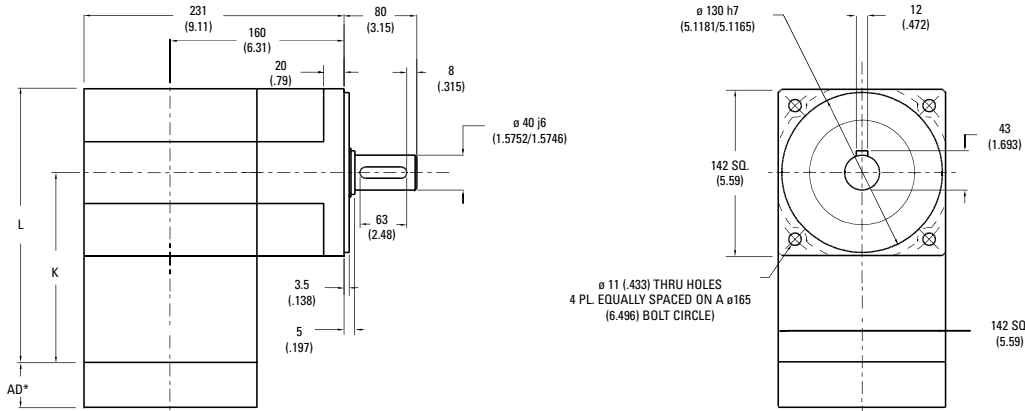

Ratio ¹	Dimension 'K' mm [in]	Dimension 'L' mm [in]	Backlash [arc-min]	Weight kg [lb]	Efficiency
5:1 to 50:1	160 [6.29]	231 [9.09]	9 max	24 [53]	93%
60:1 to 500:1	209 [8.23]	280 [11.03]	9 max	28 [62]	88%

All dimensions are: mm (inch)
AD** = Adapter length

Adapter length will vary depending on motor. Efficiency is calculated at 100% of the rated torque.

Performance Specifications

Part Number	Ratio ¹	10000 Hour Life			T _{peak} Nm [in-lb]	20000 Hour Life			J kg-cm ² [in-lb-sec ² x10 ⁻⁴]	Torsional Stiffness Nm/arc-min [in-lb/arc-min]
		T _r (1000 rpm) Nm [in-lb]	T _r (3000 rpm) Nm [in-lb]	T _r (5000 rpm) Nm [in-lb]		T _r (1000 rpm) Nm [in-lb]	T _r (3000 rpm) Nm [in-lb]	T _r (5000 rpm) Nm [in-lb]		
DTR142-005	5:1	433 [3833]	311 [2757]	267 [2365]	833 [7377]	352 [3114]	253 [2239]	217 [1921]	13,9 [123]	47,4 [419]
DTR142-006	6:1	454 [4020]	329 [2912]	282 [2498]	833 [7377]	372 [3289]	267 [2365]	229 [2029]	13,8 [122]	38,6 [342]
DTR142-009	9:1	444 [3934]	372 [3289]	319 [2821]	833 [7377]	420 [3714]	302 [2671]	259 [2292]	11,8 [104]	39,1 [346]
DTR142-010	10:1	448 [3965]	363 [3210]	311 [2754]	833 [7377]	410 [3625]	295 [2607]	253 [2237]	13,7 [121]	40,6 [360]
DTR142-012	12:1	319 [2825]	319 [2825]	319 [2825]	798 [7062]	319 [2825]	319 [2825]	282 [2498]	10,9 [96.3]	39,3 [348]
DTR142-015	15:1	463 [4096]	410 [3625]	351 [3110]	833 [7377]	453 [4005]	333 [2944]	285 [2526]	10,7 [94.2]	39,4 [349]
DTR142-020	20:1	473 [4183]	432 [3824]	383 [3390]	833 [7377]	462 [4090]	363 [3210]	311 [2754]	10,8 [95.9]	40,9 [362]
DTR142-025	25:1	399 [3532]	399 [3532]	399 [3532]	833 [7377]	399 [3532]	388 [3432]	333 [2944]	10,6 [94.0]	40,9 [362]
DTR142-030	30:1	268 [2373]	228 [2022]	134 [1185]	833 [7377]	248 [2196]	211 [1871]	195 [1724]	11,7 [103]	35,6 [315]
DTR142-040	40:1	279 [2468]	240 [2122]	221 [1952]	833 [7377]	258 [2284]	221 [1955]	204 [1807]	10,8 [95.5]	35,6 [315]
DTR142-050	50:1	287 [2543]	247 [2183]	228 [2022]	833 [7377]	266 [2353]	228 [2020]	211 [1871]	10,6 [93.7]	35,6 [315]
DTR142-060	60:1	592 [5238]	429 [3794]	368 [3255]	833 [7377]	486 [4297]	348 [3082]	299 [2644]	13,8 [122]	40,8 [361]
DTR142-075	75:1	557 [4928]	493 [4362]	423 [3742]	833 [7377]	544 [4819]	400 [3542]	343 [3039]	11,7 [104]	40,6 [360]
DTR142-090	90:1	579 [5126]	484 [4286]	415 [3676]	833 [7377]	547 [4839]	393 [3480]	337 [2986]	11,8 [104]	38,6 [342]
DTR142-100	100:1	584 [5166]	473 [4183]	405 [3588]	833 [7377]	534 [4723]	384 [3397]	329 [2915]	13,7 [121]	40,2 [356]
DTR142-120	120:1	416 [3681]	416 [3681]	416 [3681]	798 [7062]	416 [3681]	416 [3681]	368 [3255]	10,9 [96.3]	39,0 [345]
DTR142-125	125:1	480 [4250]	480 [4250]	480 [4250]	833 [7377]	480 [4250]	467 [4129]	400 [3542]	10,6 [94.0]	40,9 [362]
DTR142-150	150:1	603 [5337]	534 [4723]	458 [4052]	833 [7377]	590 [5218]	433 [3836]	372 [3291]	11,7 [104]	40,6 [360]
DTR142-200	200:1	616 [5450]	563 [4983]	499 [4417]	833 [7377]	602 [5329]	473 [4183]	405 [3588]	13,6 [120]	40,8 [361]
DTR142-250	250:1	520 [4602]	520 [4602]	520 [4602]	833 [7377]	520 [4602]	505 [4472]	433 [3836]	10,6 [94.0]	40,9 [362]
DTR142-300	300:1	349 [3092]	298 [2635]	174 [1544]	833 [7377]	323 [2861]	275 [2438]	254 [2246]	11,7 [103]	35,6 [315]
DTR142-400	400:1	363 [3216]	312 [2765]	287 [2543]	833 [7377]	336 [2976]	288 [2547]	266 [2355]	10,8 [95.5]	35,6 [315]
DTR142-500	500:1	374 [3314]	321 [2844]	298 [2635]	833 [7377]	346 [3066]	297 [2632]	275 [2438]	10,1 [89.4]	35,6 [315]

¹ Ratios are exact, higher ratios and other custom options are also available, consult factory.
T_r = Rated output torque at rated speed for specific hours of life.

T_{peak} = Allowable momentary peak torque for emergency stop or heavy shock loading
J = Mass moment of inertia reflected to the input shaft (including pinion assembly).

DuraTRUE 90™ Size 142S (Slim Line)

Right Angle Gearheads

Metric

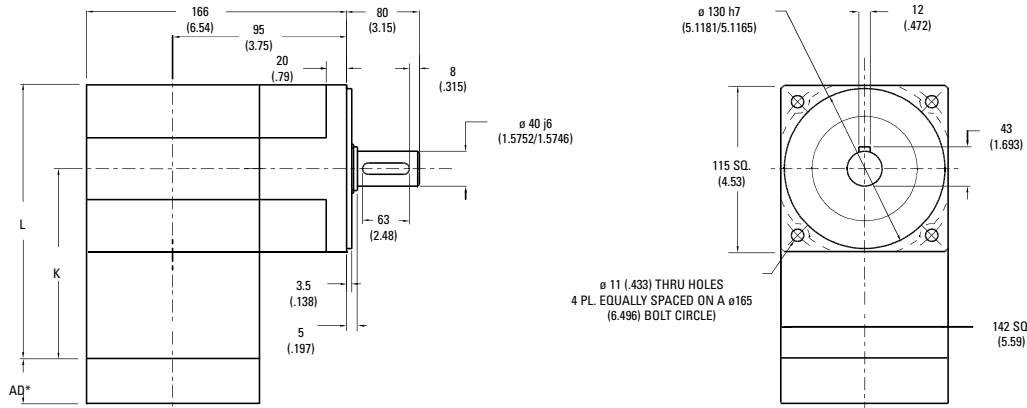

Ratio ¹	Dimension 'K' mm [in.]	Dimension 'L' mm [in.]	Backlash [arc-min]	Weight kg [lb]	Efficiency
1:1 to 5:1P	160 [6.29]	231 [9.09]	8 max	19 [43]	98%
5:1T to 50:1	209 [8.23]	280 [11.03]	9 max	24 [53]	93%
60:1 to 500:1	259 [10.18]	329 [12.97]	9 max	28 [62]	88%

All dimensions are: mm (inch)
 AD** = Adapter length
 Adapter length will vary depending on motor.
 Efficiency is calculated at 100% of the rated torque.

Performance Specifications

Part Number	Ratio ¹	10000 Hour Life			T _{peak} Nm [in-lb]	20000 Hour Life			J kg-cm ² [in-lb-sec ² x10 ⁻⁴]	Torsional Stiffness Nm/arc-min [in-lb/arc-min]
		T _r (1000 rpm) Nm [in-lb]	T _r (3000 rpm) Nm [in-lb]	T _r (5000 rpm) Nm [in-lb]		T _r (1000 rpm) Nm [in-lb]	T _r (3000 rpm) Nm [in-lb]	T _r (5000 rpm) Nm [in-lb]		
DTR142S-001	1:1	135 [1194]	123 [1090]	111 [985]	333 [2950]	125 [1103]	114 [1006]	103 [910]	26,3 [232]	23,7 [210]
DTR142S-002	2:1	279 [2474]	255 [2257]	231 [2041]	621 [5500]	258 [2284]	236 [2084]	213 [1885]	13,5 [119]	38,9 [344]
DTR142S-003	3:1	188 [1663]	171 [1518]	155 [1372]	478 [4230]	174 [1536]	158 [1401]	143 [1267]	11,6 [102]	44,1 [390]
DTR142S-004	4:1	135 [1194]	123 [1090]	111 [985]	414 [3660]	125 [1103]	114 [1006]	103 [910]	10,8 [95.1]	46,3 [410]
DTR142S-005P	5:1P	101 [896]	92 [818]	84 [739]	347 [3075]	93 [827]	85 [755]	77 [683]	10,6 [93.3]	47,4 [419]
DTR142S-005T	5:1T	340 [3009]	289 [2559]	281 [2484]	782 [6917]	333 [2944]	267 [2363]	259 [2294]	13,8 [122]	47,4 [419]
DTR142S-006	6:1	329 [2909]	279 [2474]	271 [2402]	678 [6000]	322 [2846]	258 [2284]	251 [2218]	13,8 [122]	31,8 [281]
DTR142S-009	9:1	221 [1956]	188 [1663]	182 [1614]	532 [4710]	216 [1913]	174 [1536]	168 [1491]	11,6 [102]	39,6 [351]
DTR142S-010	10:1	339 [2996]	309 [2735]	279 [2474]	734 [6500]	334 [2958]	296 [2621]	258 [2284]	13,1 [116]	31,6 [280]
DTR142S-012	12:1	159 [1404]	135 [1194]	131 [1159]	454 [4020]	155 [1374]	125 [1103]	121 [1071]	11,1 [97.7]	43,4 [384]
DTR142S-015	15:1	228 [2014]	208 [1839]	188 [1663]	551 [4875]	225 [1989]	199 [1762]	174 [1536]	10,9 [95.9]	45,4 [402]
DTR142S-020	20:1	163 [1446]	149 [1320]	135 [1194]	768 [6800]	161 [1428]	143 [1265]	125 [1103]	10,4 [91.5]	43,3 [383]
DTR142S-025	25:1	123 [1085]	112 [991]	101 [896]	391 [3460]	121 [1071]	107 [949]	93 [827]	10,2 [89.8]	45,3 [401]
DTR142S-030	30:1	233 [2058]	223 [1970]	213 [1882]	573 [5070]	231 [2045]	218 [1932]	205 [1819]	10,6 [93.8]	38,8 [343]
DTR142S-040	40:1	167 [1478]	160 [1415]	153 [1352]	486 [4300]	166 [1469]	157 [1387]	148 [1306]	10,1 [89.4]	42,8 [379]
DTR142S-050	50:1	125 [1109]	120 [1061]	115 [1014]	404 [3575]	125 [1102]	118 [1041]	111 [980]	9,9 [87.6]	45,0 [398]
DTR142S-060	60:1	351 [3105]	346 [3061]	341 [3018]	814 [7200]	350 [3099]	344 [3042]	337 [2986]	13,8 [122]	31,0 [274]
DTR142S-075	75:1	236 [2084]	232 [2049]	228 [2014]	593 [5250]	235 [2079]	230 [2034]	225 [1989]	11,1 [97.9]	39,4 [348]
DTR142S-090	90:1	236 [2087]	233 [2058]	229 [2029]	597 [5280]	235 [2083]	231 [2045]	227 [2008]	11,6 [103]	39,1 [346]
DTR142S-100	100:1	352 [3114]	349 [3088]	346 [3061]	825 [7300]	351 [3110]	348 [3076]	344 [3042]	13,1 [116]	31,3 [278]
DTR142S-120	120:1	169 [1499]	167 [1478]	165 [1457]	506 [4480]	169 [1496]	166 [1469]	163 [1442]	11,1 [98.2]	43,0 [380]
DTR142S-125	125:1	127 [1123]	125 [1104]	123 [1085]	415 [3675]	127 [1120]	124 [1096]	121 [1071]	10,4 [91.7]	45,3 [401]
DTR142S-150	150:1	237 [2093]	235 [2076]	233 [2058]	607 [5370]	236 [2091]	234 [2068]	231 [2045]	10,9 [96.4]	39,3 [348]
DTR142S-200	200:1	353 [3120]	351 [3107]	350 [3094]	842 [7450]	352 [3118]	350 [3101]	349 [3085]	12,9 [114]	30,5 [270]
DTR142S-250	250:1	127 [1128]	126 [1118]	125 [1109]	421 [3725]	127 [1126]	126 [1114]	125 [1102]	10,2 [90.3]	45,2 [400]
DTR142S-300	300:1	237 [2098]	236 [2089]	235 [2080]	614 [5430]	237 [2096]	236 [2085]	234 [2074]	10,7 [94.3]	38,8 [343]
DTR142S-400	400:1	170 [1506]	169 [1500]	169 [1494]	518 [4580]	170 [1505]	169 [1497]	168 [1489]	10,2 [89.8]	42,8 [379]
DTR142S-500	500:1	128 [1130]	127 [1125]	127 [1121]	427 [3775]	128 [1129]	127 [1123]	126 [1117]	9,96 [88.1]	45,0 [398]

Ratio 5P is designed using only PowerTRUE face gearing technology.

Ratio 5T adds a True Planetary gearing stage for increased torque capacity.

¹ Ratios are exact, higher ratios and other custom options are also available, consult factory.

T_r = Rated output torque at rated speed for specific hours of life.

J = Mass moment of inertia reflected to the input shaft (including pinion assembly)

T_{peak} = Allowable momentary peak torque for emergency stop or heavy shock loading.

Radial and Axial Load Ratings

DTR60

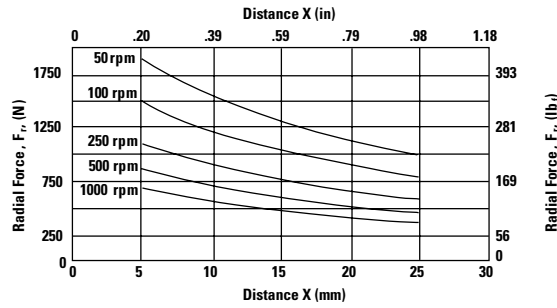
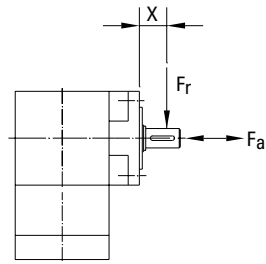

Speed rpm	Axial Load, F_a N [lb _f]
50	3075 [692]
100	2441 [549]
250	1798 [405]
500	1427 [321]
1000	1133 [255]

DTR90

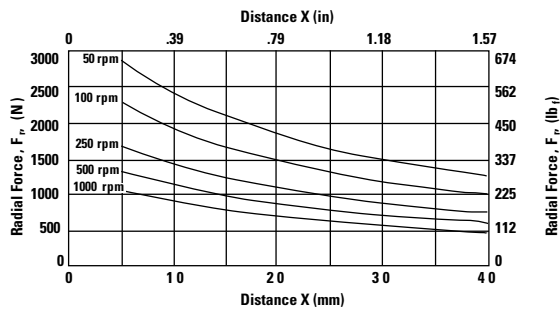
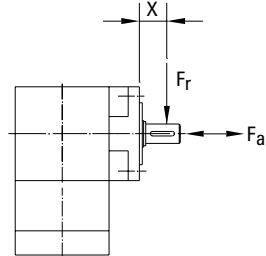

Speed rpm	Axial Load, F_a N [lb _f]
50	4506 [1014]
100	3576 [805]
250	2635 [593]
500	2091 [471]
1000	1660 [373]

DTR115

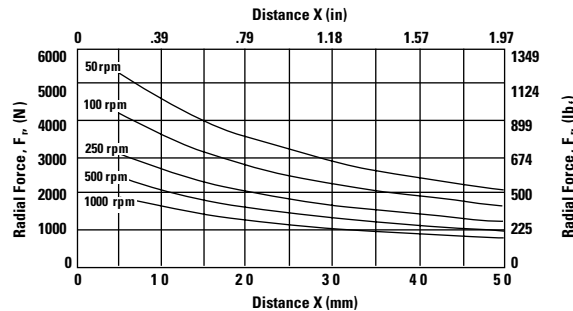
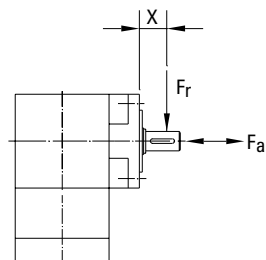

Speed rpm	Axial Load, F_a N [lb _f]
50	8196 [1844]
100	6505 [1464]
250	4793 [1078]
500	3804 [856]
1000	3019 [679]

DTR142

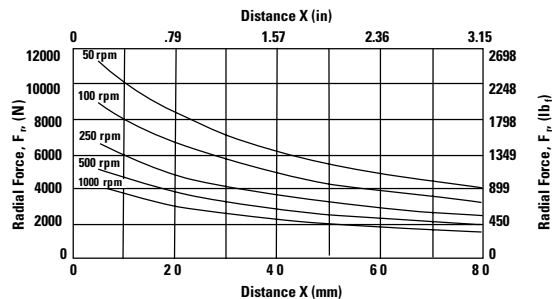
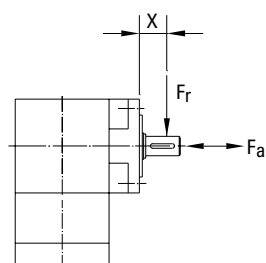

Speed rpm	Axial Load, F_a N [lb _f]
50	17023 [3830]
100	13511 [3040]
250	9956 [2240]
500	7902 [1778]
1000	6271 [1411]

These graphs display the allowable radial load at a given distance (X) from the mounting surface based on an L_{10} life of 10,000 hours for the mean output speed n_{mout} , as described on page 10,

Radial and Axial Load Ratings

DTR60S

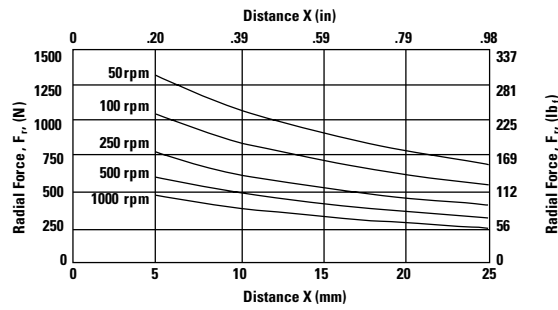
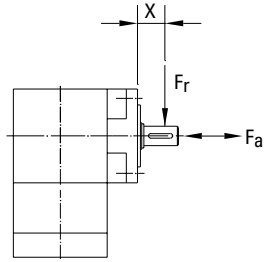

Speed rpm	Axial Load, F_a N [lb _f]
50	2155 [484]
100	1710 [384]
250	1260 [283]
500	1000 [225]
1000	794 [178]

DTR90S

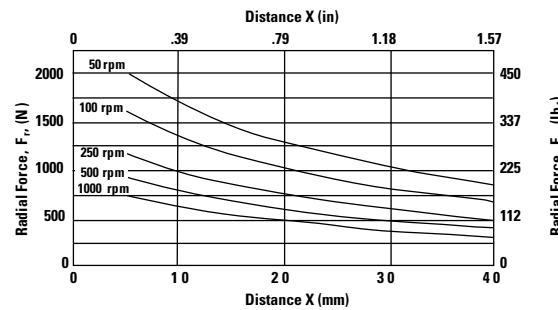
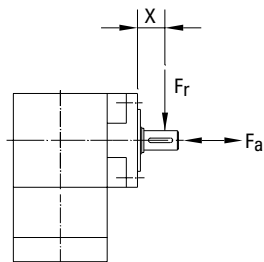

Speed rpm	Axial Load, F_a N [lb _f]
50	3157 [710]
100	2506 [563]
250	1846 [415]
500	1465 [329]
1000	1163 [261]

DTR115S

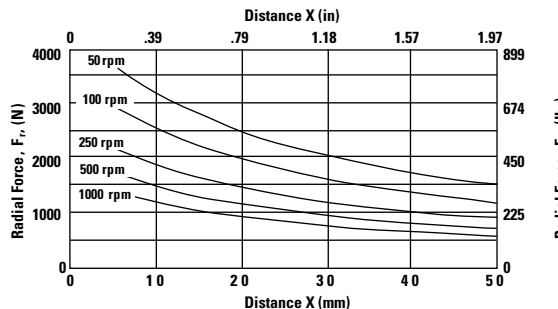
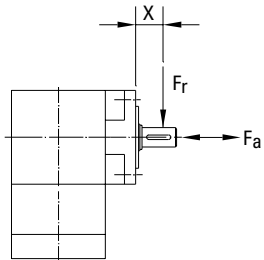

Speed rpm	Axial Load, F_a N [lb _f]
50	5742 [1291]
100	4558 [1025]
250	3358 [755]
500	2665 [599]
1000	2115 [476]

DTR142S

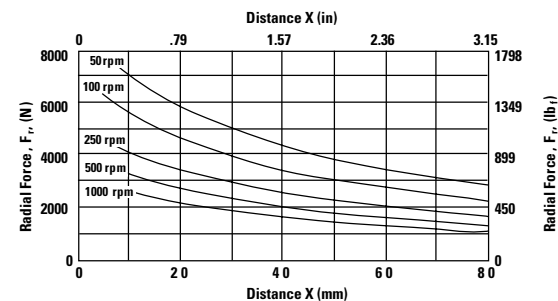
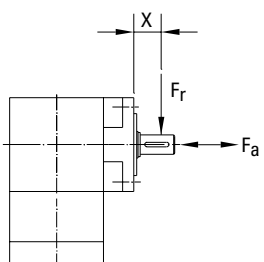

Speed rpm	Axial Load, F_a N [lb _f]
50	11925 [2681]
100	9465 [2128]
250	6974 [1568]
500	5535 [1244]
1000	4393 [988]

These graphs display the allowable radial load at a given distance (X) from the mounting surface based on an L_{10} life of 10,000 hours for the mean output speed n_{mout} , as described on page 10,



DuraTRUE 90™ Hollow Shaft

Right Angle Gearheads

Ready for Immediate Delivery	
Precision	8 arc-minutes
Frame Sizes	90mm, 115mm and 142mm
Torque Capacity	up to 865 Nm
Ratio Availability	1:1 thru 500:1
Radial load capacity	up to 11150 N
Mounting System	RediMount™

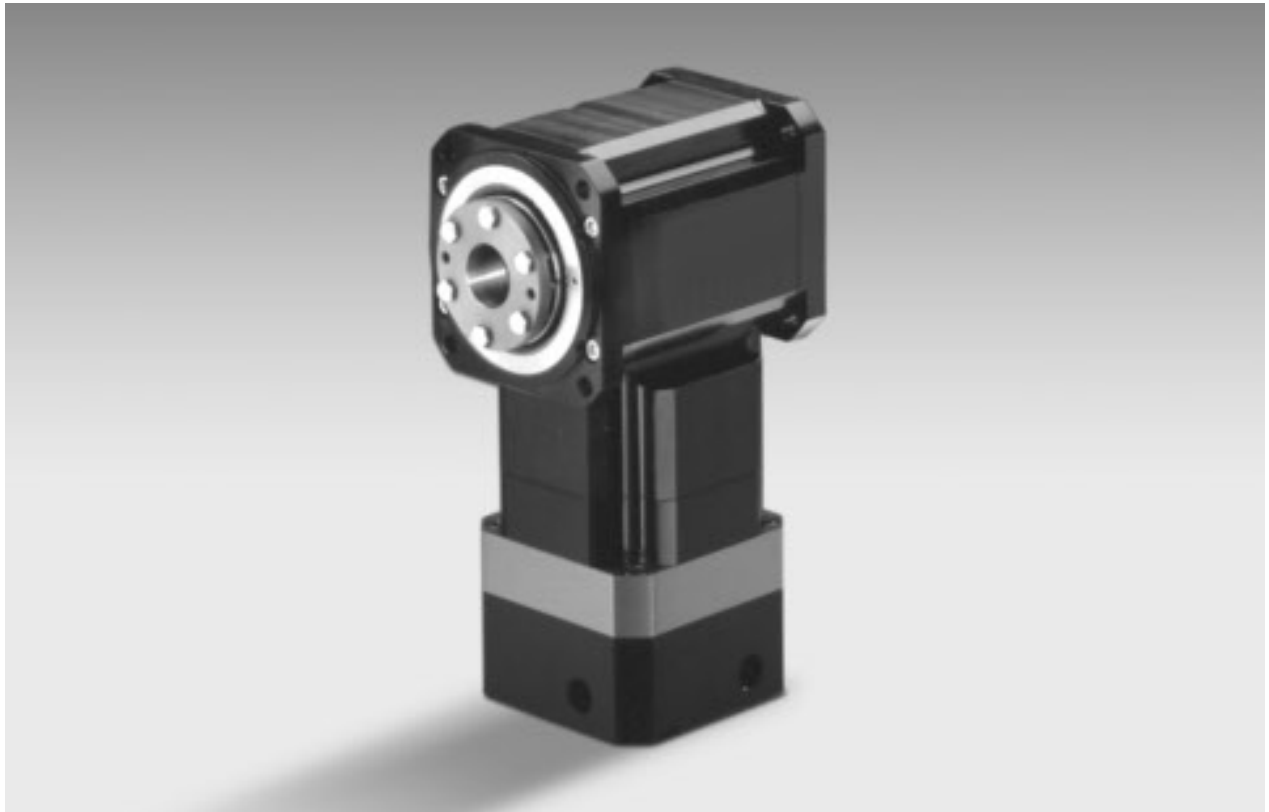

DuraTRUE 90™ Size 90H (Hollow Shaft)

Right Angle Gearheads

Metric

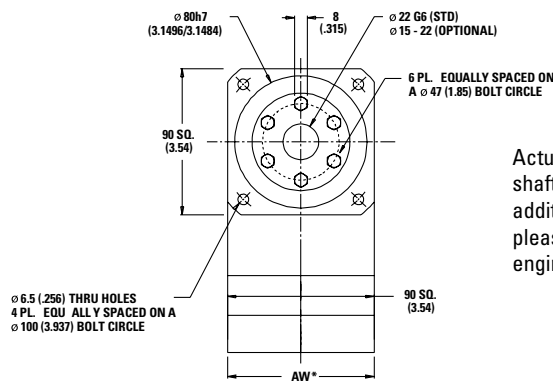
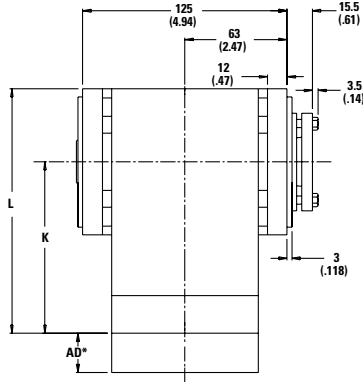

Actual thru bore of output shaft is larger than shown. For additional thru bore information, please contact application engineering.

Ratio ¹	Dimension 'K' mm [in]	Dimension 'L' mm [in]	Backlash [arc-min]	Weight kg [lb]	Efficiency
1:1 to 5:1P	101 [3.99]	146 [5.76]	8 max	4.1 [9]	98%
5:1T to 50:1	124 [4.89]	169 [6.66]	9 max	4.8 [10]	93%
60:1 to 500:1	147 [5.79]	192 [7.56]	9 max	5.5 [12]	88%

All dimensions are: mm (inch)
 AW* = Adapter width
 AD* = Adapter length
 Both will vary depending on motor.
 Efficiency is calculated at 100% of the rated torque.

Performance Specifications

Part Number	Ratio ¹	10,000 Hour Life				T peak Nm [in-lb]	20,000 Hour Life			J kg-cm ² [in-lb-sec ² x10 ⁻⁴]	Torsional Stiffness Nm/arc-min [in-lb/arc-min]
		T _r (1000 rpm) Nm [in-lb]	T _r (3000 rpm) Nm [in-lb]	T _r (5000 rpm) Nm [in-lb]	T _r (1000 rpm) Nm [in-lb]		T _r (3000 rpm) Nm [in-lb]	T _r (5000 rpm) Nm [in-lb]			
DTR90H-001	1:1	21 [188]	19 [171]	17 [155]	140 [1237]	20 [173]	18 [158]	16 [143]	3,11 [27.5]	4,3 [37.9]	
DTR90H-002	2:1	48 [426]	44 [389]	40 [352]	140 [1237]	44 [394]	41 [359]	37 [325]	1,59 [14.1]	6,5 [57.2]	
DTR90H-003	3:1	32 [281]	29 [256]	26 [232]	140 [1237]	29 [260]	27 [237]	24 [214]	1,37 [12.1]	7,3 [64.6]	
DTR90H-004	4:1	24 [215]	22 [196]	20 [177]	140 [1237]	22 [199]	20 [181]	19 [164]	1,27 [11.2]	7,6 [67.7]	
DTR90H-005P	5:1P	18 [158]	16 [144]	15 [131]	140 [1237]	17 [146]	15 [133]	14 [121]	1,25 [11.0]	7,8 [69.2]	
DTR90H-005T	5:1T	64 [568]	55 [483]	53 [469]	140 [1237]	63 [556]	50 [446]	49 [433]	1,64 [14.5]	5,1 [45.1]	
DTR90H-006	6:1	57 [501]	48 [426]	47 [414]	140 [1237]	55 [490]	44 [394]	43 [382]	1,63 [14.4]	5,1 [45.1]	
DTR90H-009	9:1	37 [331]	32 [281]	31 [273]	140 [1237]	37 [323]	29 [260]	28 [252]	1,37 [12.1]	6,4 [56.9]	
DTR90H-010	10:1	58 [516]	53 [471]	48 [426]	140 [1237]	58 [510]	51 [452]	44 [394]	1,54 [13.7]	5,0 [44.5]	
DTR90H-012	12:1	29 [253]	24 [215]	24 [209]	140 [1237]	28 [247]	22 [199]	22 [193]	1,31 [11.6]	7,1 [62.7]	
DTR90H-015	15:1	38 [340]	35 [311]	32 [281]	140 [1237]	38 [336]	34 [298]	29 [260]	1,28 [11.3]	7,4 [65.8]	
DTR90H-020	20:1	29 [261]	27 [238]	24 [215]	140 [1237]	29 [257]	26 [228]	22 [199]	1,22 [10.8]	7,1 [62.4]	
DTR90H-025	25:1	22 [192]	20 [175]	18 [158]	140 [1237]	21 [189]	19 [168]	17 [146]	1,20 [10.6]	7,4 [65.6]	
DTR90H-030	30:1	39 [348]	38 [333]	36 [318]	140 [1237]	39 [346]	37 [327]	35 [307]	1,25 [11.1]	6,1 [53.8]	
DTR90H-040	40:1	30 [266]	29 [255]	28 [243]	140 [1237]	30 [265]	28 [250]	27 [235]	1,19 [10.6]	6,8 [60.5]	
DTR90H-050	50:1	22 [196]	21 [188]	20 [179]	140 [1237]	22 [195]	21 [184]	20 [173]	1,17 [10.4]	7,3 [64.2]	
DTR90H-060	60:1	60 [535]	60 [527]	59 [520]	140 [1237]	60 [534]	59 [524]	58 [514]	1,63 [14.4]	4,9 [43.5]	
DTR90H-075	75:1	40 [352]	39 [346]	38 [340]	140 [1237]	40 [351]	39 [344]	38 [336]	1,31 [11.6]	6,4 [56.2]	
DTR90H-090	90:1	40 [353]	39 [348]	39 [343]	140 [1237]	40 [352]	39 [346]	38 [339]	1,37 [12.1]	6,3 [55.8]	
DTR90H-100	100:1	61 [536]	60 [532]	60 [527]	140 [1237]	61 [536]	60 [530]	59 [524]	1,55 [13.7]	5,0 [43.9]	
DTR90H-120	120:1	31 [270]	30 [266]	30 [262]	140 [1237]	30 [269]	30 [265]	29 [260]	1,31 [11.6]	7,0 [62.0]	
DTR90H-125	125:1	22 [198]	22 [195]	22 [192]	140 [1237]	22 [198]	22 [194]	21 [189]	1,23 [10.8]	7,4 [65.5]	
DTR90H-150	150:1	40 [354]	40 [351]	39 [348]	140 [1237]	40 [353]	39 [350]	39 [346]	1,29 [11.4]	6,3 [56.1]	
DTR90H-200	200:1	61 [538]	60 [535]	60 [533]	140 [1237]	61 [537]	60 [534]	60 [531]	1,52 [13.5]	4,6 [40.7]	
DTR90H-250	250:1	23 [199]	22 [198]	22 [196]	140 [1237]	22 [199]	22 [197]	22 [195]	1,21 [10.7]	7,4 [65.4]	
DTR90H-300	300:1	40 [355]	40 [353]	40 [352]	140 [1237]	40 [354]	40 [352]	40 [350]	1,26 [11.1]	6,1 [53.7]	
DTR90H-400	400:1	31 [271]	31 [270]	30 [269]	140 [1237]	31 [271]	30 [270]	30 [268]	1,20 [10.6]	6,8 [60.5]	
DTR90H-500	500:1	23 [200]	22 [199]	22 [198]	140 [1237]	23 [200]	22 [198]	22 [197]	1,18 [10.4]	7,3 [64.2]	

Ratio 5P is designed using only PowerTRUE face gearing technology.
 Ratio 5T adds a True Planetary gearing stage for increased torque capacity.
¹ Ratios are exact, higher ratios are also available, consult factory.

T_r = Rated output torque at rated speed for specific hours of life.
 J = Mass moment of inertia reflected to the input shaft (including pinion assembly)
 T_{peak} = Allowable momentary peak torque for emergency stop or heavy shock loading.

DuraTRUE 90™ Size 115H (Hollow Shaft)

Right Angle Gearheads

Metric

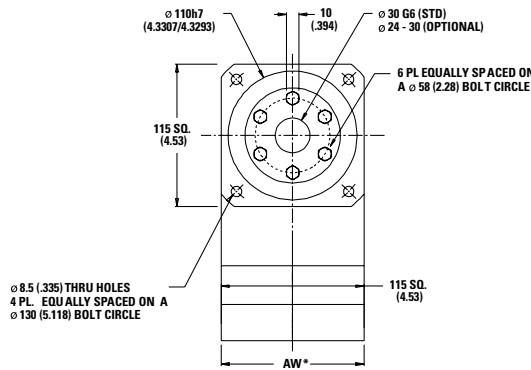
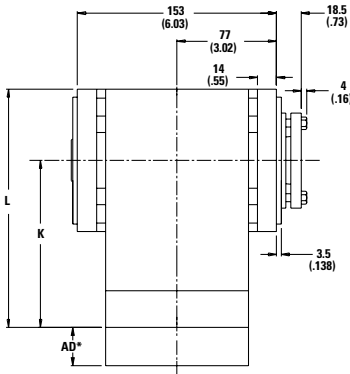

Actual thru bore of output shaft is larger than shown. For additional thru bore information, please contact application engineering.

Ratio ¹	Dimension 'K' mm [in]	Dimension 'L' mm [in]	Backlash [arc-min]	Weight kg [lb]	Efficiency
1:1 to 5:1P	137 [5.41]	195 [7.67]	8 max	9 [20]	98%
5:1T to 50:1	169 [6.64]	226 [8.90]	9 max	11 [24]	93%
60:1 to 500:1	200 [7.87]	257 [10.13]	9 max	12 [27]	88%

All dimensions are: mm (inch)
 AW* = Adapter width
 AD* = Adapter length
 Both will vary depending on motor.
 Efficiency is calculated at 100% of the rated torque.

Performance Specifications

Part Number	Ratio ¹	10,000 Hour Life			T peak Nm [in-lb]	20,000 Hour Life			J kg-cm ² [in-lb-sec ² x10 ⁻⁴]	Torsional Stiffness Nm/arc-min [in-lb/arc-min]
		T _r (1000 rpm) Nm [in-lb]	T _r (3000 rpm) Nm [in-lb]	T _r (5000 rpm) Nm [in-lb]		T _r (1000 rpm) Nm [in-lb]	T _r (3000 rpm) Nm [in-lb]	T _r (5000 rpm) Nm [in-lb]		
DTR115H-001	1:1	63 [554]	57 [506]	52 [457]	283 [2505]	58 [512]	53 [467]	48 [422]	5,28 [46.7]	7,6 [67.6]
DTR115H-002	2:1	112 [989]	102 [903]	92 [816]	283 [2505]	103 [913]	94 [834]	85 [754]	2,71 [23.9]	12,5 [111]
DTR115H-003	3:1	87 [768]	79 [701]	72 [634]	283 [2505]	80 [709]	73 [647]	66 [585]	2,33 [20.6]	14,2 [126]
DTR115H-004	4:1	58 [511]	53 [467]	48 [422]	283 [2505]	53 [472]	49 [431]	44 [390]	2,16 [19.1]	14,9 [132]
DTR115H-005P	5:1P	43 [384]	40 [350]	36 [316]	283 [2505]	40 [354]	37 [323]	33 [292]	2,12 [18.8]	15,3 [135]
DTR115H-005T	5:1T	170 [1505]	126 [1117]	108 [958]	283 [2505]	143 [1262]	102 [907]	88 [778]	2,78 [24.6]	15,3 [135]
DTR115H-006	6:1	131 [1163]	112 [989]	109 [960]	283 [2505]	129 [1138]	103 [913]	100 [887]	2,77 [24.5]	10,2 [90.7]
DTR115H-009	9:1	102 [903]	87 [768]	84 [746]	283 [2505]	100 [884]	80 [709]	78 [689]	2,32 [20.5]	12,8 [113]
DTR115H-010	10:1	135 [1198]	124 [1094]	112 [989]	283 [2505]	134 [1183]	118 [1048]	103 [913]	2,63 [23.2]	10,2 [90.3]
DTR115H-012	12:1	68 [601]	58 [511]	56 [496]	283 [2505]	66 [588]	53 [472]	52 [458]	2,22 [19.6]	14,0 [124]
DTR115H-015	15:1	105 [930]	96 [849]	87 [768]	283 [2505]	104 [919]	92 [814]	80 [709]	2,18 [19.3]	14,6 [130]
DTR115H-020	20:1	70 [619]	64 [565]	58 [511]	283 [2505]	69 [612]	61 [542]	53 [472]	2,08 [18.4]	14,0 [124]
DTR115H-025	25:1	52 [465]	48 [424]	43 [384]	283 [2505]	52 [459]	46 [406]	40 [354]	2,04 [18.0]	14,6 [129]
DTR115H-030	30:1	107 [951]	103 [910]	98 [869]	283 [2505]	107 [945]	101 [892]	95 [840]	2,13 [18.9]	12,5 [111]
DTR115H-040	40:1	72 [633]	68 [606]	65 [579]	283 [2505]	71 [629]	67 [594]	63 [559]	2,03 [18.0]	13,8 [122]
DTR115H-050	50:1	54 [475]	51 [454]	49 [434]	283 [2505]	53 [472]	50 [446]	47 [419]	1,99 [17.6]	14,5 [128]
DTR115H-060	60:1	140 [1242]	138 [1224]	136 [1207]	283 [2505]	140 [1239]	137 [1217]	135 [1194]	2,78 [24.6]	10,0 [88.5]
DTR115H-075	75:1	109 [963]	107 [947]	105 [930]	283 [2505]	109 [960]	106 [939]	104 [919]	2,22 [19.7]	12,7 [112]
DTR115H-090	90:1	109 [964]	107 [951]	106 [937]	283 [2505]	109 [962]	107 [945]	105 [927]	2,33 [20.6]	12,6 [112]
DTR115H-100	100:1	141 [1245]	140 [1235]	138 [1224]	283 [2505]	141 [1244]	137 [1230]	137 [1217]	2,64 [23.3]	10,1 [89.5]
DTR115H-120	120:1	73 [642]	72 [633]	70 [624]	283 [2505]	72 [641]	70 [629]	70 [617]	2,23 [19.7]	13,9 [123]
DTR115H-125	125:1	54 [481]	53 [473]	52 [465]	283 [2505]	54 [480]	52 [469]	52 [459]	2,08 [18.4]	14,6 [129]
DTR115H-150	150:1	109 [967]	108 [959]	107 [951]	283 [2505]	109 [966]	107 [955]	107 [945]	2,19 [19.4]	12,7 [112]
DTR115H-200	200:1	141 [1248]	140 [1243]	140 [1237]	283 [2505]	141 [1247]	139 [1240]	138 [1234]	2,59 [22.9]	9,8 [87.1]
DTR115H-250	250:1	55 [483]	54 [479]	54 [475]	283 [2505]	54 [482]	53 [477]	53 [472]	2,05 [18.1]	14,6 [129]
DTR115H-300	300:1	109 [969]	109 [965]	109 [961]	283 [2505]	109 [968]	108 [963]	108 [958]	2,14 [18.9]	12,5 [111]
DTR115H-400	400:1	73 [645]	73 [642]	72 [640]	283 [2505]	73 [645]	72 [641]	72 [638]	2,04 [18.1]	13,8 [122]
DTR115H-500	500:1	55 [484]	54 [482]	54 [480]	283 [2505]	55 [483]	54 [481]	54 [478]	2,00 [17.7]	14,5 [128]

Ratio 5P is designed using only PowerTRUE face gearing technology.
 Ratio 5T adds a True Planetary gearing stage for increased torque capacity.
¹ Ratios are exact, higher ratios are also available, consult factory.

T_r = Rated output torque at rated speed for specific hours of life.
 J = Mass moment of inertia reflected to the input shaft (including pinion assembly)
 T_{peak} = Allowable momentary peak torque for emergency stop or heavy shock loading.

DuraTRUE 90™ Size 142H (Hollow Shaft)

Right Angle Gearheads

Metric

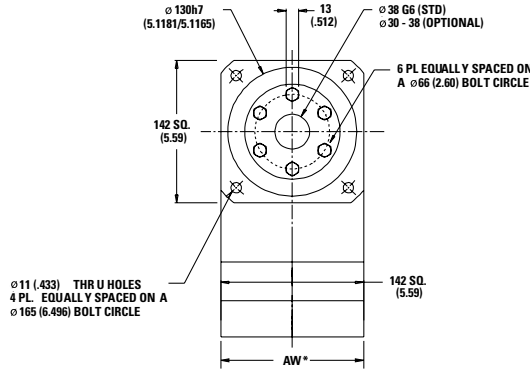
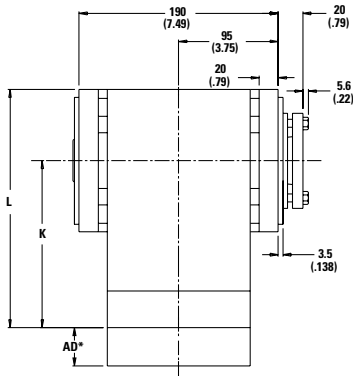

Actual thru bore of output shaft is larger than shown. For additional thru bore information, please contact application engineering.

Ratio ¹	Dimension 'K' mm [in]	Dimension 'L' mm [in]	Backlash [arc-min]	Weight kg [lb]	Efficiency
1:1 to 5:1P	163 [6.43]	234 [9.22]	8 max	19 [43]	98%
5:1T to 50:1	233 [9.17]	304 [11.96]	9 max	24 [53]	93%
60:1 to 500:1	262 [10.3]	332 [13.10]	9 max	28 [62]	88%

All dimensions are: mm (inch)
 AW* = Adapter width
 AD* = Adapter length
 Both will vary depending on motor.
 Efficiency is calculated at 100% of the rated torque.

Performance Specifications

Part Number	Ratio ¹	10,000 Hour Life			T peak Nm [in-lb]	20,000 Hour Life			J kg-cm ² [in-lb-sec ² x10 ⁻⁴]	Torsional Stiffness Nm/arc-min [in-lb/arc-min]
		T _r (1000 rpm) Nm [in-lb]	T _r (3000 rpm) Nm [in-lb]	T _r (5000 rpm) Nm [in-lb]		T _r (1000 rpm) Nm [in-lb]	T _r (3000 rpm) Nm [in-lb]	T _r (5000 rpm) Nm [in-lb]		
DTR142H-001	1:1	135 [1194]	123 [1090]	111 [985]	865 [7659]	125 [1103]	114 [1006]	103 [910]	26.3 [232]	23.7 [210]
DTR142H-002	2:1	279 [2474]	255 [2257]	231 [2041]	865 [7659]	258 [2284]	236 [2084]	213 [1885]	13.5 [119]	38.9 [344]
DTR142H-003	3:1	188 [1663]	171 [1518]	155 [1372]	865 [7659]	174 [1536]	158 [1401]	143 [1267]	11.6 [102]	44.1 [390]
DTR142H-004	4:1	135 [1194]	123 [1090]	111 [985]	865 [7659]	125 [1103]	114 [1006]	103 [910]	10.8 [95.1]	46.3 [410]
DTR142H-005P	5:1P	101 [896]	92 [818]	84 [739]	865 [7659]	93 [827]	85 [755]	77 [683]	10.6 [93.3]	47.4 [419]
DTR142H-005T	5:1T	340 [3009]	289 [2559]	281 [2484]	865 [7659]	333 [2944]	267 [2363]	259 [2294]	13.8 [122]	47.4 [419]
DTR142H-006	6:1	329 [2909]	279 [2474]	271 [2402]	865 [7659]	322 [2846]	258 [2284]	251 [2218]	13.8 [122]	31.8 [281]
DTR142H-009	9:1	221 [1956]	188 [1663]	182 [1614]	865 [7659]	216 [1913]	174 [1536]	168 [1491]	11.6 [102]	39.6 [351]
DTR142H-010	10:1	339 [2996]	309 [2735]	279 [2474]	865 [7659]	334 [2958]	296 [2621]	258 [2284]	13.1 [116]	31.6 [280]
DTR142H-012	12:1	159 [1404]	135 [1194]	131 [1159]	865 [7659]	155 [1374]	125 [1103]	121 [1071]	11.1 [97.7]	43.4 [384]
DTR142H-015	15:1	228 [2014]	208 [1839]	188 [1663]	865 [7659]	225 [1989]	199 [1762]	174 [1536]	10.9 [95.9]	45.4 [402]
DTR142H-020	20:1	163 [1446]	149 [1320]	135 [1194]	865 [7659]	161 [1428]	143 [1265]	125 [1103]	10.4 [91.5]	43.3 [383]
DTR142H-025	25:1	123 [1085]	112 [991]	101 [896]	865 [7659]	121 [1071]	107 [949]	93 [827]	10.2 [89.8]	45.3 [401]
DTR142H-030	30:1	233 [2058]	223 [1970]	213 [1882]	865 [7659]	231 [2045]	218 [1932]	205 [1819]	10.6 [93.8]	38.8 [343]
DTR142H-040	40:1	167 [1478]	160 [1415]	153 [1352]	865 [7659]	166 [1469]	157 [1387]	148 [1306]	10.1 [89.4]	42.8 [379]
DTR142H-050	50:1	125 [1109]	120 [1061]	115 [1014]	865 [7659]	125 [1102]	118 [1041]	111 [980]	9.91 [87.6]	45.0 [398]
DTR142H-060	60:1	351 [3105]	346 [3061]	341 [3018]	865 [7659]	350 [3099]	344 [3042]	337 [2986]	13.8 [122]	31.0 [274]
DTR142H-075	75:1	236 [2084]	232 [2049]	228 [2014]	865 [7659]	235 [2079]	230 [2034]	225 [1989]	11.1 [97.9]	39.4 [348]
DTR142H-090	90:1	236 [2087]	233 [2058]	229 [2029]	865 [7659]	235 [2083]	231 [2045]	227 [2008]	11.6 [103]	39.1 [346]
DTR142H-100	100:1	352 [3114]	349 [3088]	346 [3061]	865 [7659]	351 [3110]	348 [3076]	344 [3042]	13.1 [116]	31.3 [278]
DTR142H-120	120:1	169 [1499]	167 [1478]	165 [1457]	865 [7659]	169 [1496]	166 [1469]	163 [1442]	11.1 [98.2]	43.0 [380]
DTR142H-125	125:1	127 [1123]	125 [1104]	123 [1085]	865 [7659]	127 [1120]	124 [1096]	121 [1071]	10.4 [91.7]	45.3 [401]
DTR142H-150	150:1	237 [2093]	235 [2076]	233 [2058]	865 [7659]	236 [2091]	234 [2068]	231 [2045]	10.9 [96.4]	39.3 [348]
DTR142H-200	200:1	353 [3120]	351 [3107]	350 [3094]	865 [7659]	352 [3118]	350 [3101]	349 [3085]	12.9 [114]	30.5 [270]
DTR142H-250	250:1	127 [1128]	126 [1118]	125 [1109]	865 [7659]	127 [1126]	126 [1114]	125 [1102]	10.2 [90.3]	45.2 [400]
DTR142H-300	300:1	237 [2098]	236 [2089]	235 [2080]	865 [7659]	237 [2096]	236 [2085]	234 [2074]	10.7 [94.3]	38.8 [343]
DTR142H-400	400:1	170 [1506]	169 [1500]	169 [1494]	865 [7659]	170 [1505]	169 [1497]	168 [1489]	10.2 [89.8]	42.8 [379]
DTR142H-500	500:1	128 [1130]	127 [1125]	127 [1121]	865 [7659]	128 [1129]	127 [1123]	126 [1117]	9.96 [88.1]	45.0 [398]

Ratio 5P is designed using only PowerTRUE face gearing technology.
 Ratio 5T adds a True Planetary gearing stage for increased torque capacity.
¹ Ratios are exact, higher ratios are also available, consult factory.

T_r = Rated output torque at rated speed for specific hours of life.
 J = Mass moment of inertia reflected to the input shaft (including pinion assembly)
 T_{peak} = Allowable momentary peak torque for emergency stop or heavy shock loading.

Radial and Axial Load Ratings

DTR90H

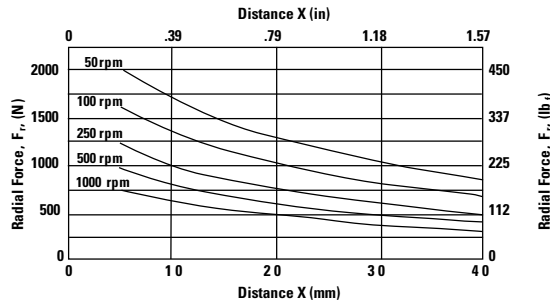
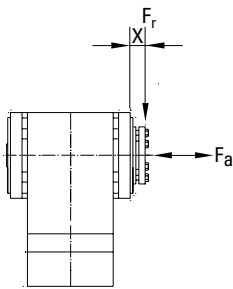

Speed rpm	Axial Load, F_a N [lb _f]
50	3157 [710]
100	2506 [563]
250	1846 [415]
500	1465 [329]
1000	1163 [261]

DTR115H

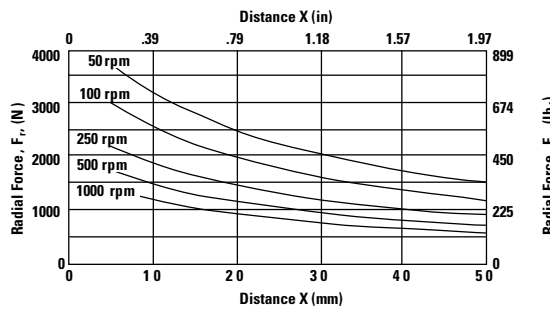
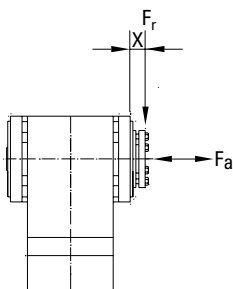

Speed rpm	Axial Load, F_a N [lb _f]
50	5742 [1291]
100	4558 [1025]
250	3358 [755]
500	2665 [599]
1000	2115 [476]

DTR142H

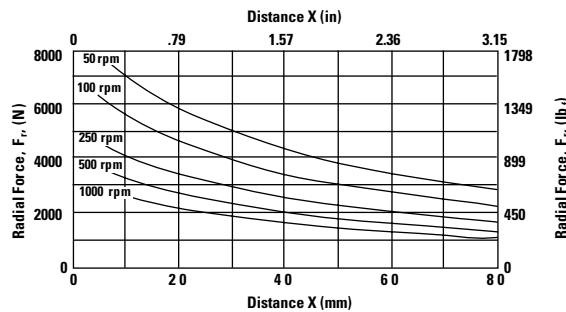
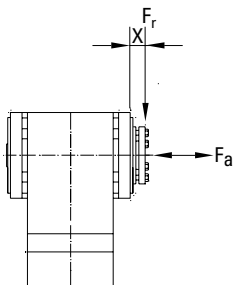

Speed rpm	Axial Load, F_a N [lb _f]
50	11925 [2681]
100	9465 [2128]
250	6974 [1568]
500	5535 [1244]
1000	4393 [988]

These graphs display the allowable radial load at a given distance (X) from the mounting surface based on an L_{10} life of 10,000 hours for the mean output speed n_{mout} , as described on page 10.



DuraTRUE 90™ Dual Shaft

Right Angle Gearheads

Ready for Immediate Delivery	
Precision	8 arc-minutes
Frame Sizes	60mm, 90mm, 115mm and 142mm
Torque Capacity	up to 865 Nm
Ratio Availability	1:1 thru 500:1
Radial load capacity	up to 11150 N
Mounting System	RediMount™

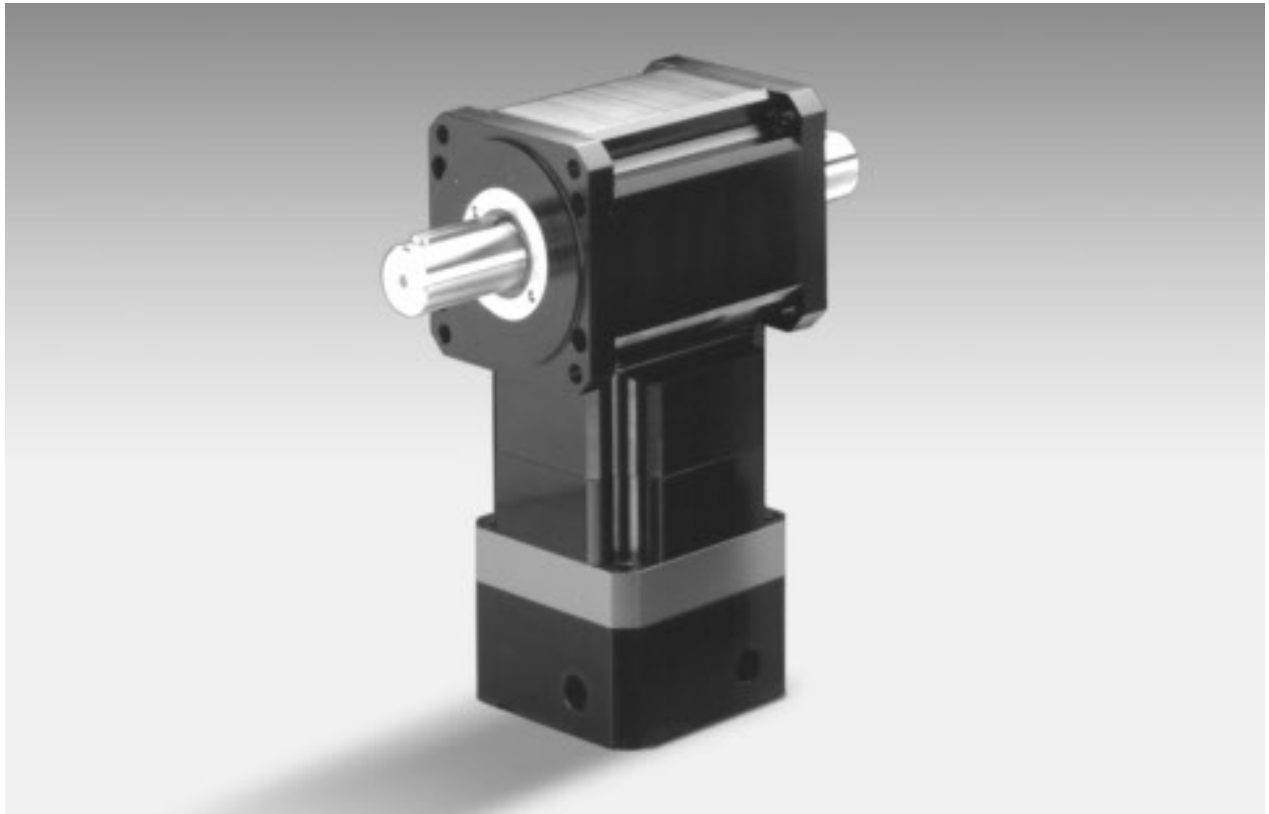

DuraTRUE 90™ Size 60D (Dual Shaft)

Right Angle Gearheads

Metric

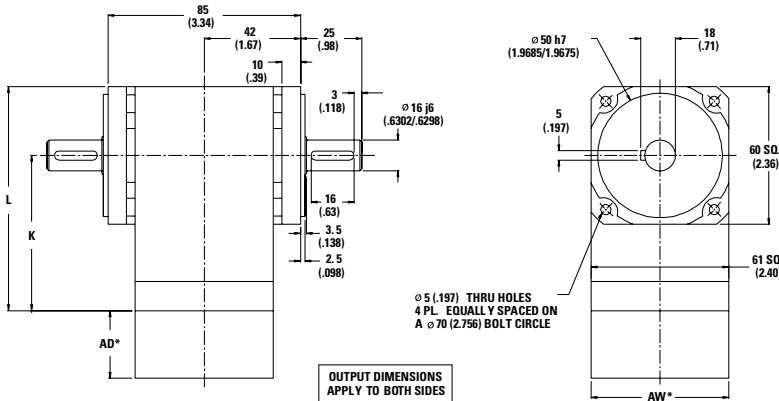

Ratio ¹	Dimension 'K' mm [in]	Dimension 'L' mm [in]	Backlash [arc-min]	Weight kg [lb]	Efficiency
1:1 to 5:1P	80 [3.15]	110 [4.33]	8 max	2,3 [5]	98%
5:1T to 50:1	97 [3.83]	127 [5.01]	9 max	2,5 [5.5]	93%
60:1 to 500:1	115 [4.52]	145 [5.70]	9 max	2,7 [6]	88%

All dimensions are: mm (inch)
 AW* = Adapter width
 AD* = Adapter length
 Both will vary depending on motor.
 Efficiency is calculated at 100% of the rated torque.

Performance Specifications

Part Number	Ratio ¹	10,000 Hour Life			T peak Nm [in-lb]	20,000 Hour Life			J kg-cm ² [in-lb-sec ² ×10 ⁻⁴]	Torsional Stiffness Nm/arc-min [in-lb/arc-min]
		T _r (1000 rpm) Nm [in-lb]	T _r (3000 rpm) Nm [in-lb]	T _r (5000 rpm) Nm [in-lb]		T _r (1000 rpm) Nm [in-lb]	T _r (3000 rpm) Nm [in-lb]	T _r (5000 rpm) Nm [in-lb]		
DTR60D-001	1:1	7 [66]	7 [60]	6 [54]	46 [407]	7 [61]	6 [56]	6 [50]	,79 [7.0]	1,8 [15.8]
DTR60D-002	2:1	16 [145]	15 [132]	14 [120]	46 [407]	15 [134]	14 [122]	12 [111]	,41 [3.6]	2,7 [23.8]
DTR60D-003	3:1	10 [92]	10 [84]	9 [76]	46 [407]	10 [85]	9 [78]	8 [70]	,35 [3.1]	3,0 [26.9]
DTR60D-004	4:1	8 [68]	7 [62]	6 [56]	46 [407]	7 [63]	6 [57]	6 [52]	,32 [2.9]	3,2 [28.2]
DTR60D-005P	5:1P	6 [56]	6 [51]	5 [46]	46 [407]	6 [52]	5 [47]	5 [43]	,32 [2.8]	3,3 [28.8]
DTR60D-005T	5:1T	23 [200]	18 [162]	16 [138]	46 [407]	21 [182]	15 [132]	13 [112]	,42 [3.7]	3,3 [28.8]
DTR60D-006	6:1	19 [171]	16 [145]	16 [141]	46 [407]	19 [167]	15 [134]	15 [130]	,41 [3.7]	2,1 [18.8]
DTR60D-009	9:1	12 [109]	10 [92]	10 [90]	46 [407]	12 [106]	10 [85]	9 [83]	,35 [3.1]	2,7 [23.7]
DTR60D-010	10:1	20 [176]	18 [160]	16 [145]	46 [407]	20 [174]	17 [154]	15 [134]	,39 [3.5]	2,1 [18.5]
DTR60D-012	12:1	9 [80]	8 [68]	7 [66]	46 [407]	9 [78]	7 [63]	7 [61]	,33 [3.0]	3,0 [26.1]
DTR60D-015	15:1	13 [112]	12 [102]	10 [92]	46 [407]	12 [110]	11 [98]	10 [85]	,33 [2.9]	3,1 [27.4]
DTR60D-020	20:1	9 [82]	8 [75]	8 [68]	46 [407]	9 [81]	8 [72]	7 [63]	,31 [2.8]	2,9 [26.0]
DTR60D-025	25:1	8 [68]	7 [62]	6 [56]	46 [407]	8 [67]	7 [59]	6 [52]	,31 [2.7]	3,1 [27.3]
DTR60D-030	30:1	13 [114]	12 [109]	12 [105]	46 [407]	13 [114]	12 [107]	11 [101]	,32 [2.8]	2,5 [22.4]
DTR60D-040	40:1	10 [84]	9 [81]	9 [77]	46 [407]	9 [84]	9 [79]	8 [74]	,30 [2.7]	2,8 [25.2]
DTR60D-050	50:1	8 [69]	7 [66]	7 [63]	46 [407]	8 [69]	7 [65]	7 [61]	,30 [2.6]	3,0 [26.8]
DTR60D-060	60:1	21 [182]	20 [180]	20 [177]	46 [407]	21 [182]	20 [178]	20 [175]	,42 [3.7]	2,0 [18.1]
DTR60D-075	75:1	13 [116]	13 [114]	13 [112]	46 [407]	13 [115]	13 [113]	12 [110]	,33 [3.0]	2,6 [23.4]
DTR60D-090	90:1	13 [116]	13 [114]	13 [113]	46 [407]	13 [116]	13 [114]	13 [111]	,35 [3.1]	2,6 [23.3]
DTR60D-100	100:1	21 [183]	20 [181]	20 [180]	46 [407]	21 [182]	20 [180]	20 [178]	,40 [3.5]	2,1 [18.3]
DTR60D-120	120:1	10 [85]	10 [84]	9 [83]	46 [407]	10 [85]	9 [84]	9 [82]	,33 [3.0]	2,9 [25.8]
DTR60D-125	125:1	8 [70]	8 [69]	8 [68]	46 [407]	8 [70]	8 [68]	8 [67]	,31 [2.8]	3,1 [27.3]
DTR60D-150	150:1	13 [116]	13 [115]	13 [114]	46 [407]	13 [116]	13 [115]	13 [114]	,33 [2.9]	2,6 [23.4]
DTR60D-200	200:1	21 [183]	21 [182]	21 [181]	46 [407]	21 [183]	21 [182]	20 [181]	,39 [3.4]	1,9 [17.0]
DTR60D-250	250:1	8 [70]	8 [70]	8 [69]	46 [407]	8 [70]	8 [69]	8 [69]	,31 [2.7]	3,1 [27.3]
DTR60D-300	300:1	13 [116]	13 [116]	13 [115]	46 [407]	13 [116]	13 [116]	13 [115]	,32 [2.8]	2,5 [22.4]
DTR60D-400	400:1	10 [86]	10 [85]	10 [85]	46 [407]	10 [86]	10 [85]	10 [85]	,31 [2.7]	2,8 [25.2]
DTR60D-500	500:1	8 [70]	8 [70]	8 [70]	46 [407]	8 [70]	8 [70]	8 [70]	,30 [2.7]	3,0 [26.8]

Ratio 5P is designed using only PowerTRUE face gearing technology.
 Ratio 5T adds a True Planetary gearing stage for increased torque capacity.
¹ Ratios are exact, higher ratios are also available, consult factory.

T_r = Rated output torque at rated speed for specific hours of life.
 J = Mass moment of inertia reflected to the input shaft (including pinion assembly)
 T_{peak} = Allowable momentary peak torque for emergency stop or heavy shock loading.

DuraTRUE 90™ Size 90D (Dual Shaft)

Right Angle Gearheads

Metric

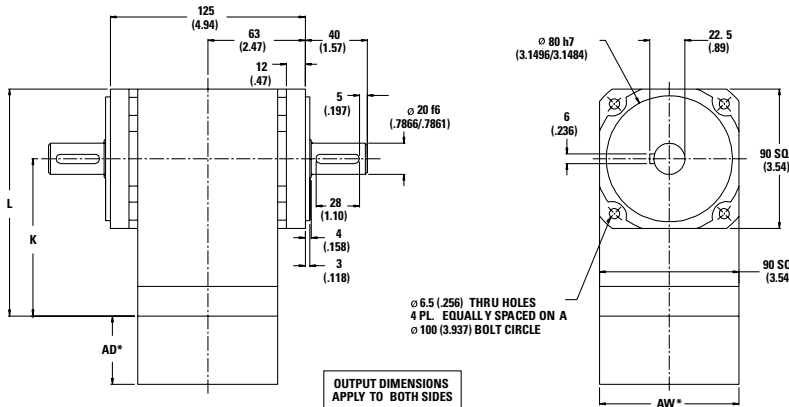

Ratio ¹	Dimension 'K' mm [in]	Dimension 'L' mm [in]	Backlash [arc-min]	Weight kg [lb]	Efficiency
1:1 to 5:1P	101 [3.99]	146 [5.76]	8 max	4,1 [9]	98%
5:1T to 50:1	124 [4.89]	169 [6.66]	9 max	4,8 [10]	93%
60:1 to 500:1	147 [5.79]	192 [7.56]	9 max	5,5 [12]	88%

All dimensions are: mm (inch)
 AW* = Adapter width
 AD* = Adapter length
 Both will vary depending on motor.
 Efficiency is calculated at 100% of the rated torque.

Performance Specifications

Part Number	Ratio ¹	10,000 Hour Life				T peak Nm [in-lb]	20,000 Hour Life			J kg-cm ² [in-lb-sec ² x10 ⁻⁴]	Torsional Stiffness Nm/arc-min [in-lb/arc-min]
		T _r (1000 rpm) Nm [in-lb]	T _r (3000 rpm) Nm [in-lb]	T _r (5000 rpm) Nm [in-lb]	T _r (1000 rpm) Nm [in-lb]		T _r (3000 rpm) Nm [in-lb]	T _r (5000 rpm) Nm [in-lb]			
DTR90D-001	1:1	21 [188]	19 [171]	17 [155]	140 [1237]	20 [173]	18 [158]	16 [143]	3,11 [27.5]	4,3 [37.9]	
DTR90D-002	2:1	48 [426]	44 [389]	40 [352]	140 [1237]	44 [394]	41 [359]	37 [325]	1,59 [14.1]	6,5 [57.2]	
DTR90D-003	3:1	32 [281]	29 [256]	26 [232]	140 [1237]	29 [260]	27 [237]	24 [214]	1,37 [12.1]	7,3 [64.6]	
DTR90D-004	4:1	24 [215]	22 [196]	20 [177]	140 [1237]	22 [199]	20 [181]	19 [164]	1,27 [11.2]	7,6 [67.7]	
DTR90D-005P	5:1P	18 [158]	16 [144]	15 [131]	140 [1237]	17 [146]	15 [133]	14 [121]	1,25 [11.0]	7,8 [69.2]	
DTR90D-005T	5:1T	64 [568]	55 [483]	53 [469]	140 [1237]	63 [556]	50 [446]	49 [433]	1,64 [14.5]	5,1 [45.1]	
DTR90D-006	6:1	57 [501]	48 [426]	47 [414]	140 [1237]	55 [490]	44 [394]	43 [382]	1,63 [14.4]	5,1 [45.1]	
DTR90D-009	9:1	37 [331]	32 [281]	31 [273]	140 [1237]	37 [323]	29 [260]	28 [252]	1,37 [12.1]	6,4 [56.9]	
DTR90D-010	10:1	58 [516]	53 [471]	48 [426]	140 [1237]	58 [510]	51 [452]	44 [394]	1,54 [13.7]	5,0 [44.5]	
DTR90D-012	12:1	29 [253]	24 [215]	24 [209]	140 [1237]	28 [247]	22 [199]	22 [193]	1,31 [11.6]	7,1 [62.7]	
DTR90D-015	15:1	38 [340]	35 [311]	32 [281]	140 [1237]	38 [336]	34 [298]	29 [260]	1,28 [11.3]	7,4 [65.8]	
DTR90D-020	20:1	29 [261]	27 [238]	24 [215]	140 [1237]	29 [257]	26 [228]	22 [199]	1,22 [10.8]	7,1 [62.4]	
DTR90D-025	25:1	22 [192]	20 [175]	18 [158]	140 [1237]	21 [189]	19 [168]	17 [146]	1,20 [10.6]	7,4 [65.6]	
DTR90D-030	30:1	39 [348]	38 [333]	36 [318]	140 [1237]	39 [346]	37 [327]	35 [307]	1,25 [11.1]	6,1 [53.8]	
DTR90D-040	40:1	30 [266]	29 [255]	28 [243]	140 [1237]	30 [265]	28 [250]	27 [235]	1,19 [10.6]	6,8 [60.5]	
DTR90D-050	50:1	22 [196]	21 [188]	20 [179]	140 [1237]	22 [195]	21 [184]	20 [173]	1,17 [10.4]	7,3 [64.2]	
DTR90D-060	60:1	60 [535]	60 [527]	59 [520]	140 [1237]	60 [534]	59 [524]	58 [514]	1,63 [14.4]	4,9 [43.5]	
DTR90D-075	75:1	40 [352]	39 [346]	38 [340]	140 [1237]	40 [351]	39 [344]	38 [336]	1,31 [11.6]	6,4 [56.2]	
DTR90D-090	90:1	40 [353]	39 [348]	39 [343]	140 [1237]	40 [352]	39 [346]	38 [339]	1,37 [12.1]	6,3 [55.8]	
DTR90D-100	100:1	61 [536]	60 [532]	60 [527]	140 [1237]	61 [536]	60 [530]	59 [524]	1,55 [13.7]	5,0 [43.9]	
DTR90D-120	120:1	31 [270]	30 [266]	30 [262]	140 [1237]	30 [269]	30 [265]	29 [260]	1,31 [11.6]	7,0 [62.0]	
DTR90D-125	125:1	22 [198]	22 [195]	22 [192]	140 [1237]	22 [198]	22 [194]	21 [189]	1,23 [10.8]	7,4 [65.5]	
DTR90D-150	150:1	40 [354]	40 [351]	39 [348]	140 [1237]	40 [353]	39 [350]	39 [346]	1,29 [11.4]	6,3 [56.1]	
DTR90D-200	200:1	61 [538]	60 [535]	60 [533]	140 [1237]	61 [537]	60 [534]	60 [531]	1,52 [13.5]	4,6 [40.7]	
DTR90D-250	250:1	23 [199]	22 [198]	22 [196]	140 [1237]	22 [199]	22 [197]	22 [195]	1,21 [10.7]	7,4 [65.4]	
DTR90D-300	300:1	40 [355]	40 [353]	40 [352]	140 [1237]	40 [354]	40 [352]	40 [350]	1,26 [11.1]	6,1 [53.7]	
DTR90D-400	400:1	31 [271]	31 [270]	30 [269]	140 [1237]	31 [271]	30 [270]	30 [268]	1,20 [10.6]	6,8 [60.5]	
DTR90D-500	500:1	23 [200]	22 [199]	22 [198]	140 [1237]	23 [200]	22 [198]	22 [197]	1,18 [10.4]	7,3 [64.2]	

Ratio 5P is designed using only PowerTRUE face gearing technology.
 Ratio 5T adds a True Planetary gearing stage for increased torque capacity.
¹ Ratios are exact, higher ratios are also available, consult factory.

T_r = Rated output torque at rated speed for specific hours of life.
 J = Mass moment of inertia reflected to the input shaft (including pinion assembly)
 T_{peak} = Allowable momentary peak torque for emergency stop or heavy shock loading.

DuraTRUE 90™ Size 115D (Dual Shaft)

Right Angle Gearheads

Metric

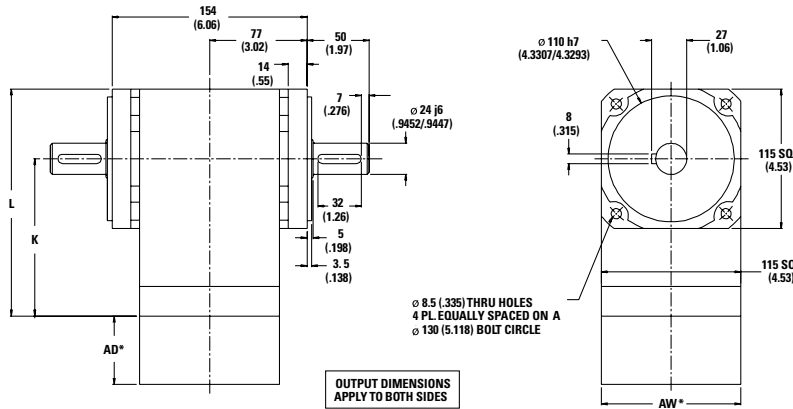

Ratio ¹	Dimension 'K' mm [in]	Dimension 'L' mm [in]	Backlash [arc-min]	Weight kg [lb]	Efficiency
1:1 to 5:1P	137 (5.41)	195 (7.76)	8 max	9 [20]	98%
5:1T to 50:1	169 (6.64)	226 (8.90)	9 max	11 [24]	93%
60:1 to 500:1	200 (7.87)	257 (10.13)	9 max	12 [27]	88%

All dimensions are: mm (inch)
 AW* = Adapter width
 AD* = Adapter length
 Both will vary depending on motor.
 Efficiency is calculated at 100% of the rated torque.

Performance Specifications

Part Number	Ratio ¹	10,000 Hour Life			T peak Nm [in-lb]	20,000 Hour Life			J kg-cm ² [in-lb-sec ² x10 ⁻⁴]	Torsional Stiffness [arc-min/Nm]
		T _r (1000 rpm) Nm [in-lb]	T _r (3000 rpm) Nm [in-lb]	T _r (5000 rpm) Nm [in-lb]		T _r (1000 rpm) Nm [in-lb]	T _r (3000 rpm) Nm [in-lb]	T _r (5000 rpm) Nm [in-lb]		
DTR115D-001	1:1	63 [554]	57 [506]	52 [457]	283 [2505]	58 [512]	53 [467]	48 [422]	5,28 [46.7]	7,6 [67.6]
DTR115D-002	2:1	112 [989]	102 [903]	92 [816]	283 [2505]	103 [913]	94 [834]	85 [754]	2,71 [23.9]	12,5 [111]
DTR115D-003	3:1	87 [768]	79 [701]	72 [634]	283 [2505]	80 [709]	73 [647]	66 [585]	2,33 [20.6]	14,2 [126]
DTR115D-004	4:1	58 [511]	53 [467]	48 [422]	283 [2505]	53 [472]	49 [431]	44 [390]	2,16 [19.1]	14,9 [132]
DTR115D-005P	5:1P	43 [384]	40 [350]	36 [316]	283 [2505]	40 [354]	37 [323]	33 [292]	2,12 [18.8]	15,3 [135]
DTR115D-005T	5:1T	170 [1505]	126 [1117]	108 [958]	283 [2505]	143 [1262]	102 [907]	88 [778]	2,78 [24.6]	15,3 [135]
DTR115D-006	6:1	131 [1163]	112 [989]	109 [960]	283 [2505]	129 [1138]	103 [913]	100 [887]	2,77 [24.5]	10,2 [90.7]
DTR115D-009	9:1	102 [903]	87 [768]	84 [746]	283 [2505]	100 [884]	80 [709]	78 [689]	2,32 [20.5]	12,8 [113]
DTR115D-010	10:1	135 [1198]	124 [1094]	112 [989]	283 [2505]	134 [1183]	118 [1048]	103 [913]	2,63 [23.2]	10,2 [90.3]
DTR115D-012	12:1	68 [601]	58 [511]	56 [496]	283 [2505]	66 [588]	53 [472]	52 [458]	2,22 [19.6]	14,0 [124]
DTR115D-015	15:1	105 [930]	96 [849]	87 [768]	283 [2505]	104 [919]	92 [814]	80 [709]	2,18 [19.3]	14,6 [130]
DTR115D-020	20:1	70 [619]	64 [565]	58 [511]	283 [2505]	69 [612]	61 [542]	53 [472]	2,08 [18.4]	14,0 [124]
DTR115D-025	25:1	52 [465]	48 [424]	43 [384]	283 [2505]	52 [459]	46 [406]	40 [354]	2,04 [18.0]	14,6 [129]
DTR115D-030	30:1	107 [951]	103 [910]	98 [869]	283 [2505]	107 [945]	101 [892]	95 [840]	2,13 [18.9]	12,5 [111]
DTR115D-040	40:1	72 [633]	68 [606]	65 [579]	283 [2505]	71 [629]	67 [594]	63 [559]	2,03 [18.0]	13,8 [122]
DTR115D-050	50:1	54 [475]	51 [454]	49 [434]	283 [2505]	53 [472]	50 [446]	47 [419]	1,99 [17.6]	14,5 [128]
DTR115D-060	60:1	140 [1242]	138 [1224]	136 [1207]	283 [2505]	140 [1239]	137 [1217]	135 [1194]	2,78 [24.6]	10,0 [88.5]
DTR115D-075	75:1	109 [963]	107 [947]	105 [930]	283 [2505]	109 [960]	106 [939]	104 [919]	[2,22 19.7]	12,7 [112]
DTR115D-090	90:1	109 [964]	107 [951]	106 [937]	283 [2505]	109 [962]	107 [945]	105 [927]	2,33 [20.6]	12,6 [112]
DTR115D-100	100:1	141 [1245]	140 [1235]	138 [1224]	283 [2505]	141 [1244]	139 [1230]	137 [1217]	2,64 [23.3]	10,1 [89.5]
DTR115D-120	120:1	73 [642]	72 [633]	70 [624]	283 [2505]	72 [641]	71 [629]	70 [617]	2,23 [19.7]	13,9 [123]
DTR115D-125	125:1	54 [481]	53 [473]	52 [465]	283 [2505]	54 [480]	53 [469]	52 [459]	2,08 [18.4]	14,6 [129]
DTR115D-150	150:1	109 [967]	108 [959]	107 [951]	283 [2505]	109 [966]	108 [955]	107 [945]	2,19 [19.4]	12,7 [112]
DTR115D-200	200:1	141 [1248]	140 [1243]	140 [1237]	283 [2505]	141 [1247]	140 [1240]	139 [1234]	2,59 [22.9]	9,8 [87.1]
DTR115D-250	250:1	55 [483]	54 [479]	54 [475]	283 [2505]	54 [482]	54 [477]	53 [472]	2,05 [18.1]	14,6 [129]
DTR115D-300	300:1	109 [969]	109 [965]	109 [961]	283 [2505]	109 [968]	109 [963]	108 [958]	2,14 [18.9]	12,5 [111]
DTR115D-400	400:1	73 [645]	73 [642]	73 [640]	283 [2505]	73 [645]	72 [641]	72 [638]	2,04 [18.1]	13,8 [122]
DTR115D-500	500:1	55 [484]	54 [482]	54 [480]	283 [2505]	55 [483]	54 [481]	54 [478]	2,00 [17.7]	14,5 [128]

Ratio 5P is designed using only PowerTRUE face gearing technology.
 Ratio 5T adds a True Planetary gearing stage for increased torque capacity.
¹ Ratios are exact, higher ratios are also available, consult factory.

T_r = Rated output torque at rated speed for specific hours of life.
 J = Mass moment of inertia reflected to the input shaft (including pinion assembly)
 T_{peak} = Allowable momentary peak torque for emergency stop or heavy shock loading.

DuraTRUE 90™ Size 142D (Dual Shaft)

Right Angle Gearheads

Metric

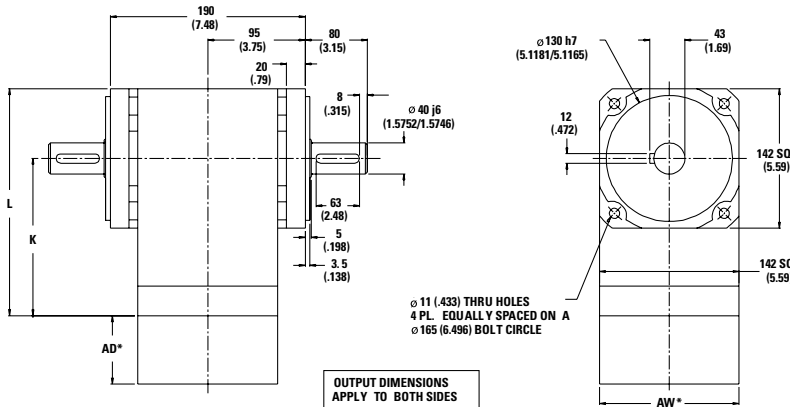

Ratio ¹	Dimension 'K' mm [in]	Dimension 'L' mm [in]	Backlash [arc-min]	Weight kg [lb]	Efficiency
1:1 to 5:1P	163 [6.43]	234 [9.22]	8 max	19 [43]	98%
5:1T to 50:1	233 [9.17]	304 [11.96]	9 max	24 [53]	93%
60:1 to 500:1	262 [10.3]	332 [13.10]	9 max	28 [62]	88%

All dimensions are: mm (inch)
 AW* = Adapter width
 AD* = Adapter length
 Both will vary depending on motor.
 Efficiency is calculated at 100% of the rated torque.

Performance Specifications

Part Number	Ratio ¹	10,000 Hour Life			T peak Nm [in-lb]	20,000 Hour Life			J kg-cm ² [in-lb-sec ² x10 ⁻⁴]	Torsional Stiffness Nm/arc-min [in-lb/arc-min]
		T _r (1000 rpm) Nm [in-lb]	T _r (3000 rpm) Nm [in-lb]	T _r (5000 rpm) Nm [in-lb]		T _r (1000 rpm) Nm [in-lb]	T _r (3000 rpm) Nm [in-lb]	T _r (5000 rpm) Nm [in-lb]		
DTR142D-001	1:1	135 [1194]	123 [1090]	111 [985]	865 [7659]	125 [1103]	114 [1006]	103 [910]	26,3 [232]	23,7 [210]
DTR142D-002	2:1	279 [2474]	255 [2257]	231 [2041]	865 [7659]	258 [2284]	236 [2084]	213 [1885]	13,5 [119]	38,9 [344]
DTR142D-003	3:1	188 [1663]	171 [1518]	155 [1372]	865 [7659]	174 [1536]	158 [1401]	143 [1267]	11,6 [102]	44,1 [390]
DTR142D-004	4:1	135 [1194]	123 [1090]	111 [985]	865 [7659]	125 [1103]	114 [1006]	103 [910]	10,8 [95.1]	46,3 [410]
DTR142D-005P	5:1P	101 [896]	92 [818]	84 [739]	865 [7659]	93 [827]	85 [755]	77 [683]	10,6 [93.3]	47,4 [419]
DTR142D-005T	5:1T	340 [3009]	289 [2559]	281 [2484]	865 [7659]	333 [2944]	267 [2363]	259 [2294]	13,8 [122]	47,4 [419]
DTR142D-006	6:1	329 [2909]	279 [2474]	271 [2402]	865 [7659]	322 [2846]	258 [2284]	251 [2218]	13,8 [122]	31,8 [281]
DTR142D-009	9:1	221 [1956]	188 [1663]	182 [1614]	865 [7659]	216 [1913]	174 [1536]	168 [1491]	11,6 [102]	39,6 [351]
DTR142D-010	10:1	339 [2996]	309 [2735]	279 [2474]	865 [7659]	334 [2958]	296 [2621]	258 [2284]	13,1 [116]	31,6 [280]
DTR142D-012	12:1	159 [1404]	135 [1194]	131 [1159]	865 [7659]	155 [1374]	125 [1103]	121 [1071]	11,1 [97.7]	43,4 [384]
DTR142D-015	15:1	228 [2014]	208 [1839]	188 [1663]	865 [7659]	225 [1989]	199 [1762]	174 [1536]	10,9 [95.9]	45,4 [402]
DTR142D-020	20:1	163 [1446]	149 [1320]	135 [1194]	865 [7659]	161 [1428]	143 [1265]	125 [1103]	10,4 [91.5]	43,3 [383]
DTR142D-025	25:1	123 [1085]	112 [991]	101 [896]	865 [7659]	121 [1071]	107 [949]	93 [827]	10,2 [89.8]	45,3 [401]
DTR142D-030	30:1	233 [2058]	223 [1970]	213 [1882]	865 [7659]	231 [2045]	218 [1932]	205 [1819]	10,6 [93.8]	38,8 [343]
DTR142D-040	40:1	167 [1478]	160 [1415]	153 [1352]	865 [7659]	166 [1469]	157 [1387]	148 [1306]	10,1 [89.4]	42,8 [379]
DTR142D-050	50:1	125 [1109]	120 [1061]	115 [1014]	865 [7659]	125 [1102]	118 [1041]	111 [980]	9,91 [87.6]	45,0 [398]
DTR142D-060	60:1	351 [3105]	346 [3061]	341 [3018]	865 [7659]	350 [3099]	344 [3042]	337 [2986]	13,8 [122]	31,0 [274]
DTR142D-075	75:1	236 [2084]	232 [2049]	228 [2014]	865 [7659]	235 [2079]	230 [2034]	225 [1989]	11,1 [97.9]	39,4 [348]
DTR142D-090	90:1	236 [2087]	233 [2058]	229 [2029]	865 [7659]	235 [2083]	231 [2045]	227 [2008]	11,6 [103]	39,1 [346]
DTR142D-100	100:1	352 [3114]	349 [3088]	346 [3061]	865 [7659]	351 [3110]	348 [3076]	344 [3042]	13,1 [116]	31,3 [278]
DTR142D-120	120:1	169 [1499]	167 [1478]	165 [1457]	865 [7659]	169 [1496]	166 [1469]	163 [1442]	11,1 [98.2]	43,0 [380]
DTR142D-125	125:1	127 [1123]	125 [1104]	123 [1085]	865 [7659]	127 [1120]	124 [1096]	121 [1071]	10,4 [91.7]	45,3 [401]
DTR142D-150	150:1	237 [2093]	235 [2076]	233 [2058]	865 [7659]	236 [2091]	234 [2068]	231 [2045]	10,9 [96.4]	39,3 [348]
DTR142D-200	200:1	353 [3120]	351 [3107]	350 [3094]	865 [7659]	352 [3118]	350 [3101]	349 [3085]	12,9 [114]	30,5 [270]
DTR142D-250	250:1	127 [1128]	126 [1118]	125 [1109]	865 [7659]	127 [1126]	126 [1114]	125 [1102]	10,2 [90.3]	45,2 [400]
DTR142D-300	300:1	237 [2098]	236 [2089]	235 [2080]	865 [7659]	237 [2096]	236 [2085]	234 [2074]	10,7 [94.3]	38,8 [343]
DTR142D-400	400:1	170 [1506]	169 [1500]	169 [1494]	865 [7659]	170 [1505]	169 [1497]	168 [1489]	10,2 [89.8]	42,8 [379]
DTR142D-500	500:1	128 [1130]	127 [1125]	127 [1121]	865 [7659]	128 [1129]	127 [1123]	126 [1117]	9,96 [88.1]	45,0 [398]

Ratio 5P is designed using only PowerTRUE face gearing technology.
 Ratio 5T adds a True Planetary gearing stage for increased torque capacity.
¹ Ratios are exact, higher ratios are also available, consult factory.

T_r = Rated output torque at rated speed for specific hours of life.
 J = Mass moment of inertia reflected to the input shaft (including pinion assembly)
 T_{peak} = Allowable momentary peak torque for emergency stop or heavy shock loading.

Radial and Axial Load Ratings

DTR60D

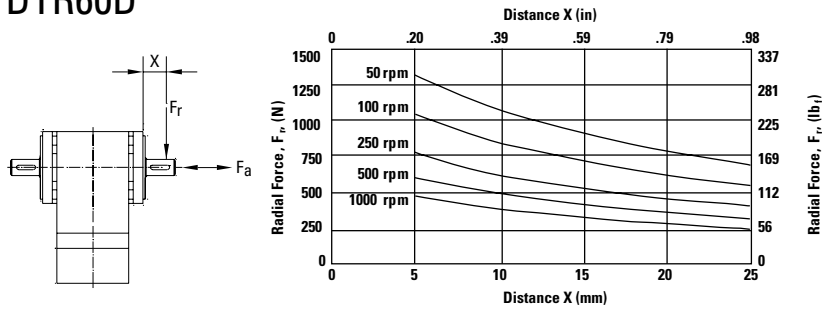

Speed rpm	Axial Load, F_a N [lb _f]
50	2155 [484]
100	1710 [384]
250	1260 [283]
500	1000 [225]
1000	794 [178]

DTR90D

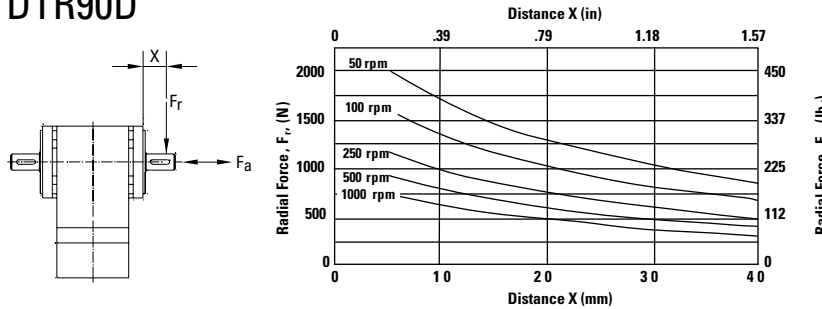

Speed rpm	Axial Load, F_a N [lb _f]
50	3157 [710]
100	2506 [563]
250	1846 [415]
500	1465 [329]
1000	1163 [261]

DTR115D

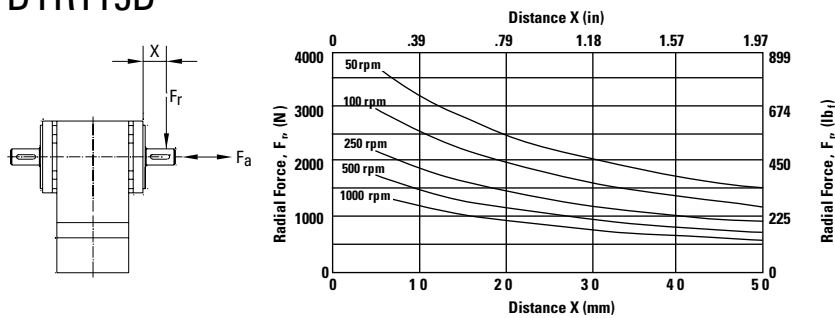

Speed rpm	Axial Load, F_a N [lb _f]
50	5742 [1291]
100	4558 [1025]
250	3358 [755]
500	2665 [599]
1000	2115 [476]

DTR142D

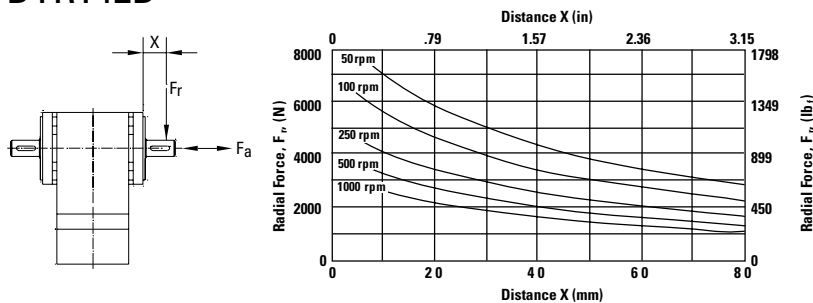

Speed rpm	Axial Load, F_a N [lb _f]
50	11925 [2681]
100	9465 [2128]
250	6974 [1568]
500	5535 [1244]
1000	4393 [988]

These graphs display the allowable radial load at a given distance (X) from the mounting surface based on an L_{10} life of 10,000 hours for the mean output speed n_{mount} , as described on page 10.

ValueTRUE™

True Planetary Gearheads

Ready for Immediate Delivery	
Precision	4 arc-minutes
Frame Sizes	60mm, 75mm, 90mm, 100mm, 115mm, 140mm, 180mm and 220mm
Torque Capacity	up to 2970 Nm
Ratio Availability	4:1 thru 100:1
Mounting System	RediMount™
Both in-line and right angles available	

- ValueTRUE is a new high performance price competitive Gearhead line of Micron True Planetary Gearheads
- Low Cost– 30% less than typical market pricing
- Helical Crowned True Planetary Gearing improved load capacity, lower backlash and smoother & quieter operation compared to non-helical gearheads
- Ultra Precision – 4 arc-mins of backlash
- Drop-In, low cost replacement for most common helical gearheads
- Stainless Steel Output Housing provides rock solid durability, suitable for environmentally sensitive applications



ValueTRUE™

Helical True Planetary™ Gearheads

Part Number	Stages	Backlash (arc-min)	Efficiency	Weight kg [lbs]	Ratio Availability
VT006	1	4	95%	2 [4.4]	4:1, 5:1, 7:1, 10:1
	2	5	90%	2.5 [5.5]	16:1, 20:1, 25:1, 28:1, 35:1, 40:1, 50:1, 70:1, 100:1
VT075	1	4	95%	2.5 [5.5]	4:1, 5:1, 7:1, 10:1
	2	5	90%	3.0 [6.6]	16:1, 20:1, 25:1, 28:1, 35:1, 40:1, 50:1, 70:1, 100:1
VT090	1	4	95%	2.5 [5.5]	4:1, 5:1, 7:1, 10:1
	2	5	90%	3.0 [6.6]	16:1, 20:1, 25:1, 28:1, 35:1, 40:1, 50:1, 70:1, 100:1
VT010	1	4	95%	6 [13]	4:1, 5:1, 7:1, 10:1
	2	5	90%	8 [18]	16:1, 20:1, 25:1, 28:1, 35:1, 40:1, 50:1, 70:1, 100:1
VT115	1	4	95%	6 [13]	4:1, 5:1, 7:1, 10:1
	2	5	90%	8 [18]	16:1, 20:1, 25:1, 28:1, 35:1, 40:1, 50:1, 70:1, 100:1
VT014	1	4	95%	14 [31]	4:1, 5:1, 7:1, 10:1
	2	5	90%	18 [40]	16:1, 20:1, 25:1, 28:1, 35:1, 40:1, 50:1, 70:1, 100:1
VT018	1	4	95%	40 [88]	4:1, 5:1, 7:1, 10:1
	2	5	90%	45 [99]	16:1, 20:1, 25:1, 28:1, 35:1, 40:1, 50:1, 70:1, 100:1
VT022	1	4	95%	74 [162]	4:1, 5:1, 7:1, 10:1
	2	5	90%	95 [209]	16:1, 20:1, 25:1, 28:1, 35:1, 40:1, 50:1, 70:1, 100:1
VTR006	1	5	93%	3 [6.6]	8:1, 10:1, 12:1, 14:1, 15:1, 16:1, 20:1, 25:1, 28:1, 30:1, 35:1, 40:1, 50:1
VTR075	1	5	93%	5.3 [11.1]	8:1, 10:1, 12:1, 14:1, 15:1, 16:1, 20:1, 25:1, 28:1, 30:1, 35:1, 40:1, 50:1
VTR090	1	5	93%	5.3 [11.1]	8:1, 10:1, 12:1, 14:1, 15:1, 16:1, 20:1, 25:1, 28:1, 30:1, 35:1, 40:1, 50:1
VTR010	1	5	93%	12 [26.2]	4:1, 5:1, 8:1, 10:1, 12:1, 14:1, 15:1, 16:1, 20:1, 25:1, 28:1, 30:1, 35:1, 40:1, 50:1
VTR115	1	5	93%	12 [26.2]	4:1, 5:1, 8:1, 10:1, 12:1, 14:1, 15:1, 16:1, 20:1, 25:1, 28:1, 30:1, 35:1, 40:1, 50:1
VTR014	1	5	93%	29 [64]	4:1, 5:1, 8:1, 10:1, 12:1, 14:1, 15:1, 16:1, 20:1, 25:1, 28:1, 30:1, 35:1, 40:1, 50:1
VTR018	1	5	93%	48 [106]	4:1, 5:1, 8:1, 10:1, 12:1, 14:1, 15:1, 16:1, 20:1, 25:1, 28:1, 30:1, 35:1, 40:1, 50:1

All ratios in frame size 60, 75, 100 and 140 are available to ship in 24 hours through the Gearhead Express Program.

- * Efficiency measured at 100% rated torque
- * Backlash is maximum for the life of the gearhead
- * For other ratios, please contact factory

ValueTRUE™

Helical True Planetary™ Gearheads

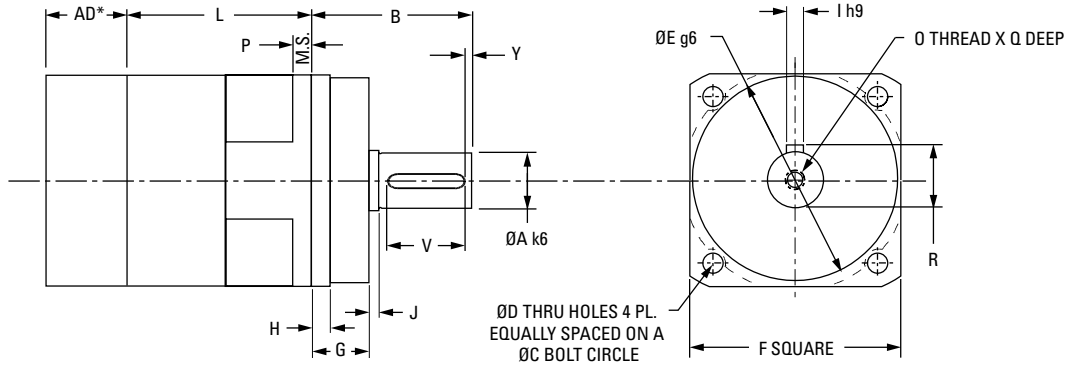

Inline Dimensions

Part Number	F Flange Square mm [in]	A Output Shaft Diameter mm [in]	B Output Shaft Length mm [in]	Y Shaft End Distance mm [in]	V Keyway Length mm [in]	R Keyway Height mm [in]	I Key Square mm [in]	J Shoulder Length mm [in]	E Pilot Diameter mm [in]
VT006	61 [2.40]	16 [0.63]	48 [1.89]	1 [0.04]	25 [0.98]	18 [0.71]	5 [0.20]	1 [0.04]	60 [2.36]
VT075	75 [2.95]	22 [0.86]	56 [2.20]	1,5 [0.06]	32 [1.26]	24,5 [0.97]	6 [0.24]	1 [0.04]	70 [2.75]
VT090	90 [3.54]	22 [0.86]	48 [1.89]	1,5 [0.06]	32 [1.26]	24,5 [0.97]	6 [0.24]	1 [0.04]	80 [1.48]
VT010	101 [3.98]	32 [1.26]	88 [3.46]	3 [0.12]	50 [1.97]	35 [1.38]	10 [0.39]	2 [0.08]	90 [3.54]
VT115*	115 [4.53]	32 [1.26]	72 [2.83]	3 [0.12]	50 [1.97]	35 [1.38]	10 [0.39]	2 [0.08]	110 [4.33]
VT014	141 [5.55]	40 [1.57]	112 [4.41]	5 [0.20]	70 [2.76]	43 [1.69]	12 [0.47]	3 [0.12]	130 [5.11]
VT018	182 [7.17]	55 [2.17]	112 [4.41]	6 [0.24]	70 [2.76]	59 [2.32]	16 [0.63]	3 [0.12]	180 [6.29]
VT022	220 [8.66]	75 [2.95]	143 [5.63]	7 [0.28]	90 [3.54]	79,5 [0.71]	20 [0.78]	3 [0.12]	180 [6.29]

Inline Dimensions (continued)

Part Number	G Pilot Length mm [in]	P Flange Thickness mm [in]	H Effective Pilot Length mm [in]	L Length mm [in]		C Bolt Circle mm [in]	D Bolt Hole mm [in]	O Output Shaft Thread mm [in]	Q Thread Depth mm [in]
				4:1 - 10:1	16:1 - 100:1				
VT006	18 [0.71]	7 [0.28]	7 [0.28]	57 [2.24]	105,4 [4.15]	68 [2.68]	5,6 [0.22]	M5	19 [0.75]
VT075	20 [0.79]	8 [0.31]	7 [0.28]	60 [2.36]	117 [4.60]	85 [3.35]	7 [0.28]	M8	19 [0.75]
VT090	12 [0.47]	10 [0.39]	12 [0.47]	68 [2.67]	125 [4.92]	100 [3.94]	6,6 [0.26]	M8	19 [0.75]
VT010	28 [1.10]	10 [0.39]	12 [0.47]	78 [3.07]	146 [5.74]	120 [4.72]	9 [0.35]	M12	20 [0.80]
VT115*	12 [0.47]	12 [0.47]	12 [0.47]	94 [3.70]	162 [6.37]	130 [5.118]	9 [0.35]	M12	20 [0.80]
VT014	27 [1.06]	13 [0.51]	14 [0.55]	110,5 [4.35]	195 [7.67]	165 [6.50]	11 [0.43]	M12	20 [0.80]
VT018	27 [1.06]	15 [0.59]	13 [0.51]	136 [5.35]	244 [9.60]	215 [8.46]	13,5 [0.53]	M20	42 [1.65]
VT022	35 [1.38]	17 [0.67]	18 [0.71]	131 [5.15]	232 [9.13]	250 [9.84]	17 [0.67]	M20	42 [1.65]

All ratios in frame size 60, 75, 100 and 140 are available to ship in 24 hours through the Gearhead Express Program.

¹ Ratios are exact, higher ratios are also available, consult factory.
 T_r = Rated output torque at rated speed for specific hours of life.
 * Drawing not exactly as shown for VT115

T_{peak} = Allowable momentary peak torque for emergency stop or heavy shock loading.
 J = Mass moment of inertia reflected to the input shaft (including pinion assembly).

ValueTRUE 90™

Helical Right Angle Gearheads

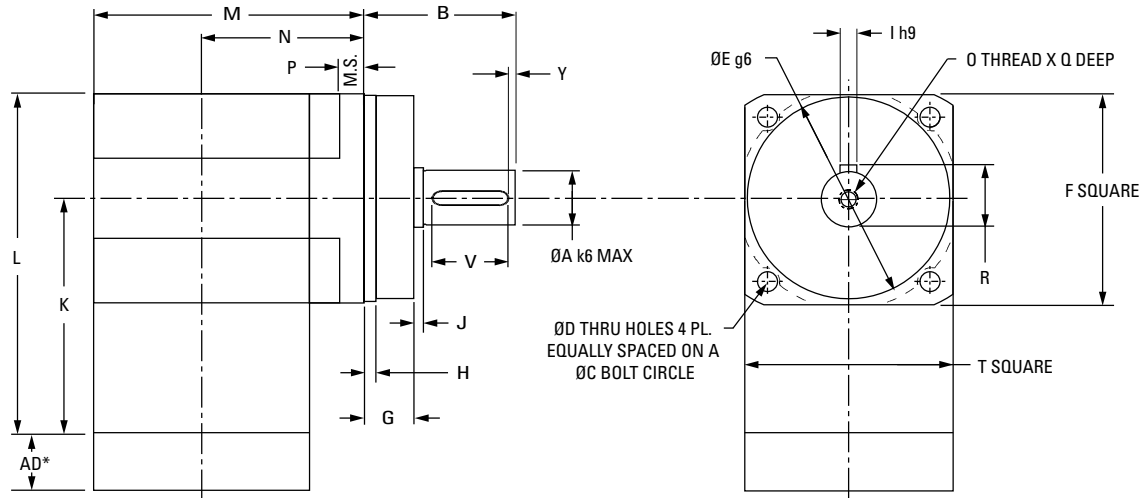

Right Angle Dimensions

Part Number	F Output Flange Square mm [in]	A Output Shaft Diameter mm [in]	B Output Shaft Length mm [in]	Y Shaft End Distance mm [in]	V Keyway Length mm [in]	R Keyway Height mm [in]	I Key Square mm [in]	J Shoulder Length mm [in]	O Output Shaft Thread mm [in]	Q Thread Depth mm [in]	E Pilot Diameter mm [in]	G Pilot Length mm [in]
VTR006	61 [2.40]	16 [0.63]	48 [1.89]	1 [0.04]	25 [0.98]	18 [0.71]	5 [0.20]	1 [0.04]	M5	19 [0.75]	60 [2.36]	18 [0.71]
VTR075	75 [2.95]	22 [0.86]	56 [2.20]	1,5 [0.06]	32 [1.26]	24,5 [0.97]	6 [0.24]	1 [0.04]	M8	19 [0.75]	70 [2.75]	20 [0.79]
VTR090	90 [3.54]	22 [0.86]	48 [1.89]	1,5 [0.06]	32 [1.26]	24,5 [0.97]	6 [0.24]	1 [0.04]	M8	19 [0.75]	80 [1.48]	12 [0.47]
VTR010	101 [3.98]	32 [1.26]	88 [3.46]	3 [0.12]	50 [1.97]	35 [1.38]	10 [0.39]	2 [0.08]	M12	20 [0.80]	90 [3.54]	28 [1.10]
VTR115*	115 [4.53]	32 [1.26]	72 [2.83]	3 [0.12]	50 [1.97]	35 [1.38]	10 [0.39]	2 [0.08]	M12	20 [0.80]	110 [4.33]	24 [0.94]
VTR014	141 [5.55]	40 [1.57]	112 [4.41]	5 [0.20]	70 [2.76]	43 [1.69]	12 [0.47]	3 [0.12]	M12	20 [0.80]	130 [5.11]	27 [1.06]
VTR018	182 [7.17]	55 [2.17]	112 [4.41]	6 [0.24]	70 [2.76]	59 [2.32]	16 [0.63]	3 [0.12]	M20	42 [1.65]	180 [6.29]	27 [1.06]

Right Angle Dimensions (continued)

Part Number	P Flange Thickness mm [in]	H Effective Pilot Length mm [in]	L Length mm [in]	K Distance to Output CL mm [in]	C Bolt Circle mm [in]	D Bolt Hole mm [in]	M Housing Width mm [in]		N Distance to Input CL mm [in]		T Input Flange Square mm [in]
							All other ratios	4:1 & 5:1 only	All other ratios	4:1 & 5:1 only	
VTR006	7 [0.28]	7 [0.28]	109,5 [4.31]	79 [3.11]	68 [2.68]	5,6 [0.22]	95 [3.75]	95 [3.75]	65 [2.55]	65 [2.55]	61 [2.40]
VTR075	8 [0.31]	7 [0.28]	141 [5.55]	103 [4.05]	85 [3.35]	7 [0.28]	114,5 [4.51]	114,5 [4.51]	77 [3.04]	77 [3.04]	75 [2.95]
VTR090	10 [0.39]	12 [0.47]	141 [5.55]	103 [4.05]	100 [3.94]	6,6 [0.26]	122,5 [4.82]	122,5 [4.82]	85 [3.35]	85 [3.35]	75 [2.95]
VTR010	10 [0.39]	12 [0.47]	193 [7.60]	142,5 [5.61]	120 [4.72]	9 [0.35]	149 [5.88]	158 [6.19]	99 [3.89]	107 [4.20]	101 [3.98]
VTR115*	12 [0.47]	12 [0.47]	193 [7.60]	142,5 [5.61]	130 [5.118]	9 [0.35]	165 [6.51]	174 [6.82]	114,8 [4.52]	123 [4.83]	101 [3.98]
VTR014	13 [0.51]	14 [0.55]	231 [9.09]	160 [6.23]	165 [6.50]	11 [0.43]	222 [8.74]	222 [8.74]	151 [5.95]	151 [5.95]	142 [5.59]
VTR018	15 [0.59]	13 [0.51]	319 [12.60]	228 [8.97]	215 [8.46]	13,5 [0.53]	273 [10.76]	301 [11.83]	182 [7.18]	210 [8.25]	182 [7.17]

* Drawing not exactly as shown for VTR115

ValueTRUE™ Helical True Planetary Gearheads

Inline Torque: VT006 - VT010

Performance Specifications

Part Number	Ratio	20000 Hour Life			Tpeak Nm [in-lb]	J kg-cm ² [in-lb-sec ² ×10 ⁻⁴]	Torsional Stiffness Nm/arc-min [in-lb/arc-min]	
		T _r (1000 rpm) Nm [in-lb]	T _r (3000 rpm) Nm [in-lb]	T _r (5000 rpm) Nm [in-lb]				
VT006	VT006-004	4:1	42 [375]	32 [290]	28 [248]	91 [802]	0.20 [1.80]	2.36 [20.9]
	VT006-005	5:1	41 [364]	34 [302]	30 [259]	88 [779]	0.13 [1.16]	2.30 [20.4]
	VT006-007	7:1	40 [347]	36 [319]	32 [276]	84 [743]	0.11 [0.96]	2.18 [19.4]
	VT006-010	10:1	22 [194]	19 [167]	17 [156]	79 [703]	0.10 [0.85]	1.74 [15.4]
	VT006-016	16:1	47 [410]	43 [383]	41 [369]	99 [878]	0.16 [1.44]	2.40 [21.3]
	VT006-020	20:1	47 [416]	44 [42]	42 [375]	100 [887]	0.16 [1.44]	2.36 [20.9]
	VT006-025	25:1	45 [401]	42 [376]	41 [364]	96 [853]	0.16 [1.44]	2.32 [20.5]
	VT006-028	28:1	48 [423]	45 [398]	43 [384]	102 [899]	0.16 [1.44]	2.21 [19.6]
	VT006-035	35:1	46 [408]	43 [384]	42 [127]	97 [864]	0.10 [0.85]	2.29 [20.3]
	VT006-040	40:1	49 [430]	46 [406]	44 [394]	103 [910]	0.10 [0.85]	2.40 [21.3]
	VT006-050	50:1	47 [415]	44 [392]	43 [381]	99 [874]	0.10 [0.85]	2.36 [20.9]
VT006-070	70:1	44 [662]	42 [373]	41 [362]	93 [822]	0.10 [0.85]	2.21 [19.6]	
VT006-100	100:1	29 [256]	25 [224]	23 [211]	86 [766]	0.10 [0.85]	1.83 [16.1]	
VT075	VT075-004	4:1	76 [671]	67 [587]	57 [503]	161 [1423]	0.46 [4.10]	6.30 [55.7]
	VT075-005	5:1	74 [651]	67 [591]	59 [525]	157 [1383]	0.38 [3.40]	6.17 [54.6]
	VT075-007	7:1	70 [621]	64 [569]	61 [541]	149 [1322]	0.31 [2.80]	5.46 [48.3]
	VT075-010	10:1	40 [348]	34 [300]	32 [279]	141 [1254]	0.27 [2.40]	4.01 [35.6]
	VT075-016	16:1	84 [738]	77 [686]	75 [659]	177 [1569]	0.31 [2.80]	6.62 [58.6]
	VT075-020	20:1	85 [747]	79 [698]	76 [671]	179 [1586]	0.31 [2.80]	6.48 [57.3]
	VT075-025	25:1	82 [721]	77 [675]	74 [651]	173 [1528]	0.31 [2.80]	6.36 [56.3]
	VT075-028	28:1	86 [761]	81 [714]	77 [689]	182 [1610]	0.28 [2.50]	5.81 [51.4]
	VT075-035	35:1	83 [734]	78 [690]	76 [667]	175 [1549]	0.16 [1.40]	6.01 [53.2]
	VT075-040	40:1	87 [775]	83 [730]	80 [707]	185 [1632]	0.16 [1.40]	6.63 [58.7]
	VT075-050	50:1	85 [747]	80 [706]	77 [683]	177 [1569]	0.16 [1.40]	6.50 [57.5]
VT075-070	70:1	80 [706]	76 [669]	74 [650]	167 [1475]	0.16 [1.40]	5.83 [51.6]	
VT075-100	100:1	52 [462]	46 [405]	43 [380]	156 [1376]	0.15 [1.30]	4.05 [35.8]	
VT090	VT090-004	4:1	76 [671]	67 [587]	57 [503]	161 [1423]	0.46 [4.10]	6.30 [55.7]
	VT090-005	5:1	74 [651]	67 [591]	59 [525]	157 [1383]	0.38 [3.40]	6.17 [54.6]
	VT090-007	7:1	70 [621]	64 [569]	61 [541]	149 [1322]	0.31 [2.80]	5.46 [48.3]
	VT090-010	10:1	40 [348]	34 [300]	32 [279]	141 [1254]	0.27 [2.40]	4.01 [35.6]
	VT090-016	16:1	84 [738]	77 [686]	75 [659]	177 [1569]	0.31 [2.80]	6.62 [58.6]
	VT090-020	20:1	85 [747]	79 [698]	76 [671]	179 [1586]	0.31 [2.80]	6.48 [57.3]
	VT090-025	25:1	82 [721]	77 [675]	74 [651]	173 [1528]	0.31 [2.80]	6.36 [56.3]
	VT090-028	28:1	86 [761]	81 [714]	77 [689]	182 [1610]	0.28 [2.50]	5.81 [51.4]
	VT090-035	35:1	83 [734]	78 [690]	76 [667]	175 [1549]	0.16 [1.40]	6.01 [53.2]
	VT090-040	40:1	87 [775]	83 [730]	80 [707]	185 [1632]	0.16 [1.40]	6.63 [58.7]
	VT090-050	50:1	85 [747]	80 [706]	77 [683]	177 [1569]	0.16 [1.40]	6.50 [57.5]
VT090-070	70:1	80 [706]	76 [669]	74 [650]	167 [1475]	0.16 [1.40]	5.83 [51.6]	
VT090-100	100:1	52 [462]	46 [405]	43 [380]	156 [1376]	0.15 [1.30]	4.05 [35.8]	
VT010	VT010-004	4:1	221 [1954]	158 [1405]	136 [1206]	463 [4093]	1.58 [14.00]	23.1 [204]
	VT010-005	5:1	216 [1908]	166 [1465]	142 [1257]	451 [3991]	1.36 [12.00]	20.5 [182]
	VT010-007	7:1	206 [1825]	176 [1562]	151 [1340]	433 [3830]	0.97 [8.60]	19.0 [168]
	VT010-010	10:1	115 [1016]	99 [872]	92 [808]	411 [3640]	0.90 [8.00]	13.0 [115]
	VT010-016	16:1	246 [2174]	227 [2010]	206 [1827]	518 [4577]	1.10 [9.70]	24.6 [218]
	VT010-020	20:1	249 [2205]	231 [2046]	221 [1954]	524 [4637]	1.10 [9.70]	21.9 [194]
	VT010-025	25:1	241 [2131]	224 [1985]	216 [1908]	506 [4477]	1.10 [9.70]	21.9 [194]
	VT010-028	28:1	254 [2248]	237 [2098]	228 [2018]	533 [4718]	0.94 [8.30]	19.0 [168]
	VT010-035	35:1	246 [2172]	230 [2033]	221 [1959]	514 [4549]	0.79 [7.00]	18.8 [167]
	VT010-040	40:1	259 [2291]	243 [2149]	234 [2075]	542 [4794]	0.79 [7.00]	24.7 [219]
	VT010-050	50:1	250 [2212]	235 [2081]	228 [2012]	521 [4615]	0.78 [6.90]	21.7 [192]
VT010-070	70:1	237 [2094]	223 [1977]	217 [1916]	491 [4349]	0.78 [6.90]	19.0 [168]	
VT010-100	100:1	153 [1354]	134 [1185]	126 [1112]	459 [4059]	0.78 [6.90]	15.5 [137]	

All ratios in frame size 60, 75, 100 and 140 are available to ship in 24 hours through the Gearhead Express Program.

ValueTRUE™ Helical True Planetary Gearheads

Inline Torque: VT115 - VT022

Performance Specifications

Part Number	Ratio	20000 Hour Life			Tpeak Nm [in-lb]	J kg-cm ² [in-lb-sec ² x10 ⁻⁴]	Torsional Stiffness Nm/arc-min [in-lb/arc-min]	
		T _r (1000 rpm) Nm [in-lb]	T _r (3000 rpm) Nm [in-lb]	T _r (5000 rpm) Nm [in-lb]				
VT115	VT115-004	4:1	221 [1954]	158 [1405]	136 [1206]	463 [4093]	1.58 [14.00]	23.1 [204]
	VT115-005	5:1	216 [1908]	166 [1465]	142 [1257]	451 [3991]	1.36 [12.00]	20.5 [182]
	VT115-007	7:1	206 [1825]	176 [1562]	151 [1340]	433 [3830]	0.97 [8.60]	19.0 [168]
	VT115-010	10:1	115 [1016]	99 [872]	92 [808]	411 [3640]	0.90 [8.00]	13.0 [115]
	VT115-016	16:1	246 [2174]	227 [2010]	206 [1827]	518 [4577]	1.10 [9.70]	24.6 [218]
	VT115-020	20:1	249 [2205]	231 [2046]	221 [1954]	524 [4637]	1.10 [9.70]	21.9 [194]
	VT115-025	25:1	241 [2131]	224 [1985]	216 [1908]	506 [4477]	1.10 [9.70]	21.9 [194]
	VT115-028	28:1	254 [2248]	237 [2098]	228 [2018]	533 [4718]	0.94 [8.30]	19.0 [168]
	VT115-035	35:1	246 [2172]	230 [2033]	221 [1959]	514 [4549]	0.79 [7.00]	18.8 [167]
	VT115-040	40:1	259 [2291]	243 [2149]	234 [2075]	542 [4794]	0.79 [7.00]	24.7 [219]
VT014	VT014-004	4:1	518 [4583]	387 [3427]	332 [2940]	1066 [9431]	6.51 [57.60]	49.5 [438]
	VT014-005	5:1	504 [4459]	403 [3571]	347 [3064]	1040 [9206]	5.02 [44.40]	45.9 [407]
	VT014-007	7:1	483 [4274]	430 [3809]	369 [3268]	1002 [8866]	3.80 [33.60]	42.3 [378]
	VT014-010	10:1	275 [2426]	235 [2075]	217 [1919]	956 [8459]	3.39 [30.00]	31.5 [280]
	VT014-016	16:1	579 [5119]	532 [4704]	503 [4456]	1206 [10674]	4.21 [37.20]	52.2 [463]
	VT014-020	20:1	587 [5195]	542 [4795]	518 [4583]	1224 [10832]	4.07 [36.00]	48.6 [431]
	VT014-025	25:1	567 [5021]	526 [4654]	504 [4459]	1183 [10463]	4.07 [36.00]	48.6 [431]
	VT014-028	28:1	599 [5303]	556 [4926]	534 [4725]	1248 [11047]	3.53 [31.20]	42.3 [375]
	VT014-035	35:1	579 [5122]	539 [4774]	518 [4589]	1204 [10653]	2.99 [26.40]	39.6 [352]
	VT014-040	40:1	612 [5413]	572 [5055]	550 [4867]	1271 [11248]	2.99 [26.40]	52.2 [461]
VT018	VT018-004	4:1	1203 [10649]	866 [7658]	743 [6570]	2242 [21609]	25.90 [229.00]	137.7 [1222]
	VT018-005	5:1	1174 [10385]	902 [7981]	774 [6847]	2389 [21143]	20.00 [177.00]	135 [1197]
	VT018-007	7:1	1128 [9878]	962 [8512]	825 [7303]	2309 [20429]	14.60 [129.00]	120.6 [1067]
	VT018-010	10:1	645 [5710]	550 [4864]	507 [4486]	2210 [19561]	13.00 [115.00]	90.9 [804]
	VT018-016	16:1	1356 [12005]	1238 [10963]	1125 [9959]	2800 [24779]	16.10 [142.00]	144.9 [1286]
	VT018-020	20:1	1378 [12194]	1265 [11191]	1203 [10649]	2846 [25187]	15.60 [138.00]	140.4 [1244]
	VT018-025	25:1	1333 [11799]	1229 [10877]	1174 [10385]	2754 [24370]	15.60 [138.00]	117.9 [1044]
	VT018-028	28:1	1409 [12466]	1301 [11518]	1245 [11013]	2910 [25751]	13.50 [119.00]	124.2 [1103]
	VT018-035	35:1	1362 [120490]	1263 [11178]	1211 [10714]	2810 [24870]	11.40 [101.00]	111.6 [988]
	VT018-040	40:1	1439 [12739]	1338 [11846]	1285 [11371]	2970 [2611]	11.40 [101.00]	144.9 [1286]
VT022	VT022-004	4:1	1815 [16065]	1306 [11554]	1121 [9913]	4180 [36986]	87.00 [7.70]	386 [3414]
	VT022-005	5:1	1892 [16740]	1360 [12038]	1167 [10328]	4093 [36225]	73.40 [6.50]	372 [3295]
	VT022-007	7:1	1838 [16268]	1452 [12844]	1245 [11019]	3933 [34804]	62.60 [5.55]	326 [2891]
	VT022-010	10:1	1050 [9293]	893 [8097]	823 [7277]	3871 [34254]	56.90 [5.04]	227 [2012]
	VT022-016	16:1	2218 [19625]	1979 [17513]	1697 [15025]	4722 [41793]	87.30 [7.73]	392 [3472]
	VT022-020	20:1	2254 [19948]	2062 [18246]	1815 [16065]	4791 [42396]	73.60 [6.52]	392 [3470]
	VT022-025	25:1	2184 [19332]	2009 [17781]	1892 [16745]	4636 [41025]	73.10 [6.47]	376 [3329]
	VT022-028	28:1	2304 [20394]	2125 [18803]	2008 [17528]	4884 [43224]	62.70 [5.55]	391 [3469]
	VT022-035	35:1	2233 [19765]	2067 [18294]	1976 [17494]	4719 [41757]	62.50 [5.53]	376 [3328]
	VT022-040	40:1	2357 [20864]	2188 [19359]	2095 [18542]	4972 [43999]	57.20 [5.06]	391 [3466]
VT022	VT022-050	50:1	2282 [20199]	2125 [18808]	2040 [18056]	4795 [42440]	57.10 [5.05]	376 [3326]
	VT022-070	70:1	2165 [19159]	2026 [17930]	1951 [17270]	4523 [40023]	57.00 [5.04]	329 [2903]
	VT022-100	100:1	1414 [12512]	1232 [10904]	1155 [10220]	4367 [38647]	56.90 [5.04]	228 [2014]

All ratios in frame size 60, 75, 100 and 140 are available to ship in 24 hours through the Gearhead Express Program.

ValueTRUE™ Helical Right Angle Gearheads

Right Angle Torque: VTR006 - VTR075

Performance Specifications

Part Number	Ratio	20000 Hour Life			T _{peak} Nm [in-lb]	J kg-cm ² [in-lb-sec ² ×10 ⁻⁴]	Torsional Stiffness Nm/arc-min [in-lb/arc-min]	
		T _r (1000 rpm) Nm [in-lb]	T _r (3000 rpm) Nm [in-lb]	T _r (5000 rpm) Nm [in-lb]				
VTR006	VTR006-008	8:1	44 [390]	41 [358]	34 [303]	95 [844]	0.50 [4.43]	1.89 [16.7]
	VTR006-010	10:1	43 [382]	40 [350]	36 [319]	92 [812]	0.49 [4.34]	1.62 [14.3]
	VTR006-012	12:1	41 [358]	37 [327]	33 [295]	98 [868]	0.39 [3.45]	1.80 [15.9]
	VTR006-014	14:1	41 [358]	38 [335]	37 [327]	87 [773]	0.49 [4.34]	2.16 [19.1]
	VTR006-015	15:1	44 [390]	41 [366]	40 [350]	95 [836]	0.39 [3.45]	2.16 [19.1]
	VTR006-016	16:1	30 [263]	27 [239]	24 [215]	99 [876]	0.39 [3.45]	2.16 [19.1]
	VTR006-020	20:1	37 [327]	34 [303]	31 [271]	95 [844]	0.39 [3.45]	2.16 [19.1]
	VTR006-025	25:1	31 [271]	28 [247]	25 [223]	96 [852]	0.38 [3.36]	2.07 [18.3]
	VTR006-028	28:1	42 [374]	40 [350]	39 [342]	90 [797]	0.39 [3.45]	1.98 [18.3]
	VTR006-030	30:1	25 [223]	22 [191]	21 [183]	84 [741]	0.42 [3.72]	2.07 [18.3]
	VTR006-035	35:1	43 [382]	40 [350]	35 [311]	91 [804]	0.38 [3.36]	2.07 [18.3]
	VTR006-040	40:1	26 [231]	23 [199]	22 [191]	85 [749]	0.39 [3.45]	2.16 [19.1]
VTR006-050	50:1	27 [239]	23 [207]	22 [191]	85 [749]	0.38 [3.36]	2.16 [19.1]	
VTR075	VTR075-008	8:1	80 [709]	73 [645]	70 [621]	170 [1505]	1.90 [16.81]	4.23 [37.4]
	VTR075-010	10:1	77 [685]	71 [629]	68 [605]	165 [1458]	1.90 [16.81]	3.69 [32.7]
	VTR075-012	12:1	82 [725]	76 [669]	73 [645]	175 [1545]	1.50 [13.28]	4.14 [36.6]
	VTR075-014	14:1	74 [653]	68 [605]	66 [581]	157 [1386]	1.90 [16.81]	5.94 [52.6]
	VTR075-015	15:1	79 [701]	74 [653]	70 [621]	168 [1489]	1.50 [13.28]	6.03 [53.4]
	VTR075-016	16:1	84 [741]	77 [685]	75 [661]	177 [1569]	1.50 [13.28]	6.03 [53.4]
	VTR075-020	20:1	80 [709]	75 [661]	72 [637]	171 [1513]	1.50 [13.28]	5.85 [51.8]
	VTR075-025	25:1	82 [725]	77 [677]	72 [637]	173 [1529]	1.50 [13.28]	5.76 [51.0]
	VTR075-028	28:1	77 [677]	72 [637]	69 [613]	161 [1426]	1.50 [13.28]	5.31 [47.0]
	VTR075-030	30:1	45 [398]	40 [350]	37 [327]	149 [1322]	1.60 [14.16]	5.67 [47.0]
	VTR075-035	35:1	77 [685]	73 [645]	70 [621]	163 [1442]	1.50 [13.28]	5.67 [50.2]
	VTR075-040	40:1	47 [414]	41 [358]	38 [335]	151 [1338]	1.50 [13.28]	6.03 [53.4]
VTR075-050	50:1	48 [422]	42 [374]	40 [350]	153 [1354]	1.50 [13.28]	5.94 [52.6]	

¹ Ratios are exact, higher ratios are also available, consult factory.
T_r = Rated output torque at rated speed for specific hours of life.

T_{peak} = Allowable momentary peak torque for emergency stop or heavy shock loading.
J = Mass moment of inertia reflected to the input shaft (including pinion assembly).

ValueTRUE™ Helical Right Angle Gearheads

Right Angle Torque: VTR090 - VTR010

Performance Specifications

Part Number	Ratio	20000 Hour Life			T _{peak} Nm [in-lb]	J kg-cm ² [in-lb-sec ² ×10 ⁻⁴]	Torsional Stiffness Nm/arc-min [in-lb/arc-min]	
		T _r (1000 rpm) Nm [in-lb]	T _r (3000 rpm) Nm [in-lb]	T _r (5000 rpm) Nm [in-lb]				
VTR090	VTR090-008	8:1	80 [709]	73 [345]	70 [621]	170 [1505]	1.90 [16.81]	4.23 [37.4]
	VTR090-010	10:1	77 [685]	71 [629]	68 [605]	165 [1458]	1.90 [16.81]	3.69 [32.7]
	VTR090-012	12:1	82 [725]	76 [669]	73 [645]	175 [1545]	1.50 [13.28]	4.14 [36.6]
	VTR090-014	14:1	74 [653]	68 [605]	66 [581]	157 [1386]	1.90 [16.81]	5.94 [52.6]
	VTR090-015	15:1	79 [701]	74 [653]	70 [621]	168 [1489]	1.50 [13.28]	6.03 [53.4]
	VTR090-016	16:1	84 [741]	77 [685]	75 [661]	177 [1569]	1.50 [13.28]	6.03 [53.4]
	VTR090-020	20:1	80 [709]	75 [661]	72 [637]	171 [1513]	1.50 [13.28]	5.85 [51.8]
	VTR090-025	25:1	82 [725]	77 [677]	72 [637]	173 [1529]	1.50 [13.28]	5.76 [51.0]
	VTR090-028	28:1	77 [677]	72 [637]	69 [613]	161 [1426]	1.50 [13.28]	5.31 [47.0]
	VTR090-030	30:1	45 [398]	40 [350]	37 [327]	149 [1322]	1.60 [14.16]	5.67 [50.2]
	VTR090-035	35:1	77 [685]	73 [645]	70 [621]	163 [1442]	1.50 [13.28]	5.67 [50.2]
	VTR090-040	40:1	47 [414]	41 [358]	38 [335]	151 [1338]	1.50 [13.28]	6.03 [53.4]
VTR090-050	50:1	48 [422]	42 [374]	40 [350]	153 [1354]	1.50 [13.28]	5.94 [52.6]	
VTR010	VTR010-004	4:1	234 [2071]	195 [1728]	167 [1673]	492 [4357]	3.30 [29.20]	14.94 [132.2]
	VTR010-005	5:1	228 [2015]	203 [1800]	175 [1649]	478 [4229]	3.30 [29.20]	11.79 [104.3]
	VTR010-008	8:1	234 [2071]	195 [1728]	167 [1673]	492 [4357]	3.30 [29.20]	14.94 [132.2]
	VTR010-010	10:1	228 [2015]	203 [1800]	175 [1649]	478 [4229]	3.30 [29.20]	11.79 [104.3]
	VTR010-012	12:1	243 [2151]	221 [1951]	189 [1744]	508 [4492]	2.60 [23.01]	16.92 [149.7]
	VTR010-014	14:1	217 [1920]	200 [1768]	186 [1649]	455 [4030]	3.30 [29.20]	20.79 [184.0]
	VTR010-015	15:1	233 [2063]	216 [1912]	197 [1744]	491 [4349]	2.50 [22.12]	21.87 [193.5]
	VTR010-016	16:1	225 [1991]	205 [1816]	185 [1641]	518 [4580]	2.60 [23.01]	22.32 [197.5]
	VTR010-020	20:1	238 [2103]	221 [1951]	212 [1872]	500 [4421]	2.60 [23.01]	19.89 [176.0]
	VTR010-025	25:1	211 [1864]	193 [1705]	174 [1532]	506 [4476]	2.50 [22.12]	19.89 [176.0]
	VTR010-028	28:1	226 [1999]	211 [1854]	203 [1792]	473 [4190]	2.60 [23.01]	17.28 [152.9]
	VTR010-030	30:1	132 [1171]	115 [1020]	107 [948]	439 [3887]	2.80 [24.78]	17.19 [152.9]
	VTR010-035	35:1	229 [2023]	214 [1896]	206 [1824]	479 [4237]	2.50 [22.12]	17.10 [152.1]
	VTR010-040	40:1	137 [1211]	119 [1051]	112 [988]	445 [3935]	2.60 [23.01]	22.41 [198.3]
	VTR010-050	50:1	140 [1243]	122 [1083]	115 [1020]	448 [3967]	2.50 [22.12]	19.71 [174.4]

¹ Ratios are exact, higher ratios are also available, consult factory.
T_r = Rated output torque at rated speed for specific hours of life.

T_{peak} = Allowable momentary peak torque for emergency stop or heavy shock loading.
J = Mass moment of inertia reflected to the input shaft (including pinion assembly).

ValueTRUE™ Helical Right Angle Gearheads

Right Angle Torque: VTR115, VTR014, VTR018

Performance Specifications

Part Number	Ratio	20000 Hour Life			T _{peak} Nm [in-lb]	J kg-cm ² [in-lb-sec ² ×10 ⁻⁴]	Torsional Stiffness Nm/arc-min [in-lb/arc-min]	
		T _r (1000 rpm) Nm [in-lb]	T _r (3000 rpm) Nm [in-lb]	T _r (5000 rpm) Nm [in-lb]				
VTR115	VTR115-004	4:1	234 [2071]	195 [1728]	167 [1481]	492 [4357]	3.30 [29.20]	14.94 [132.2]
	VTR115-005	5:1	228 [2015]	203 [1800]	175 [1545]	478 [4229]	3.30 [29.20]	11.79 [104.3]
	VTR115-008	8:1	234 [2071]	195 [1728]	167 [1481]	492 [4357]	3.30 [29.20]	14.94 [132.2]
	VTR115-010	10:1	228 [2015]	203 [1800]	175 [1545]	478 [4229]	3.30 [29.20]	11.79 [104.3]
	VTR115-012	12:1	243 [2151]	221 [1951]	189 [1673]	508 [4492]	2.60 [23.01]	16.92 [149.7]
	VTR115-014	14:1	217 [1920]	200 [1768]	186 [1649]	455 [4030]	3.30 [29.20]	20.79 [184.0]
	VTR115-015	15:1	233 [2063]	216 [1912]	197 [1744]	491 [4349]	2.50 [22.12]	21.87 [193.5]
	VTR115-016	16:1	225 [1991]	205 [1816]	185 [1641]	518 [4580]	2.60 [23.01]	22.32 [197.3]
	VTR115-020	20:1	238 [2103]	221 [1951]	212 [1872]	500 [4421]	2.60 [23.01]	19.89 [176.0]
	VTR115-025	25:1	211 [1864]	193 [1705]	174 [1537]	506 [4476]	2.50 [22.12]	19.89 [176.0]
	VTR115-028	28:1	226 [1999]	211 [1864]	203 [1792]	473 [4190]	2.60 [23.01]	17.28 [152.9]
	VTR115-030	30:1	132 [1171]	115 [1020]	107 [948]	439 [3887]	2.80 [24.78]	17.19 [152.1]
	VTR115-035	35:1	229 [2023]	214 [1896]	203 [1824]	479 [4237]	2.50 [22.12]	17.10 [151.3]
	VTR115-040	40:1	137 [1211]	119 [1051]	112 [988]	445 [3935]	2.60 [23.01]	22.41 [198.3]
	VTR115-050	50:1	140 [1243]	122 [1083]	115 [1020]	448 [3967]	2.50 [22.12]	19.71 [174.4]
VTR014	VTR014-004	4:1	550 [4867]	477 [4221]	409 [3616]	1142 [10108]	16.00 [141.60]	33.03 [292.0]
	VTR014-005	5:1	534 [4723]	485 [4293]	427 [3775]	1110 [9821]	16.00 [141.60]	28.71 [254.0]
	VTR014-008	8:1	550 [4867]	477 [4221]	409 [3616]	1142 [10108]	16.00 [141.60]	33.03 [292.0]
	VTR014-010	10:1	534 [4723]	485 [4293]	427 [3775]	1110 [9821]	16.00 [141.60]	28.71 [254.0]
	VTR014-012	12:1	567 [5018]	518 [4580]	462 [4086]	1182 [10458]	13.00 [115.05]	19.89 [176.0]
	VTR014-014	14:1	509 [4500]	466 [4126]	444 [3927]	1061 [9391]	16.00 [141.60]	46.44 [411.0]
	VTR014-015	15:1	549 [4859]	504 [4460]	480 [4245]	1145 [10131]	12.00 [106.20]	46.53 [412.0]
	VTR014-016	16:1	525 [4644]	479 [4237]	433 [3831]	1206 [10673]	13.00 [115.05]	47.52 [421.0]
	VTR014-020	20:1	560 [4954]	517 [4572]	493 [4365]	1166 [10323]	13.00 [115.05]	44.28 [392.0]
	VTR014-025	25:1	532 [4707]	494 [4373]	474 [4198]	1183 [10466]	13.00 [115.05]	38.52 [341.0]
	VTR014-028	28:1	532 [4707]	494 [4373]	474 [4198]	1108 [9805]	13.00 [115.05]	38.52 [341.0]
	VTR014-030	30:1	317 [2804]	275 [2429]	256 [2262]	1029 [9104]	14.00 [123.90]	40.23 [356.0]
	VTR014-035	35:1	539 [4771]	502 [4444]	483 [4277]	1121 [9924]	12.00 [106.20]	36.18 [320.0]
	VTR014-040	40:1	328 [2899]	285 [2525]	266 [2350]	1043 [9231]	13.00 [115.05]	47.34 [419.0]
	VTR014-050	50:1	338 [2987]	293 [2597]	275 [2429]	1054 [9327]	12.00 [106.20]	44.28 [392.0]
VTR018	VTR018-004	4:1	1285 [11374]	1066 [9431]	914 [8092]	2636 [23329]	45 [398]	102 [900]
	VTR018-005	5:1	1247 [11039]	1111 [9829]	952 [8427]	2566 [22708]	45 [398]	83 [733]
	VTR018-008	8:1	1285 [11374]	1066 [9431]	914 [8092]	2636 [23329]	45 [398]	102 [900]
	VTR018-010	10:1	1247 [11039]	1111 [9829]	952 [8427]	2566 [22708]	45 [398]	83 [733]
	VTR018-012	12:1	1328 [11748]	1203 [10649]	1032 [9136]	2736 [24214]	36 [319]	57 [502]
	VTR018-014	14:1	1193 [10554]	1085 [9606]	1016 [8992]	2460 [21768]	45 [398]	100 [884]
	VTR018-015	15:1	1287 [11390]	1174 [10386]	1076 [9518]	2655 [23497]	35 [310]	130 [1147]
	VTR018-016	16:1	1199 [10609]	1094 [9685]	989 [8754]	2800 [24779]	36 [319]	132 [1171]
	VTR018-020	20:1	1314 [11629]	1205 [10665]	1148 [10155]	2713 [24007]	36 [319]	128 [1131]
	VTR018-025	25:1	1054 [9327]	962 [8515]	870 [7702]	2754 [24373]	35 [310]	107 [948]
	VTR018-028	28:1	1251 [11071]	1156 [10227]	1105 [9781]	2583 [22860]	36 [319]	113 [1004]
	VTR018-030	30:1	747 [6611]	645 [5711]	600 [5313]	2399 [21227]	38 [336]	102 [900]
	VTR018-035	35:1	1268 [11223]	1176 [10410]	1128 [9980]	2617 [23162]	35 [310]	102 [900]
	VTR018-040	40:1	775 [6858]	671 [5942]	626 [5536]	2437 [21569]	36 [319]	132 [1171]
	VTR018-050	50:1	338 [2987]	691 [6117]	645 [5711]	2465 [21816]	35 [310]	128 [1131]

¹ Ratios are exact, higher ratios are also available, consult factory.
T_r = Rated output torque at rated speed for specific hours of life.

T_{peak} = Allowable momentary peak torque for emergency stop or heavy shock loading.
J = Mass moment of inertia reflected to the input shaft (including pinion assembly).

Radial and Axial Load Ratings

VT006

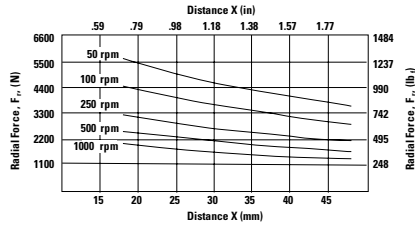
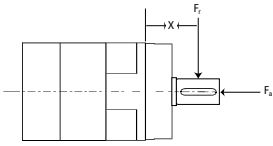

Speed rpm	Axial Load, F_a N [lb.]
50	7198 [1618]
100	5710 [1284]
250	4208 [946]
500	3342 [751]
1000	2652 [596]

VT075 and VT090

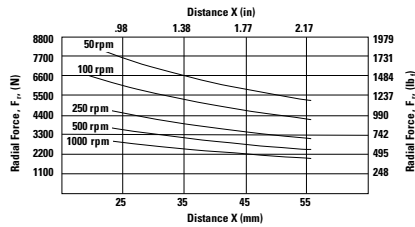
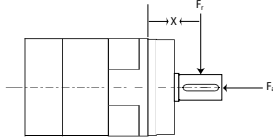

Speed rpm	Axial Load, F_a N [lb.]
50	9903 [2227]
100	7863 [1768]
250	5793 [1303]
500	4599 [1034]
1000	3650 [821]

VT010 and VT115

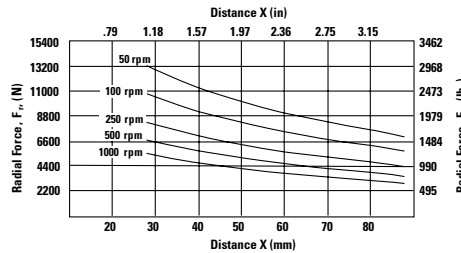
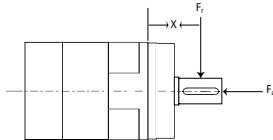

Speed rpm	Axial Load, F_a N [lb.]
50	13,675 [3075]
100	11,107 [2497]
250	8435 [1897]
500	6855 [1542]
1000	5568 [1252]

VT014

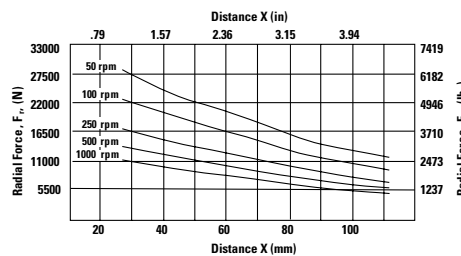
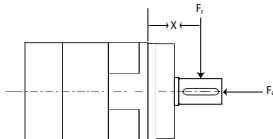

Speed rpm	Axial Load, F_a N [lb.]
50	25,374 [5705]
100	20,609 [4633]
250	15,657 [3520]
500	12,716 [2859]
1000	10,329 [2322]

VT018

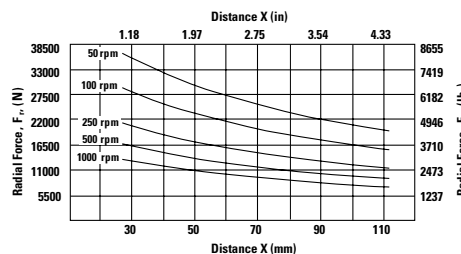
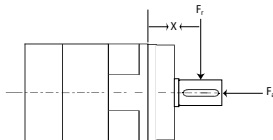

Speed rpm	Axial Load, F_a N [lb.]
50	34,538 [7765]
100	27,414 [6163]
250	20,197 [4541]
500	16,034 [3605]
1000	12,726 [2861]

VT022

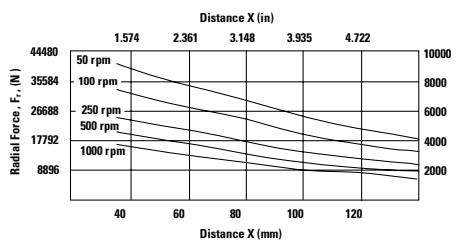
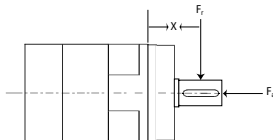

Speed rpm	Axial Load, F_a N [lb.]
50	32,351 [3655]
100	26,277 [2969]
250	19,962 [2256]
500	16,214 [1832]

These graphs display the allowable radial load at a given distance (X) from the mounting surface based on an L_{10} life of 10,000 hours for the mean output speed n_{mout} , as described on page 10,

Radial and Axial Load Ratings

VTR006

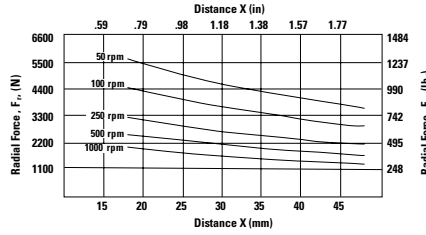
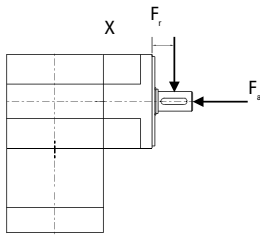

Speed rpm	Axial Load, F_a N [lb _f]
50	7198 [1618]
100	5710 [1284]
250	4208 [946]
500	3342 [751]
1000	2652 [596]

VTR075 and VTR090

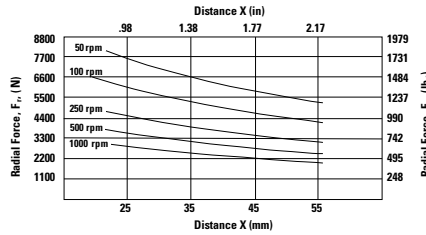
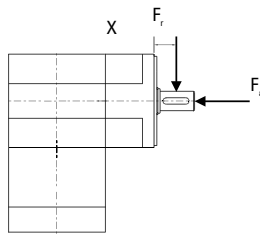

Speed rpm	Axial Load, F_a N [lb _f]
50	9903 [2227]
100	7863 [1768]
250	5793 [1303]
500	4599 [1034]
1000	3650 [821]

VTR010 and VTR115

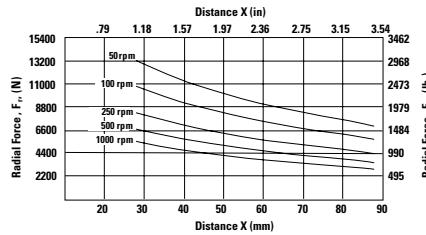
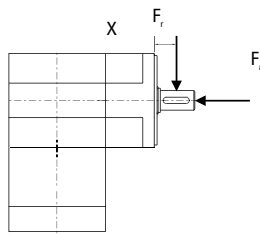

Speed rpm	Axial Load, F_a N [lb _f]
50	13,675 [3075]
100	11,107 [2497]
250	8435 [1897]
500	6855 [1542]
1000	5568 [1252]

VTR014

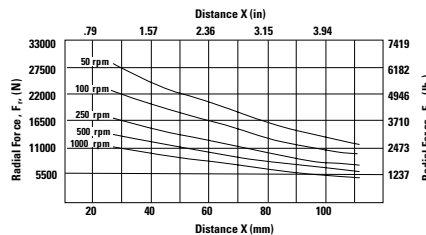
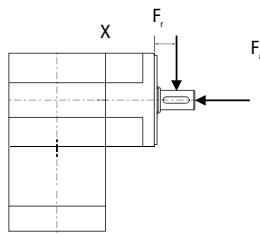

Speed rpm	Axial Load, F_a N [lb _f]
50	25,374 [5705]
100	20,609 [4633]
250	15,657 [3520]
500	12,716 [2859]
1000	10,329 [2322]

VTR018

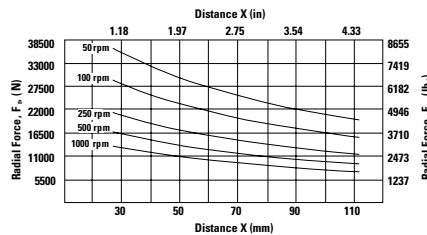
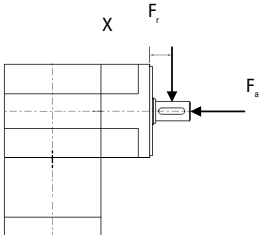

Speed rpm	Axial Load, F_a N [lb _f]
50	34,538 [7765]
100	27,414 [6163]
250	20,197 [4541]
500	16,034 [3605]
1000	12,726 [2861]

These graphs display the allowable radial load at a given distance (X) from the mounting surface based on an L₁₀ life of 10,000 hours for the mean output speed n_{mout} , as described on page 10,



UltraTRUE™

Helical True Planetary™ Gearheads

Ready for Immediate Delivery	
Precision	4 arc-minutes
Frame Sizes	60mm, 75mm, 90mm, 100mm, 115mm, 140mm, 180mm and 220mm
Torque Capacity	up to 3300 Nm
Ratio Availability	4:1 thru 100:1
Radial load capacity	up to 37910 N
Mounting System	RediMount™

- ① **Tapered roller bearings**
provide high axial and radial load carrying capacity
- ② **Helical crowned**
HRC 55-60 steel gears
provide higher torque capacity and smoother operation
- ③ **Sealed deep groove ball bearing**
provides high radial load carrying capability
- ④ **RediMount™ system**
provides error-free motor installation
- ⑤ **Single piece output**
integrated output housing and internal gear
- ⑥ **Anodized aluminum housing**
reduces weight and prevents corrosion

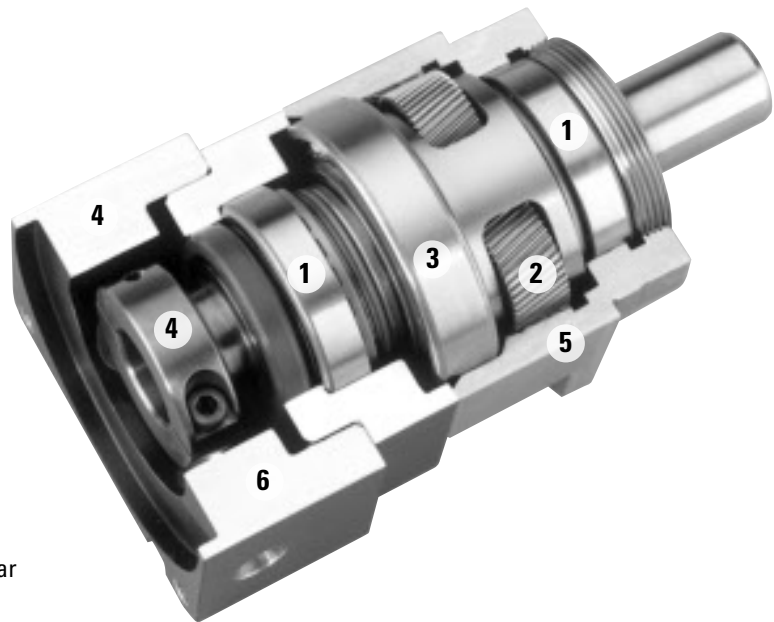

Micron True Planetary™ Gearheads shipped within 24 hours!



Need it fast? Go to the back cover of the catalog for details.

UltraTRUE™ Size 60

Helical True Planetary™ Gearheads

Metric

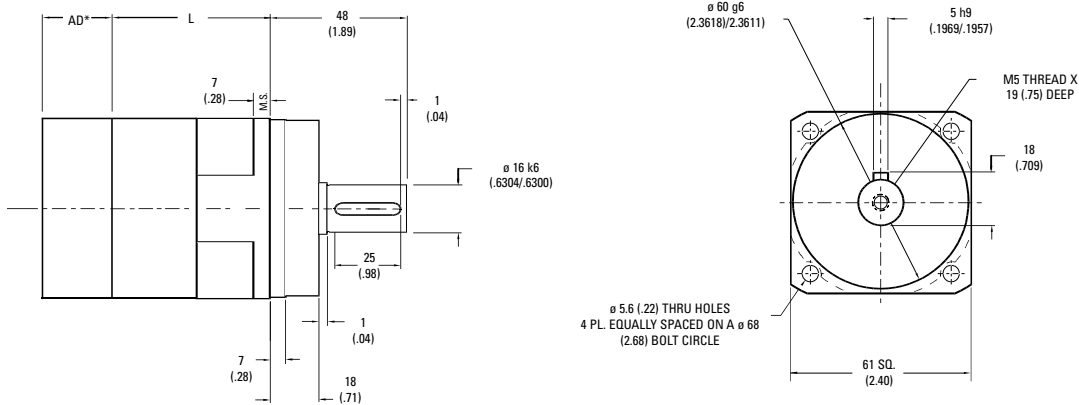

Ratio ¹	Dimension 'L' mm [in]	Backlash [arc-min]	Weight kg [lb]	Efficiency
4:1 to 10:1	57 [2.25]	4 max	2 [4.4]	95%
16:1 to 100:1	105,4 [4.15]	5 max	2.5 [5.5]	90%

All dimensions are: mm (inch)
 AD** = Adapter length
 Adapter length will vary depending on motor.
 M.S = Mounting Surface
 Efficiency is calculated at 100% of the rated torque.

Performance Specifications

Part Number	Ratio ¹	10,000 Hour Life			T peak Nm [in-lb]	20,000 Hour Life			J kg-cm ² [in-lb-sec ² x10 ⁻⁴]	Torsional Stiffness Nm/arc-min [in-lb/arc-min]
		T _r (1000 rpm) Nm [in-lb]	T _r (3000 rpm) Nm [in-lb]	T _r (5000 rpm) Nm [in-lb]		T _r (1000 rpm) Nm [in-lb]	T _r (3000 rpm) Nm [in-lb]	T _r (5000 rpm) Nm [in-lb]		
UT006-004	4:1	48 [426]	44 [387]	38 [340]	101 [891]	47 [417]	36 [322]	31 [276]	.20 [1.80]	2.62 [23.2]
UT006-005	5:1	47 [413]	43 [377]	40 [355]	98 [865]	46 [404]	38 [336]	33 [288]	.13 [1.16]	2.56 [22.7]
UT006-007	7:1	45 [394]	41 [362]	39 [345]	93 [825]	44 [385]	40 [354]	35 [307]	.11 [.96]	2.42 [21.5]
UT006-010	10:1	26 [232]	23 [200]	21 [186]	88 [781]	24 [215]	21 [185]	19 [173]	.10 [.85]	1.93 [17.1]
UT006-016	16:1	53 [467]	49 [435]	47 [419]	110 [975]	52 [456]	48 [426]	46 [410]	.16 [1.44]	2.67 [23.7]
UT006-020	20:1	53 [472]	50 [442]	48 [426]	111 [985]	52 [462]	49 [432]	47 [417]	.16 [1.44]	2.62 [23.2]
UT006-025	25:1	51 [456]	48 [428]	47 [413]	107 [948]	50 [446]	47 [418]	46 [404]	.16 [1.44]	2.58 [22.8]
UT006-028	28:1	54 [481]	51 [452]	49 [437]	113 [999]	53 [470]	50 [442]	48 [427]	.16 [1.44]	2.46 [21.8]
UT006-035	35:1	52 [463]	49 [437]	48 [423]	108 [960]	51 [453]	48 [427]	47 [414]	.10 [.85]	2.54 [22.5]
UT006-040	40:1	55 [489]	52 [462]	51 [447]	114 [1011]	54 [478]	51 [451]	49 [438]	.10 [.85]	2.67 [23.7]
UT006-050	50:1	53 [471]	50 [446]	49 [433]	110 [971]	52 [461]	49 [436]	48 [423]	.10 [.85]	2.62 [23.2]
UT006-070	70:1	50 [445]	48 [423]	46 [411]	103 [913]	49 [435]	47 [414]	45 [402]	.10 [.85]	2.46 [21.8]
UT006-100	100:1	35 [307]	30 [269]	29 [253]	96 [851]	32 [284]	28 [249]	26 [234]	.10 [.85]	2.03 [17.9]

All ratios are available to ship in 24 hours through the Gearhead Express Program.

¹ Ratios are exact, higher ratios are also available, consult factory.
 T_r = Rated output torque at rated speed for specific hours of life.

T_{peak} = Allowable momentary peak torque for emergency stop or heavy shock loading.
 J = Mass moment of inertia reflected to the input shaft (including pinion assembly).

UltraTRUE™ Size 75

Helical True Planetary™ Gearheads

Metric

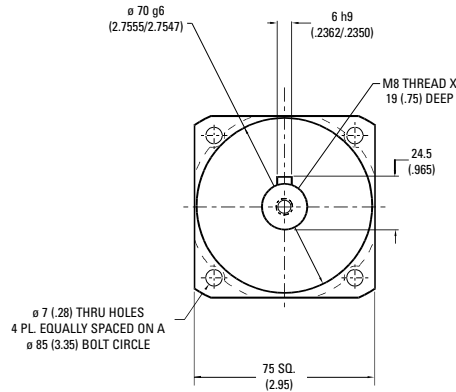
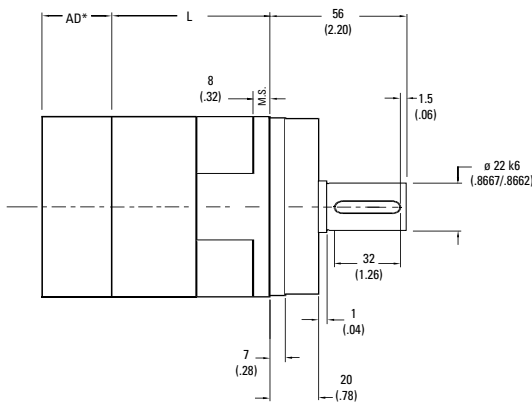

Ratio ¹	Dimension 'L' mm [in]	Backlash [arc-min]	Weight kg [lb]	Efficiency
4:1 to 10:1	60 [2.35]	4 max	2.5 [5.5]	95%
16:1 to 100:1	117 [4.60]	5 max	3.0 [6.6]	90%

All dimensions are: mm (inch)
 AD** = Adapter length
 Adapter length will vary depending on motor.
 M.S.= Mounting Surface
 Efficiency is calculated at 100% of the rated torque.

Performance Specifications

Part Number	Ratio ¹	10,000 Hour Life			T _{peak} Nm [in-lb]	20,000 Hour Life			J kg-cm ² [in-lb-sec ² x10 ⁻⁴]	Torsional Stiffness Nm/arc-min [in-lb/arc-min]
		T _r (1000 rpm) Nm [in-lb]	T _r (3000 rpm) Nm [in-lb]	T _r (5000 rpm) Nm [in-lb]		T _r (1000 rpm) Nm [in-lb]	T _r (3000 rpm) Nm [in-lb]	T _r (5000 rpm) Nm [in-lb]		
UT075-004	4:1	86 [762]	78 [689]	73 [649]	179 [1581]	84 [746]	74 [652]	63 [559]	,46 [4.1]	7,00 [61.9]
UT075-005	5:1	84 [740]	76 [672]	72 [636]	174 [1537]	82 [723]	74 [657]	66 [583]	,38 [3.4]	6,86 [60.7]
UT075-007	7:1	80 [706]	73 [646]	69 [615]	166 [1469]	78 [690]	71 [632]	68 [601]	,31 [2.8]	6,07 [53.7]
UT075-010	10:1	47 [418]	41 [360]	38 [335]	157 [1393]	44 [387]	38 [333]	35 [310]	,27 [2.4]	4,46 [39.5]
UT075-016	16:1	95 [838]	88 [780]	85 [749]	197 [1743]	93 [820]	86 [762]	83 [732]	,31 [2.8]	7,36 [65.1]
UT075-020	20:1	96 [849]	90 [792]	86 [762]	199 [1762]	94 [830]	88 [775]	84 [746]	,31 [2.8]	7,20 [63.7]
UT075-025	25:1	93 [820]	87 [767]	84 [740]	192 [1698]	91 [801]	85 [750]	82 [723]	,31 [2.8]	7,07 [62.6]
UT075-028	28:1	98 [864]	92 [811]	88 [782]	202 [1789]	96 [845]	90 [793]	86 [765]	,28 [2.5]	6,45 [57.1]
UT075-035	35:1	94 [834]	89 [784]	86 [758]	194 [1721]	92 [815]	87 [767]	84 [741]	,16 [1.4]	6,68 [59.1]
UT075-040	40:1	99 [880]	94 [829]	91 [802]	205 [1813]	97 [861]	92 [811]	89 [785]	,16 [1.4]	7,37 [65.2]
UT075-050	50:1	96 [849]	91 [801]	88 [777]	197 [1743]	94 [830]	89 [784]	86 [759]	,16 [1.4]	7,22 [63.9]
UT075-070	70:1	91 [802]	86 [760]	83 [738]	185 [1639]	89 [784]	84 [743]	82 [722]	,16 [1.4]	6,48 [57.3]
UT075-100	100:1	63 [554]	55 [486]	52 [456]	173 [1529]	58 [513]	51 [450]	48 [422]	,15 [1.3]	4,50 [39.8]

All ratios are available to ship in 24 hours through the Gearhead Express Program.

¹ Ratios are exact, higher ratios are also available, consult factory.
 T_r = Rated output torque at rated speed for specific hours of life.

T_{peak} = Allowable momentary peak torque for emergency stop or heavy shock loading.
 J = Mass moment of inertia reflected to the input shaft (including pinion assembly).

UltraTRUE™ Size 90

Helical True Planetary™ Gearheads

Metric

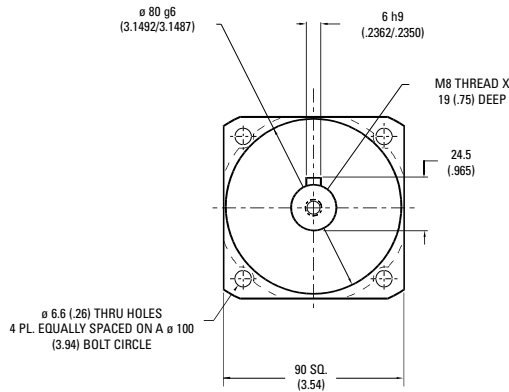
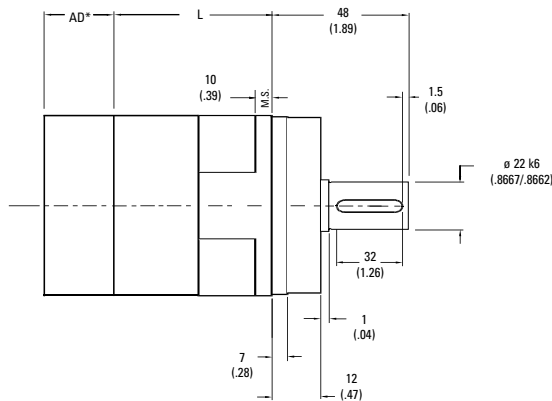

Ratio ¹	Dimension 'L' mm [in]	Backlash [arc-min]	Weight kg [lb]	Efficiency
4:1 to 10:1	68 [2.66]	4 max	2,5 [5.5]	95%
16:1 to 100:1	125 [4.91]	5 max	3,0 [6.6]	90%

All dimensions are: mm (inch)

AD** = Adapter length

Adapter length and width will vary depending on motor.

M.S.= Mounting Surface

Efficiency is calculated at 100% of the rated torque.

Performance Specifications

Part Number	Ratio ¹	10,000 Hour Life			T _{peak} Nm [in-lb]	20,000 Hour Life			J kg-cm ² [in-lb-sec ² ×10 ⁻⁴]	Torsional Stiffness Nm/arc-min [in-lb/arc-min]
		T _r (1000 rpm) Nm [in-lb]	T _r (3000 rpm) Nm [in-lb]	T _r (5000 rpm) Nm [in-lb]		T _r (1000 rpm) Nm [in-lb]	T _r (3000 rpm) Nm [in-lb]	T _r (5000 rpm) Nm [in-lb]		
UT090-004	4:1	86 [762]	78 [689]	73 [649]	179 [1581]	84 [746]	74 [652]	63 [559]	,46 [4.1]	7,00 [61.9]
UT090-005	5:1	84 [740]	76 [672]	72 [636]	174 [1537]	82 [723]	74 [657]	66 [583]	,38 [3.4]	6,86 [60.7]
UT090-007	7:1	80 [706]	73 [646]	69 [615]	166 [1469]	78 [690]	71 [632]	68 [601]	,31 [2.8]	6,07 [53.7]
UT090-010	10:1	47 [418]	41 [360]	38 [335]	157 [1393]	44 [387]	38 [333]	35 [310]	,27 [2.4]	4,46 [39.5]
UT090-016	16:1	95 [838]	88 [780]	85 [749]	197 [1743]	93 [820]	86 [762]	83 [732]	,31 [2.8]	7,36 [65.1]
UT090-020	20:1	96 [849]	90 [792]	86 [762]	199 [1762]	94 [830]	88 [775]	84 [746]	,31 [2.8]	7,20 [63.7]
UT090-025	25:1	93 [820]	87 [767]	84 [740]	192 [1698]	91 [801]	85 [750]	82 [723]	,31 [2.8]	7,07 [62.6]
UT090-028	28:1	98 [864]	92 [811]	88 [782]	202 [1789]	96 [845]	90 [793]	86 [765]	,28 [2.5]	6,45 [57.1]
UT090-035	35:1	94 [834]	89 [784]	86 [758]	194 [1721]	92 [815]	87 [767]	84 [741]	,16 [1.4]	6,68 [59.1]
UT090-040	40:1	99 [880]	94 [829]	91 [802]	205 [1813]	97 [861]	92 [811]	89 [785]	,16 [1.4]	7,37 [65.2]
UT090-050	50:1	96 [849]	91 [801]	88 [777]	197 [1743]	94 [830]	89 [784]	86 [759]	,16 [1.4]	7,22 [63.9]
UT090-070	70:1	91 [802]	86 [760]	83 [738]	185 [1639]	89 [784]	84 [743]	82 [722]	,16 [1.4]	6,48 [57.3]
UT090-100	100:1	63 [554]	55 [486]	52 [456]	173 [1529]	58 [513]	51 [450]	48 [422]	,15 [1.3]	4,50 [39.8]

¹ Ratios are exact, higher ratios are also available, consult factory.
T_r = Rated output torque at rated speed for specific hours of life.

T_{peak} = Allowable momentary peak torque for emergency stop or heavy shock loading.
J = Mass moment of inertia reflected to the input shaft (including pinion assembly).

UltraTRUE™ Size 10

Helical True Planetary™ Gearheads

Metric

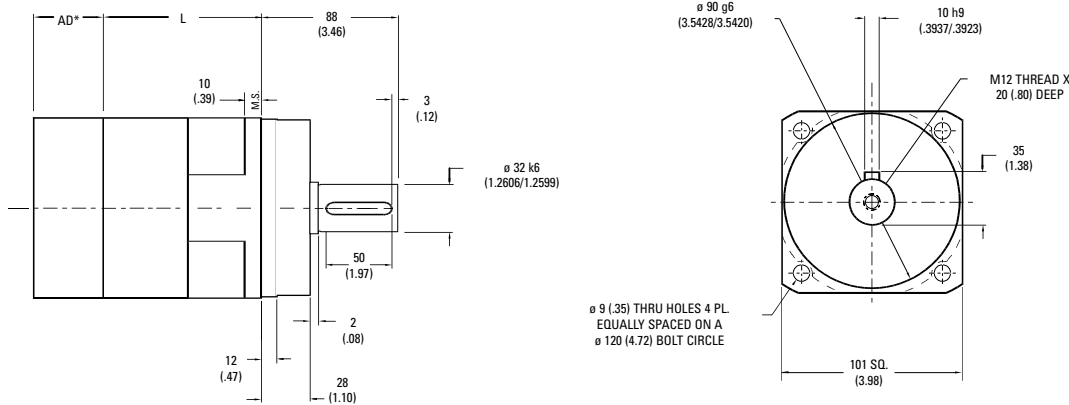

Ratio ¹	Dimension 'L' mm [in]	Backlash [arc-min]	Weight kg [lb]	Efficiency
4:1 to 10:1	78 [3.07]	4 max	6 [13]	95%
16:1 to 100:1	146 [5.75]	5 max	8 [18]	90%

All dimensions are: mm (inch)
 AD** = Adapter length
 Adapter length and width will vary depending on motor.
 M.S.= Mounting Surface
 Efficiency is calculated at 100% of the rated torque.

Performance Specifications

Part Number	Ratio ¹	10,000 Hour Life			T _{peak} Nm [in-lb]	20,000 Hour Life			J kg-cm ² [in-lb-sec ² ×10 ⁻⁴]	Torsional Stiffness Nm/arc-min [in-lb/arc-min]
		T _r (1000 rpm) Nm [in-lb]	T _r (3000 rpm) Nm [in-lb]	T _r (5000 rpm) Nm [in-lb]		T _r (1000 rpm) Nm [in-lb]	T _r (3000 rpm) Nm [in-lb]	T _r (5000 rpm) Nm [in-lb]		
UT010-004	4:1	252 [2229]	217 [1922]	186 [1649]	514 [4548]	245 [2171]	176 [1561]	151 [1340]	1,58 [14.0]	25,7 [227]
UT010-005	5:1	245 [2168]	220 [1950]	194 [1720]	501 [4434]	240 [2120]	184 [1628]	158 [1397]	1,36 [12.0]	22,8 [202]
UT010-007	7:1	234 [2074]	213 [1882]	201 [1780]	481 [4256]	229 [2028]	196 [1736]	168 [1489]	,97 [8.6]	21,1 [187]
UT010-010	10:1	138 [1220]	118 [1048]	110 [971]	457 [4044]	128 [1129]	110 [969]	102 [898]	,90 [8.0]	14,4 [128]
UT010-016	16:1	279 [2471]	258 [2284]	247 [2184]	575 [5085]	273 [2416]	252 [2233]	229 [2030]	1,10 [9.7]	27,3 [242]
UT010-020	20:1	283 [2505]	263 [2325]	252 [2229]	582 [5152]	277 [2450]	257 [2273]	245 [2171]	1,10 [9.7]	24,3 [215]
UT010-025	25:1	274 [2422]	255 [2256]	245 [2168]	562 [4974]	268 [2368]	249 [2206]	240 [2120]	1,10 [9.7]	24,3 [215]
UT010-028	28:1	289 [2554]	269 [2384]	259 [2293]	592 [5242]	282 [2498]	263 [2331]	253 [2242]	,94 [8.3]	21,1 [187]
UT010-035	35:1	279 [2468]	261 [2310]	252 [2227]	571 [5054]	273 [2413]	255 [2259]	246 [2177]	,79 [7.0]	20,9 [185]
UT010-040	40:1	294 [2604]	276 [2442]	266 [2357]	602 [5327]	288 [2546]	270 [2388]	260 [2305]	,79 [7.0]	27,4 [243]
UT010-050	50:1	284 [2514]	267 [2364]	258 [2286]	579 [5128]	278 [2458]	261 [2312]	253 [2235]	,78 [6.9]	24,1 [213]
UT010-070	70:1	269 [2380]	254 [2246]	246 [2177]	546 [4832]	263 [2327]	248 [2197]	241 [2129]	,78 [6.9]	21,1 [187]
UT010-100	100:1	184 [1626]	161 [1423]	151 [1335]	510 [4510]	170 [1504]	149 [1317]	140 [1235]	,78 [6.9]	17,2 [152]

All ratios are available to ship in 24 hours through the Gearhead Express Program.

¹ Ratios are exact, higher ratios are also available, consult factory.
 T_r = Rated output torque at rated speed for specific hours of life.

T_{peak} = Allowable momentary peak torque for emergency stop or heavy shock loading.
 J = Mass moment of inertia reflected to the input shaft (including pinion assembly).

UltraTRUE™ Size 115

Helical True Planetary™ Gearheads

Metric

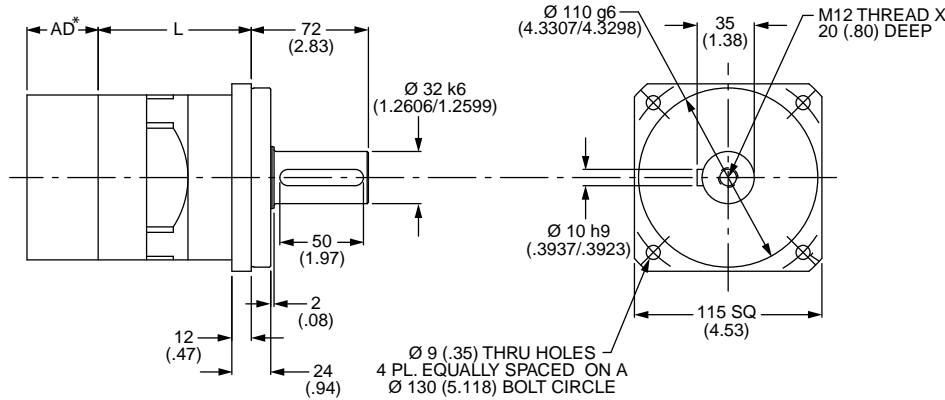

Ratio ¹	Dimension 'L' mm [in]	Backlash [arc-min]	Weight kg [lb]	Efficiency
4:1 to 10:1	94 [3.70]	4 max	6 [13]	95%
16:1 to 100:1	162 [6.38]	5 max	6 [18]	88%

All dimensions are: mm (inch)
 AD** = Adapter length
 Adapter length and width will vary depending on motor.
 M.S.= Mounting Surface
 Efficiency is calculated at 100% of the rated torque.

Performance Specifications

Part Number	Ratio ¹	10,000 Hour Life				T _{peak} Nm [in-lb]	20,000 Hour Life			J kg-cm ² [in-lb-sec ² x10 ⁻⁴]	Torsional Stiffness Nm/arc-min [in-lb/arc-min]
		T _r (1000 rpm) Nm [in-lb]	T _r (3000 rpm) Nm [in-lb]	T _r (5000 rpm) Nm [in-lb]	T _r (1000 rpm) Nm [in-lb]		T _r (3000 rpm) Nm [in-lb]	T _r (5000 rpm) Nm [in-lb]			
UT115-004	4:1	252 [2229]	217 [1922]	186 [1649]	514 [4548]	245 [2171]	176 [1561]	151 [1340]	1,58 [14.0]	25,7 [227]	
UT115-005	5:1	245 [2168]	220 [1950]	194 [1720]	501 [4434]	240 [2120]	184 [1628]	158 [1397]	1,36 [12.0]	22,8 [202]	
UT115-007	7:1	234 [2074]	213 [1882]	201 [1780]	481 [4256]	229 [2028]	196 [1736]	168 [1489]	,97 [8.6]	21,1 [187]	
UT115-010	10:1	138 [1220]	118 [1048]	110 [971]	457 [4044]	128 [1129]	110 [969]	102 [898]	,90 [8.0]	14,4 [128]	
UT115-016	16:1	279 [2471]	258 [2284]	247 [2184]	575 [5085]	273 [2416]	252 [2233]	229 [2030]	1,10 [9.7]	27,3 [242]	
UT115-020	20:1	283 [2505]	263 [2325]	252 [2229]	582 [5152]	277 [2450]	257 [2273]	245 [2171]	1,10 [9.7]	24,3 [215]	
UT115-025	25:1	274 [2422]	255 [2256]	245 [2168]	562 [4974]	268 [2368]	249 [2206]	240 [2120]	1,10 [9.7]	24,3 [215]	
UT115-028	28:1	289 [2554]	269 [2384]	259 [2293]	592 [5242]	282 [2498]	263 [2331]	253 [2242]	,94 [8.3]	21,1 [187]	
UT115-035	35:1	279 [2468]	261 [2310]	252 [2227]	571 [5054]	273 [2413]	255 [2259]	246 [2177]	,79 [7.0]	20,9 [185]	
UT115-040	40:1	294 [2604]	276 [2442]	266 [2357]	602 [5327]	288 [2546]	270 [2388]	260 [2305]	,79 [7.0]	27,4 [243]	
UT115-050	50:1	284 [2514]	267 [2364]	258 [2286]	579 [5128]	278 [2458]	261 [2312]	253 [2235]	,78 [6.9]	24,1 [213]	
UT115-070	70:1	269 [2380]	254 [2246]	246 [2177]	546 [4832]	263 [2327]	248 [2197]	241 [2129]	,78 [6.9]	21,1 [187]	
UT115-100	100:1	184 [1626]	161 [1423]	151 [1335]	510 [4510]	170 [1504]	149 [1317]	140 [1235]	,78 [6.9]	17,2 [152]	

¹ Ratios are exact, higher ratios are also available, consult factory.
 T_r = Rated output torque at rated speed for specific hours of life.

T_{peak} = Allowable momentary peak torque for emergency stop or heavy shock loading.
 J = Mass moment of inertia reflected to the input shaft (including pinion assembly).

UltraTRUE™ Size 14

Helical True Planetary™ Gearheads

Metric

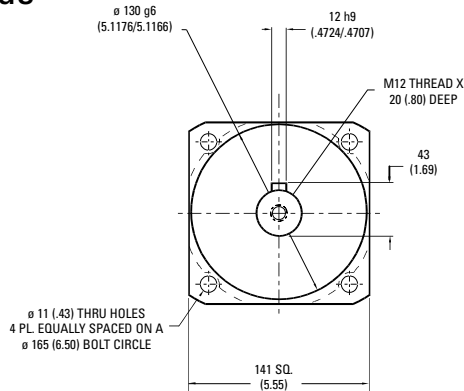
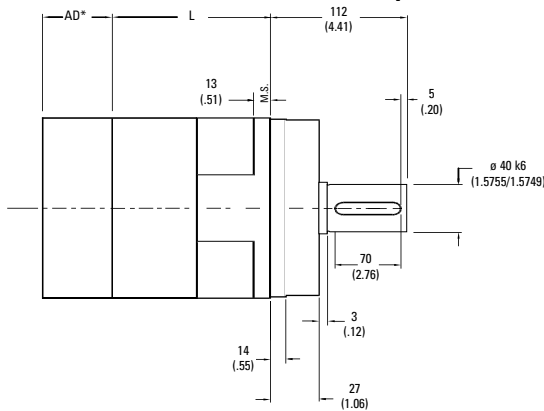

Ratio ¹	Dimension 'L' mm [in]	Backlash [arc-min]	Weight kg [lb]	Efficiency
4:1 to 10:1	110.5 [4.35]	4 max	14 [31]	95%
16:1 to 100:1	195 [7.69]	5 max	18 [40]	90%

All dimensions are: mm (inch)
 AD** = Adapter length
 Adapter length and width will vary depending on motor.
 M.S.= Mounting Surface
 Efficiency is calculated at 100% of the rated torque.

Performance Specifications

Part Number	Ratio ¹	10,000 Hour Life			T _{peak} Nm [in-lb]	20,000 Hour Life			J kg-cm ² [in-lb-sec ² x10 ⁻⁴]	Torsional Stiffness Nm/arc-min [in-lb/arc-min]
		T _r (1000 rpm) Nm [in-lb]	T _r (3000 rpm) Nm [in-lb]	T _r (5000 rpm) Nm [in-lb]		T _r (1000 rpm) Nm [in-lb]	T _r (3000 rpm) Nm [in-lb]	T _r (5000 rpm) Nm [in-lb]		
UT014-004	4:1	588 [5207]	521 [4613]	454 [4022]	1184 [10,479]	575 [5092]	430 [3808]	369 [3267]	6,51 [57.6]	55 [487]
UT014-005	5:1	572 [5066]	511 [4519]	474 [4191]	1156 [10,229]	560 [4954]	448 [3968]	385 [3404]	5,02 [44.4]	51 [452]
UT014-007	7:1	549 [4857]	494 [4375]	466 [4120]	1113 [9851]	537 [4749]	478 [4232]	410 [3631]	3,80 [33.6]	47 [420]
UT014-010	10:1	329 [2913]	282 [2492]	260 [2304]	1062 [9399]	305 [2696]	261 [2306]	241 [2132]	3,39 [30.0]	35 [311]
UT014-016	16:1	657 [5817]	604 [5346]	576 [5095]	1340 [11,860]	643 [5688]	591 [5227]	559 [4951]	4,21 [37.2]	58 [514]
UT014-020	20:1	667 [5902]	616 [5449]	588 [5207]	1360 [12,035]	652 [5772]	602 [5328]	575 [5092]	4,07 [36.0]	54 [479]
UT014-025	25:1	645 [5706]	598 [5288]	572 [5066]	1314 [11,625]	630 [5579]	584 [5171]	560 [4954]	4,07 [36.0]	54 [479]
UT014-028	28:1	681 [6026]	632 [5597]	607 [5369]	1387 [12,274]	666 [5892]	618 [5473]	593 [5250]	3,53 [31.2]	47 [417]
UT014-035	35:1	658 [5820]	613 [5424]	589 [5215]	1338 [11,837]	643 [5691]	599 [5304]	576 [5099]	2,99 [26.4]	44 [391]
UT014-040	40:1	695 [6150]	649 [5745]	625 [5530]	1412 [12,498]	680 [6014]	635 [5617]	611 [5408]	2,99 [26.4]	58 [512]
UT014-050	50:1	671 [5935]	628 [5560]	606 [5363]	1360 [12,034]	656 [5803]	614 [5437]	593 [5244]	2,85 [25.2]	54 [479]
UT014-070	70:1	635 [5623]	598 [5291]	578 [5118]	1283 [11,359]	621 [5499]	585 [5174]	565 [5004]	2,85 [25.2]	49 [435]
UT014-100	100:1	441 [3898]	385 [3407]	361 [3193]	1201 [10,627]	408 [3607]	356 [3153]	334 [2954]	2,85 [25.2]	35 [312]

All ratios are available to ship in 24 hours through the Gearhead Express Program.

¹ Ratios are exact, higher ratios are also available, consult factory.
 T_r = Rated output torque at rated speed for specific hours of life.

T_{peak} = Allowable momentary peak torque for emergency stop or heavy shock loading.
 J = Mass moment of inertia reflected to the input shaft (including pinion assembly).

UltraTRUE™ Size 18

Helical True Planetary™ Gearheads

Metric

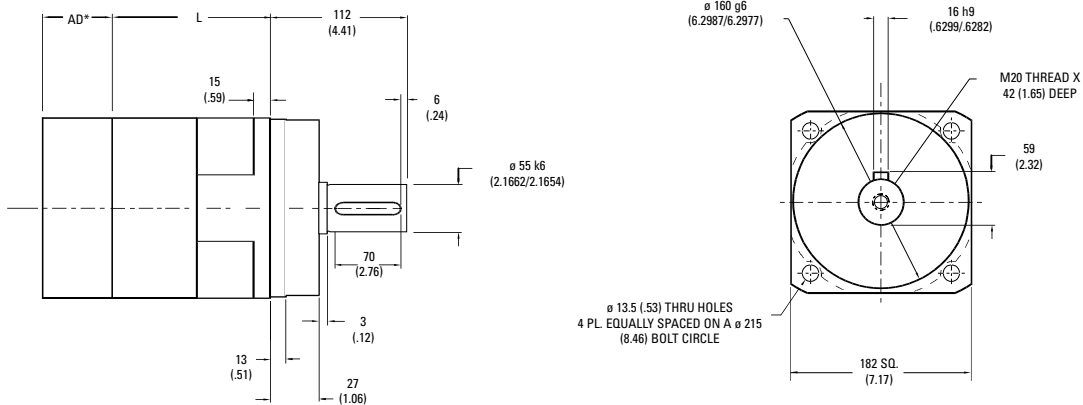

Ratio ¹	Dimension 'L' in [mm]	Backlash [arc-min]	Weight lb [kg]	Efficiency
4:1 to 10:1	136 [5.35]	4 max	40 [88]	95%
16:1 to 100:1	244 [9.59]	5 max	45 [99]	90%

All dimensions are: mm (inch)
 AD** = Adapter length
 Adapter length and width will vary depending on motor.
 M.S.= Mounting Surface
 Efficiency is calculated at 100% of the rated torque.

Performance Specifications

Part Number	Ratio ¹	10,000 Hour Life			T _{peak} Nm [in-lb]	20,000 Hour Life			J kg-cm ² [in-lb-sec ² ×10 ⁻⁴]	Torsional Stiffness Nm/arc-min [in-lb/arc-min]
		T _r (1000 rpm) Nm [in-lb]	T _r (3000 rpm) Nm [in-lb]	T _r (5000 rpm) Nm [in-lb]		T _r (1000 rpm) Nm [in-lb]	T _r (3000 rpm) Nm [in-lb]	T _r (5000 rpm) Nm [in-lb]		
UT018-004	4:1	1368 [12108]	1184 [10476]	1016 [8988]	2713 [24010]	1337 [11832]	962 [8509]	825 [7300]	25,9 [229]	153 [1358]
UT018-005	5:1	1333 [11800]	1179 [10430]	1058 [9366]	2654 [23492]	1304 [11539]	1002 [8868]	860 [7608]	20,0 [177]	150 [1330]
UT018-007	7:1	1281 [11338]	1144 [10128]	1073 [9494]	2565 [22699]	1253 [11087]	1069 [9458]	917 [8114]	14,6 [129]	134 [1185]
UT018-010	10:1	775 [6856]	660 [5841]	609 [5387]	2456 [21734]	717 [6344]	611 [5404]	563 [4984]	13,0 [115]	101 [893]
UT018-016	16:1	1541 [13641]	1408 [12457]	1336 [11827]	3111 [27532]	1507 [13339]	1376 [12181]	1250 [11065]	16,1 [142]	161 [1429]
UT018-020	20:1	1566 [13855]	1437 [12716]	1368 [12108]	3162 [27986]	1531 [13549]	1405 [12434]	1337 [11832]	15,6 [138]	156 [1382]
UT018-025	25:1	1515 [13407]	1396 [12359]	1333 [11800]	3060 [27078]	1481 [13110]	1366 [12085]	1304 [11539]	15,6 [138]	131 [1160]
UT018-028	28:1	1600 [14164]	1479 [13088]	1414 [12515]	3233 [28612]	1565 [13851]	1446 [12798]	1383 [12237]	13,5 [119]	138 [1225]
UT018-035	35:1	1547 [13691]	1435 [12701]	1376 [12174]	3122 [27633]	1513 [13388]	1403 [12420]	1345 [11904]	11,4 [101]	124 [1098]
UT018-040	40:1	1636 [14475]	1521 [13460]	1460 [12920]	3300 [29201]	1599 [14154]	1487 [13162]	1428 [12634]	11,4 [101]	161 [1429]
UT018-050	50:1	1579 [13978]	1474 [13042]	1418 [12547]	3181 [28153]	1544 [13668]	1441 [12754]	1386 [12269]	10,9 [96]	156 [1382]
UT018-070	70:1	1498 [13256]	1404 [12429]	1355 [11993]	3008 [26621]	1465 [12963]	1373 [12154]	1325 [11728]	10,9 [96]	138 [1225]
UT018-100	100:1	1042 [9218]	909 [8043]	851 [7528]	2819 [24949]	964 [8529]	841 [7442]	787 [6966]	10,9 [96]	103 [908]

¹ Ratios are exact, higher ratios are also available, consult factory.
 T_r = Rated output torque at rated speed for specific hours of life.

T_{peak} = Allowable momentary peak torque for emergency stop or heavy shock loading.
 J = Mass moment of inertia reflected to the input shaft (including pinion assembly).

UltraTRUE™ Size 22

Helical True Planetary™ Gearheads

Metric

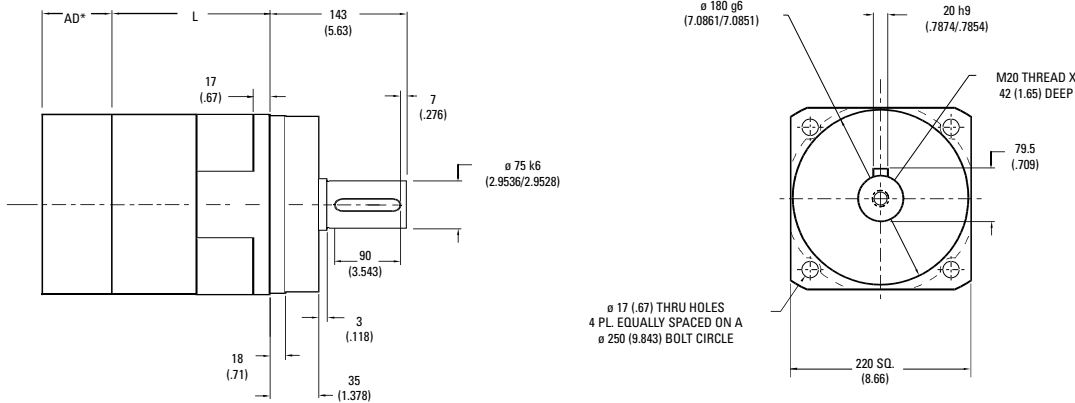

Ratio ¹	Dimension 'L' mm [in]	Backlash [arc-min]	Weight kg [lb]	Efficiency
4:1 to 10:1	131 [5.15]	4 max	74 [162]	93%
16:1 to 100:1	232 [9.13]	5 max	95 [209]	88%

All dimensions are: mm (inch)
 AD** = Adapter length
 Adapter length will vary depending on motor.
 M.S. = Mounting Surface
 Efficiency is calculated at 100% of the rated torque.

Performance Specifications

Part Number	Ratio ¹	10,000 Hour Life			T _{peak} Nm [in-lb]	20,000 Hour Life			J kg-cm ² [in-lb-sec ² x10 ⁻⁴]	Torsional Stiffness Nm/arc-min [in-lb/arc-min]
		T _r (1000 rpm) Nm [in-lb]	T _r (3000 rpm) Nm [in-lb]	T _r (5000 rpm) Nm [in-lb]		T _r (1000 rpm) Nm [in-lb]	T _r (3000 rpm) Nm [in-lb]	T _r (5000 rpm) Nm [in-lb]		
UT022-004	4:1	2256 [19694]	1786 [15806]	1532 [13560]	4644 [41096]	2017 [17850]	1451 [12838]	1245 [11014]	87,0 [7.70]	429 [3793]
UT022-005	5:1	2181 [19300]	1862 [16475]	1596 [14125]	4548 [40250]	2102 [18600]	1511 [13375]	1297 [11475]	73,4 [6.50]	414 [3661]
UT022-007	7:1	2090 [18496]	1857 [16432]	1703 [15073]	4370 [38671]	2042 [18075]	1613 [14271]	1383 [12243]	62,6 [5.55]	363 [3212]
UT022-010	10:1	1263 [11178]	1072 [9488]	987 [8737]	4301 [38060]	1167 [10325]	992 [8779]	914 [8085]	56,9 [5.04]	253 [2235]
UT022-016	16:1	2521 [20292]	2293 [20292]	2170 [19202]	5247 [46437]	2464 [21805]	2199 [19459]	1886 [16694]	87,3 [7.73]	436 [3858]
UT022-020	20:1	2561 [20732]	2343 [20732]	2224 [19683]	5323 [47107]	2504 [22164]	2291 [20273]	2017 [17850]	73,6 [6.52]	436 [3856]
UT022-025	25:1	2484 [20205]	2283 [20205]	2174 [19239]	5151 [45583]	2427 [21480]	2232 [19757]	2102 [18605]	73,1 [6.47]	418 [3699]
UT022-028	28:1	2620 [21365]	2414 [21365]	2302 [20375]	5427 [48027]	2560 [22660]	2361 [20892]	2231 [19476]	62,7 [5.55]	435 [3854]
UT022-035	35:1	2541 [20788]	2349 [20788]	2246 [19878]	5243 [46397]	2481 [21961]	2297 [20327]	2196 [19438]	62,5 [5.53]	418 [3698]
UT022-040	40:1	2680 [21998]	2486 [21998]	2381 [21069]	5524 [48888]	2619 [23182]	2431 [21510]	2328 [20602]	57,2 [5.06]	435 [3851]
UT022-050	50:1	2595 [21371]	2415 [21371]	2318 [20516]	5328 [47156]	2536 [22443]	2361 [20898]	2267 [20062]	57,1 [5.05]	418 [3696]
UT022-070	70:1	2461 [20373]	2302 [20373]	2217 [19623]	5025 [44470]	2405 [21288]	2251 [19922]	2168 [19189]	57,0 [5.04]	366 [3226]
UT022-100	100:1	1666 [13121]	1483 [13121]	1387 [12273]	4852 [42941]	1571 [13902]	1369 [12116]	1283 [11356]	56,9 [5.04]	253 [2238]

¹ Ratios are exact, higher ratios are also available, consult factory.
 T_r = Rated output torque at rated speed for specific hours of life.

T_{peak} = Allowable momentary peak torque for emergency stop or heavy shock loading.
 J = Mass moment of inertia reflected to the input shaft (including pinion assembly).

Radial and Axial Load Ratings

UT006

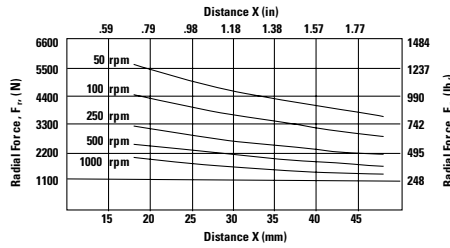
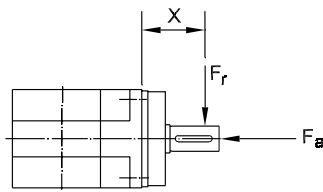

Speed rpm	Axial Load, F_a N [lb _f]
50	7198 [1618]
100	5710 [1284]
250	4208 [946]
500	3342 [751]
1000	2652 [596]

UT075

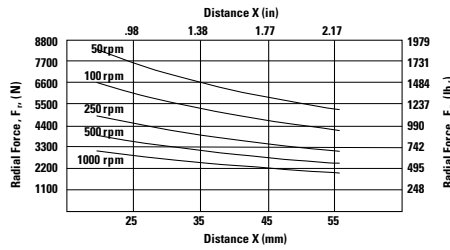
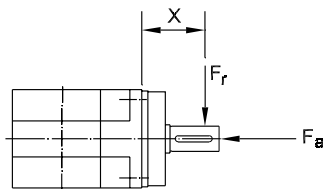

Speed rpm	Axial Load, F_a N [lb _f]
50	9903 [2227]
100	7863 [1768]
250	5793 [1303]
500	4599 [1034]
1000	3650 [821]

UT090

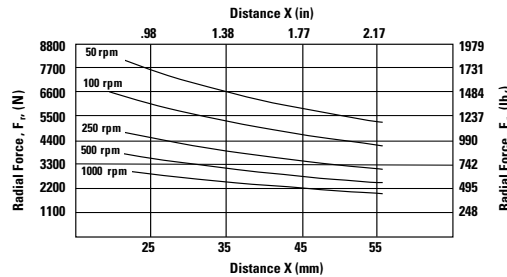
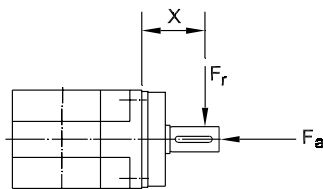

Speed rpm	Axial Load, F_a N [lb _f]
50	9903 [2227]
100	7863 [1768]
250	5793 [1303]
500	4599 [1034]
1000	3650 [821]

UT010

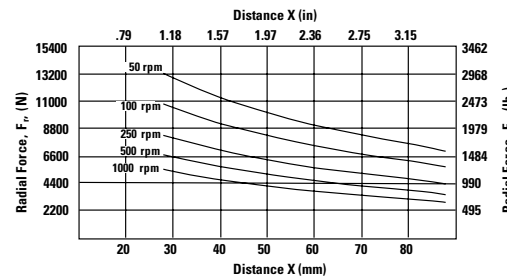
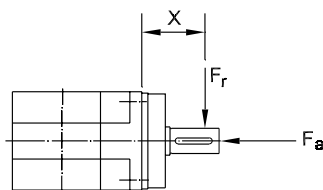

Speed rpm	Axial Load, F_a N [lb _f]
50	13,675 [3075]
100	11,107 [2497]
250	8435 [1897]
500	6855 [1542]
1000	5568 [1252]

These graphs display the allowable radial load at a given distance (X) from the mounting surface based on an L₁₀ life of 10,000 hours for the mean output speed n_{mout} , as described on page 10.

Radial and Axial Load Ratings

UT115

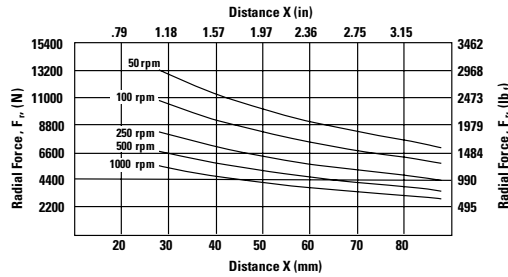
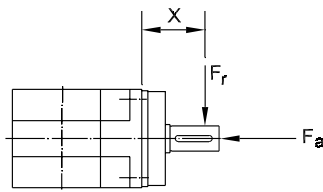

Speed rpm	Axial Load, F_a N [lb _f]
50	13,675 [3075]
100	11,107 [2497]
250	8435 [1897]
500	6855 [1542]
1000	5568 [1252]

UT014

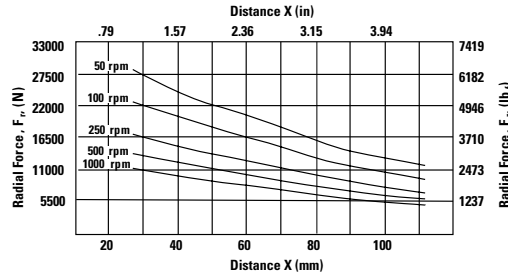
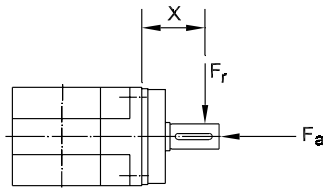

Speed rpm	Axial Load, F_a N [lb _f]
50	25,374 [5705]
100	20,609 [4633]
250	15,657 [3520]
500	12,716 [2859]
1000	10,329 [2322]

UT018

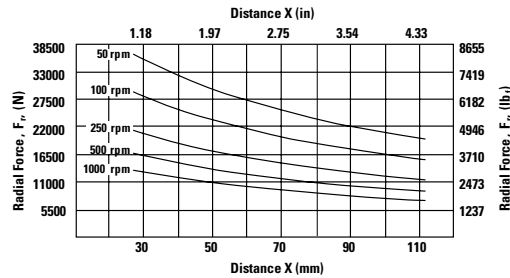
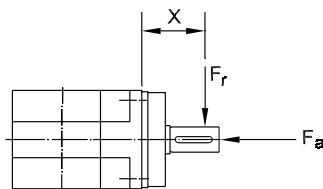

Speed rpm	Axial Load, F_a N [lb _f]
50	34,538 [7765]
100	27,414 [6163]
250	20,197 [4541]
500	16,034 [3605]
1000	12,726 [2861]

UT022

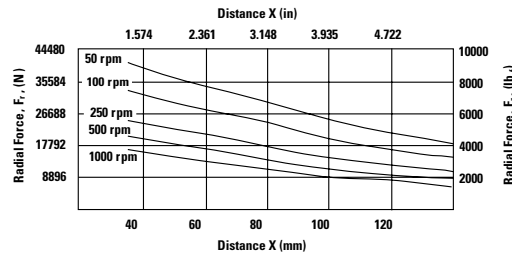
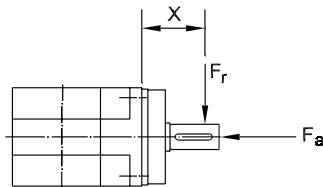

Speed rpm	Axial Load, F_a N [lb _f]
50	32,351 [3655]
100	26,277 [2969]
250	19,962 [2256]
500	16,214 [1832]

These graphs display the allowable radial load at a given distance (X) from the mounting surface based on an L_{10} life of 10,000 hours for the mean output speed n_{mout} , as described on page 10.



UltraTRUE 90™

Helical Right Angle Gearheads

Ready for Immediate Delivery	
Precision	4 arc-minutes
Frame Sizes	60mm, 75mm, 90mm, 100mm, 115mm, 142mm and 180mm
Torque Capacity	up to 3111 Nm
Ratio Availability	1:1 thru 50:1
Radial load capacity	up to 37910 N
Mounting System	RediMount™

- ① **Tapered roller bearings**
provide high axial and radial load carrying capacity
- ② **Helical crowned**
HRC 55-60 steel gears
provide higher torque capacity and smoother operation
- ③ **PowerTRUE™ gear technology**
provides high torque capacity in a compact package
- ④ **RediMount™ system**
provides error-free motor installation

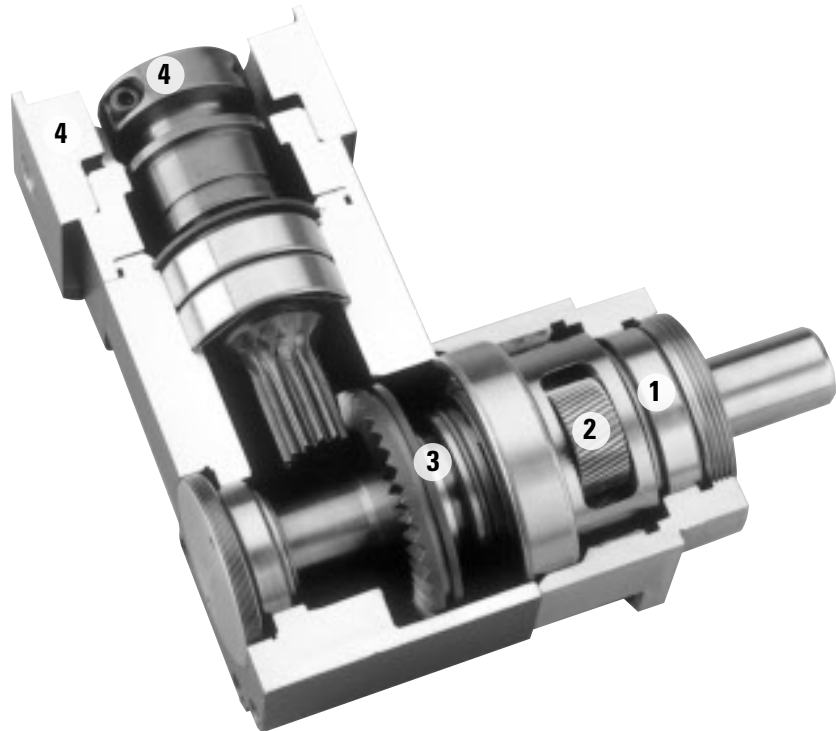

UltraTRUE 90™ Size 60

Helical Right Angle Gearheads

Metric

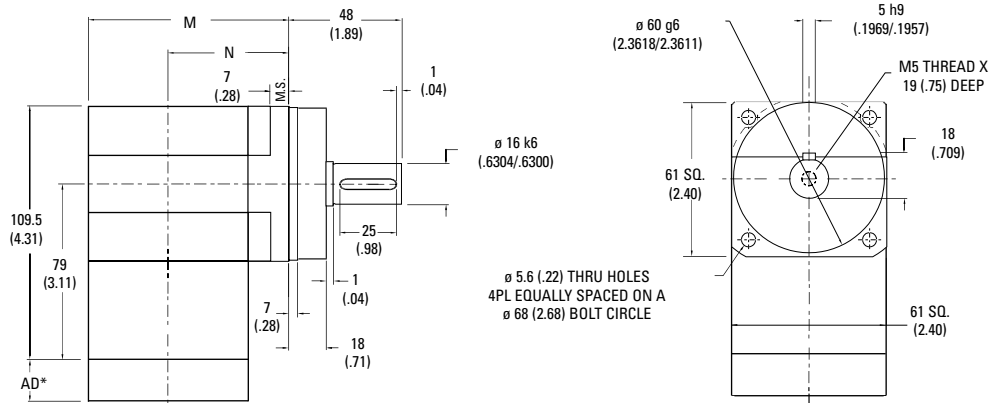

Ratio ¹	Dimension 'M' mm [in]	Dimension 'N' mm [in]	Backlash [arc-min]	Weight kg [lb]	Efficiency
1:1 to 5:1	86 [3.38]	55 [2.18]	4 max	2,5 [5.5]	98%
8:1 to 50:1	95 [3.75]	65 [2.55]	5 max	3 [6.6]	93%

All dimensions are: mm (inch)
 AD** = Adapter length
 Adapter length will vary depending on motor.
 M.S. = Mounting Surface
 Efficiency is calculated at 100% of the rated torque.

Performance Specifications

Part Number	Ratio ¹	10,000 Hour Life			T _{peak} Nm [in-lb]	20,000 Hour Life			J kg-cm ² [in-lb-sec ² x10 ⁻⁴]	Torsional Stiffness Nm/arc-min [in-lb/arc-min]
		T _r (1000 rpm) Nm [in-lb]	T _r (3000 rpm) Nm [in-lb]	T _r (5000 rpm) Nm [in-lb]		T _r (1000 rpm) Nm [in-lb]	T _r (3000 rpm) Nm [in-lb]	T _r (5000 rpm) Nm [in-lb]		
UTR006-001	1:1	9 [77]	8 [70]	7 [64]	28 [247]	8 [71]	7 [65]	7 [59]	,97 [8.4]	2,1 [19]
UTR006-002	2:1	19 [170]	17 [155]	16 [140]	52 [456]	18 [157]	16 [143]	15 [129]	,50 [4.3]	3,2 [29]
UTR006-003	3:1	12 [108]	11 [99]	10 [89]	39 [342]	11 [100]	10 [91]	9 [82]	,43 [3.7]	3,6 [32]
UTR006-004	4:1	9 [80]	8 [73]	7 [66]	34 [301]	8 [73]	8 [67]	7 [61]	,40 [3.4]	3,8 [34]
UTR006-005	5:1	7 [65]	7 [60]	6 [54]	26 [228]	7 [60]	6 [55]	6 [50]	,39 [3.4]	3,9 [35]
UTR006-008	8:1	51 [447]	47 [413]	45 [394]	106 [938]	49 [438]	45 [397]	38 [340]	,50 [4.4]	2,1 [18]
UTR006-010	10:1	49 [433]	45 [401]	43 [384]	102 [906]	48 [423]	44 [392]	40 [355]	,49 [4.4]	1,8 [16]
UTR006-012	12:1	49 [432]	45 [394]	40 [356]	109 [961]	45 [399]	41 [364]	37 [329]	,39 [3.5]	2,0 [18]
UTR006-014	14:1	46 [411]	43 [383]	42 [368]	97 [860]	45 [402]	42 [374]	41 [360]	,49 [4.4]	2,4 [22]
UTR006-015	15:1	50 [443]	47 [413]	45 [397]	105 [927]	49 [433]	46 [404]	44 [388]	,39 [3.4]	2,4 [21]
UTR006-016	16:1	36 [318]	33 [290]	30 [262]	110 [975]	33 [294]	30 [268]	27 [242]	,39 [3.5]	2,4 [22]
UTR006-020	20:1	45 [398]	41 [363]	37 [328]	106 [939]	41 [367]	38 [335]	34 [303]	,39 [3.5]	2,4 [21]
UTR006-025	25:1	37 [326]	34 [298]	30 [269]	107 [948]	34 [301]	31 [275]	28 [249]	,38 [3.4]	2,3 [21]
UTR006-028	28:1	48 [427]	45 [401]	44 [388]	100 [887]	47 [417]	44 [392]	43 [379]	,39 [3.5]	2,2 [20]
UTR006-030	30:1	30 [266]	26 [232]	25 [217]	93 [822]	28 [246]	24 [215]	23 [201]	,42 [3.7]	2,3 [20]
UTR006-035	35:1	49 [432]	46 [407]	43 [377]	101 [894]	48 [422]	44 [385]	39 [348]	,38 [3.4]	2,3 [20]
UTR006-040	40:1	31 [275]	27 [240]	25 [225]	94 [830]	29 [255]	25 [223]	24 [208]	,39 [3.5]	2,4 [22]
UTR006-050	50:1	32 [283]	28 [247]	26 [232]	94 [836]	30 [262]	26 [229]	24 [215]	,38 [3.4]	2,4 [21]

¹ Ratios are exact, higher ratios are also available, consult factory.
 T_r = Rated output torque at rated speed for specific hours of life.

T_{peak} = Allowable momentary peak torque for emergency stop or heavy shock loading.
 J = Mass moment of inertia reflected to the input shaft (including pinion assembly).

UltraTRUE 90™ Size 75

Helical Right Angle Gearheads

Metric

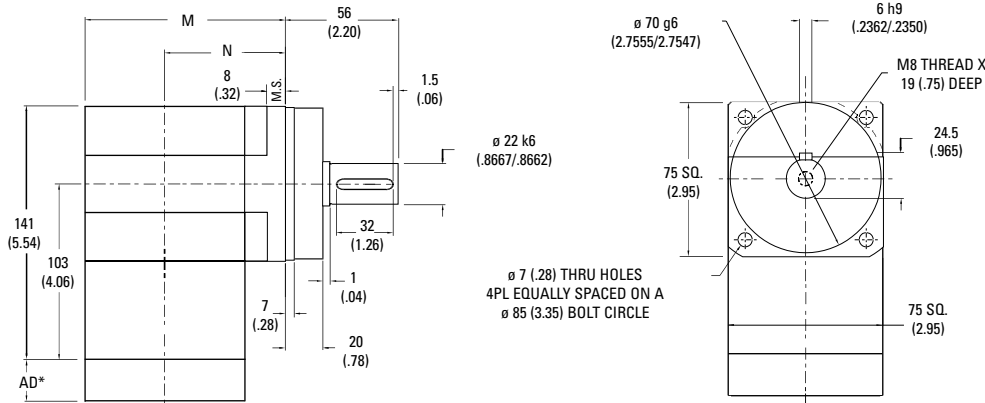

Ratio ¹	Dimension 'M' mm [in]	Dimension 'N' mm [in]	Backlash [arc-min]	Weight kg [lb]	Efficiency
1:1 to 5:1	89 [3.51]	52 [2.04]	4 max	4.8 [10]	98%
8:1 to 50:1	114.5 [4.51]	77 [3.04]	5 max	5.3 [11.1]	93%

All dimensions are: mm (inch)
 AD** = Adapter length
 Adapter length will vary depending on motor.
 M.S.= Mounting Surface
 Efficiency is calculated at 100% of the rated torque.

Performance Specifications

Part Number	Ratio ¹	10,000 Hour Life			T _{peak} Nm [in-lb]	20,000 Hour Life			J kg-cm ² [in-lb-sec ² x10 ⁻⁴]	Torsional Stiffness Nm/arc-min [in-lb/arc-min]
		T _r (1000 rpm) Nm [in-lb]	T _r (3000 rpm) Nm [in-lb]	T _r (5000 rpm) Nm [in-lb]		T _r (1000 rpm) Nm [in-lb]	T _r (3000 rpm) Nm [in-lb]	T _r (5000 rpm) Nm [in-lb]		
UTR075-001	1:1	25 [220]	23 [200]	20 [181]	71 [625]	23 [203]	21 [185]	19 [167]	3,7 [33]	5,1 [46]
UTR075-002	2:1	56 [498]	51 [455]	46 [411]	159 [1410]	52 [460]	47 [420]	43 [380]	1,9 [17]	7,7 [69]
UTR075-003	3:1	37 [329]	34 [300]	31 [271]	129 [1146]	34 [304]	31 [277]	28 [250]	1,6 [15]	8,8 [78]
UTR075-004	4:1	28 [252]	26 [230]	23 [208]	99 [880]	26 [232]	24 [212]	22 [192]	1,5 [13]	9,2 [81]
UTR075-005	5:1	21 [185]	19 [169]	17 [153]	83 [735]	19 [171]	18 [156]	16 [141]	1,5 [13]	9,4 [83]
UTR075-008	8:1	91 [802]	83 [737]	79 [702]	189 [1671]	89 [785]	81 [720]	78 [686]	1,9 [17]	4,7 [41]
UTR075-010	10:1	88 [777]	81 [716]	77 [684]	183 [1617]	86 [759]	79 [700]	76 [669]	1,9 [17]	4,1 [36]
UTR075-012	12:1	93 [824]	86 [762]	82 [730]	194 [1715]	91 [805]	84 [746]	81 [714]	1,5 [14]	4,6 [41]
UTR075-014	14:1	83 [738]	77 [685]	74 [657]	174 [1536]	82 [722]	76 [670]	73 [643]	1,9 [17]	6,6 [58]
UTR075-015	15:1	90 [796]	84 [740]	80 [710]	187 [1656]	88 [779]	82 [723]	78 [694]	1,5 [13]	6,7 [59]
UTR075-016	16:1	95 [838]	88 [780]	85 [749]	197 [1743]	93 [820]	86 [762]	83 [732]	1,5 [14]	6,7 [59]
UTR075-020	20:1	91 [810]	85 [756]	82 [727]	190 [1681]	89 [792]	83 [739]	80 [711]	1,5 [14]	6,5 [58]
UTR075-025	25:1	93 [820]	87 [767]	84 [740]	192 [1698]	91 [801]	85 [750]	80 [705]	1,5 [13]	6,4 [57]
UTR075-028	28:1	87 [768]	81 [720]	79 [695]	179 [1589]	85 [751]	80 [704]	77 [679]	1,5 [14]	5,9 [52]
UTR075-030	30:1	54 [480]	47 [418]	44 [391]	166 [1473]	50 [444]	44 [387]	41 [361]	1,6 [15]	6,3 [56]
UTR075-035	35:1	88 [776]	83 [730]	80 [706]	181 [1603]	86 [759]	81 [714]	78 [690]	1,5 [13]	6,3 [56]
UTR075-040	40:1	56 [497]	49 [433]	46 [406]	168 [1489]	52 [460]	45 [401]	42 [375]	1,5 [14]	6,7 [59]
UTR075-050	50:1	58 [510]	50 [446]	47 [418]	170 [1500]	53 [472]	47 [413]	44 [387]	1,5 [13]	6,6 [58]

¹ Ratios are exact, higher ratios are also available, consult factory.
 T_r = Rated output torque at rated speed for specific hours of life.

T_{peak} = Allowable momentary peak torque for emergency stop or heavy shock loading.
 J = Mass moment of inertia reflected to the input shaft (including pinion assembly).

UltraTRUE 90™ Size 90

Helical Right Angle Gearheads

Metric

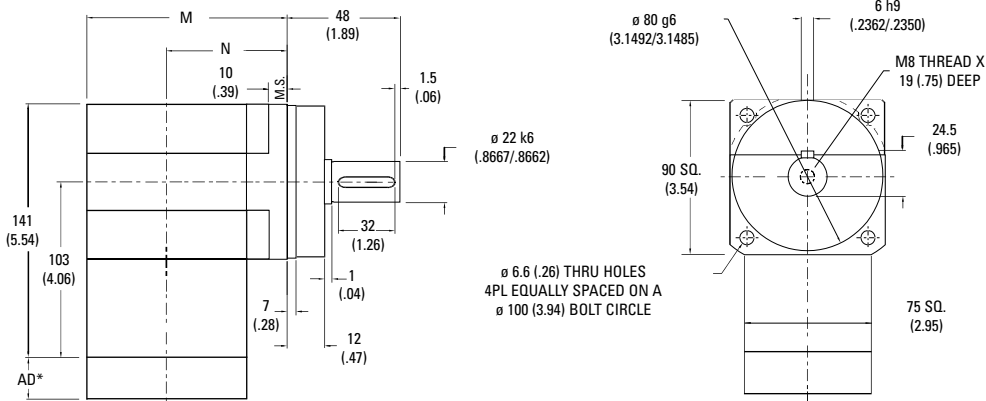

Ratio ¹	Dimension 'M' mm [in]	Dimension 'N' mm [in]	Backlash [arc-min]	Weight kg [lb]	Efficiency
1:1 to 5:1	97 [3.82]	60 [2.35]	4 max	4.8 [10]	98%
8:1 to 50:1	122.5 [4.82]	85 [3.35]	5 max	5.3 [11.1]	93%

All dimensions are: mm (inch)
 AD** = Adapter length
 Adapter length will vary depending on motor.
 M.S.= Mounting Surface
 Efficiency is calculated at 100% of the rated torque.

Performance Specifications

Part Number	Ratio ¹	10,000 Hour Life			T _{peak} Nm [in-lb]	20,000 Hour Life			J kg-cm ² [in-lb-sec ² ×10 ⁻⁴]	Torsional Stiffness Nm/arc-min [in-lb/arc-min]
		T _r (1000 rpm) Nm [in-lb]	T _r (3000 rpm) Nm [in-lb]	T _r (5000 rpm) Nm [in-lb]		T _r (1000 rpm) Nm [in-lb]	T _r (3000 rpm) Nm [in-lb]	T _r (5000 rpm) Nm [in-lb]		
UTR090-001	1:1	25 [220]	23 [200]	20 [181]	71 [625]	23 [203]	21 [185]	19 [167]	3,7 [33]	5,1 [46]
UTR090-002	2:1	56 [498]	51 [455]	46 [411]	159 [1410]	52 [460]	47 [420]	43 [380]	1,9 [17]	7,7 [69]
UTR090-003	3:1	37 [329]	34 [300]	31 [271]	129 [1146]	34 [304]	31 [277]	28 [250]	1,6 [15]	8,8 [78]
UTR090-004	4:1	28 [252]	26 [230]	23 [208]	99 [880]	26 [232]	24 [212]	22 [192]	1,5 [13]	9,2 [81]
UTR090-005	5:1	21 [185]	19 [169]	17 [153]	83 [735]	19 [171]	18 [156]	16 [141]	1,5 [13]	9,4 [83]
UTR090-008	8:1	91 [802]	83 [737]	79 [702]	189 [1671]	89 [785]	81 [720]	78 [686]	1,9 [17]	4,7 [41]
UTR090-010	10:1	88 [777]	81 [716]	77 [684]	183 [1617]	86 [759]	79 [700]	76 [669]	1,9 [17]	4,1 [36]
UTR090-012	12:1	93 [824]	86 [762]	82 [730]	194 [1715]	91 [805]	84 [746]	81 [714]	1,5 [14]	4,6 [41]
UTR090-014	14:1	83 [738]	77 [685]	74 [657]	174 [1536]	82 [722]	76 [670]	73 [643]	1,9 [17]	6,6 [58]
UTR090-015	15:1	90 [796]	84 [740]	80 [710]	187 [1656]	88 [779]	82 [723]	78 [694]	1,5 [13]	6,7 [59]
UTR090-016	16:1	95 [838]	88 [780]	85 [749]	197 [1743]	93 [820]	86 [762]	83 [732]	1,5 [14]	6,7 [59]
UTR090-020	20:1	91 [810]	85 [756]	82 [727]	190 [1681]	89 [792]	83 [739]	80 [711]	1,5 [14]	6,5 [58]
UTR090-025	25:1	93 [820]	87 [767]	84 [740]	192 [1698]	91 [801]	85 [750]	80 [705]	1,5 [13]	6,4 [57]
UTR090-028	28:1	87 [768]	81 [720]	79 [695]	179 [1589]	85 [751]	80 [704]	77 [679]	1,5 [14]	5,9 [52]
UTR090-030	30:1	54 [480]	47 [418]	44 [391]	166 [1473]	50 [444]	44 [387]	41 [361]	1,6 [15]	6,3 [56]
UTR090-035	35:1	88 [776]	83 [730]	80 [706]	181 [1603]	86 [759]	81 [714]	78 [690]	1,5 [13]	6,3 [56]
UTR090-040	40:1	56 [497]	49 [433]	46 [406]	168 [1489]	52 [460]	45 [401]	42 [375]	1,5 [14]	6,7 [59]
UTR090-050	50:1	58 [510]	50 [446]	47 [418]	170 [1500]	53 [472]	47 [413]	44 [387]	1,5 [13]	6,6 [58]

¹ Ratios are exact, higher ratios are also available, consult factory.
 T_r = Rated output torque at rated speed for specific hours of life.

T_{peak} = Allowable momentary peak torque for emergency stop or heavy shock loading.
 J = Mass moment of inertia reflected to the input shaft (including pinion assembly).

UltraTRUE 90™ Size 10

Helical Right Angle Gearheads

Metric

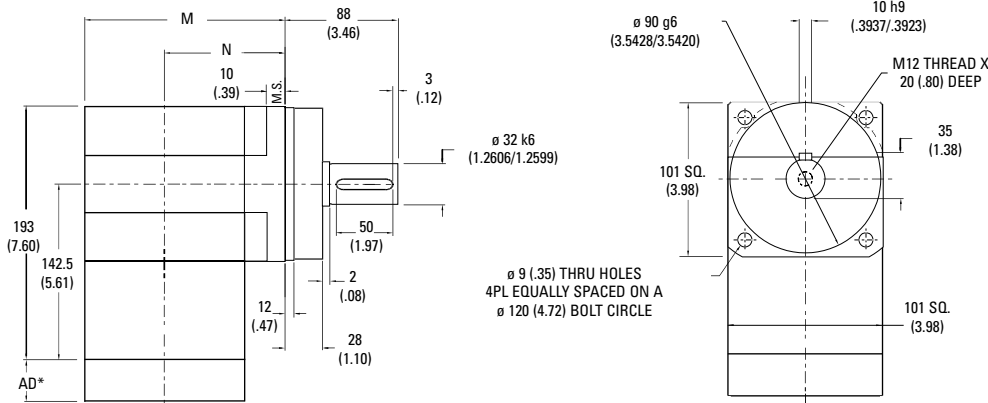

Ratio ¹	Dimension 'M' mm [in]	Dimension 'N' mm [in]	Backlash [arc-min]	Weight kg [lb]	Efficiency
1:1 to 5:1	121 [4.75]	70 [2.76]	4 max	11 [24]	98%
8:1 to 50:1	149 [5.88]	99 [3.89]	5 max	12 [26.2]	93%

All dimensions are: mm (inch)
 AD** = Adapter length
 Adapter length will vary depending on motor.
 M.S. = Mounting Surface
 Efficiency is calculated at 100% of the rated torque.

Performance Specifications

Part Number	Ratio ¹	10,000 Hour Life			T _{peak} Nm [in-lb]	20,000 Hour Life			J kg-cm ² [in-lb-sec ² x10 ⁻⁴]	Torsional Stiffness Nm/arc-min [in-lb/arc-min]
		T _r (1000 rpm) Nm [in-lb]	T _r (3000 rpm) Nm [in-lb]	T _r (5000 rpm) Nm [in-lb]		T _r (1000 rpm) Nm [in-lb]	T _r (3000 rpm) Nm [in-lb]	T _r (5000 rpm) Nm [in-lb]		
UTR010-001	1:1	73 [648]	67 [591]	60 [535]	232 [2052]	68 [598]	62 [546]	56 [494]	6,3 [56]	9,2 [81]
UTR010-002	2:1	131 [1157]	119 [1056]	108 [955]	323 [2856]	121 [1068]	110 [975]	100 [882]	3,2 [29]	15,0 [133]
UTR010-003	3:1	101 [898]	93 [820]	84 [741]	292 [2582]	94 [830]	86 [757]	77 [684]	2,8 [25]	17,1 [151]
UTR010-004	4:1	68 [598]	62 [546]	56 [494]	227 [2006]	62 [552]	57 [504]	51 [456]	2,6 [23]	17,9 [159]
UTR010-005	5:1	51 [449]	46 [409]	42 [370]	187 [1653]	47 [414]	43 [378]	39 [342]	2,5 [23]	18,3 [162]
UTR010-008	8:1	266 [2358]	243 [2147]	229 [2031]	547 [4844]	260 [2305]	217 [1923]	186 [1650]	3,3 [29]	16,6 [147]
UTR010-010	10:1	258 [2286]	236 [2092]	225 [1989]	531 [4701]	253 [2235]	226 [2005]	194 [1720]	3,3 [29]	13,1 [116]
UTR010-012	12:1	274 [2426]	252 [2229]	240 [2125]	564 [4992]	270 [2389]	245 [2171]	210 [1863]	2,6 [23]	18,8 [167]
UTR010-014	14:1	246 [2178]	227 [2007]	217 [1917]	506 [4481]	241 [2129]	222 [1963]	207 [1834]	3,3 [29]	23,1 [204]
UTR010-015	15:1	265 [2349]	245 [2168]	234 [2072]	546 [4832]	259 [2297]	240 [2120]	219 [1943]	2,5 [23]	24,3 [215]
UTR010-016	16:1	270 [2393]	247 [2184]	223 [1975]	575 [5085]	250 [2210]	228 [2016]	206 [1823]	2,6 [23]	24,8 [220]
UTR010-020	20:1	270 [2391]	251 [2219]	240 [2127]	555 [4916]	264 [2338]	245 [2170]	235 [2080]	2,6 [23]	22,1 [196]
UTR010-025	25:1	253 [2243]	231 [2047]	209 [1851]	562 [4974]	234 [2072]	214 [1890]	193 [1709]	2,5 [23]	22,1 [196]
UTR010-028	28:1	256 [2270]	239 [2119]	230 [2038]	526 [4659]	251 [2220]	234 [2072]	225 [1993]	2,6 [23]	19,2 [170]
UTR010-030	30:1	159 [1405]	138 [1220]	129 [1139]	488 [4317]	147 [1300]	128 [1129]	119 [1054]	2,8 [25]	19,1 [169]
UTR010-035	35:1	260 [2298]	243 [2152]	234 [2074]	532 [4707]	254 [2248]	238 [2104]	229 [2028]	2,5 [23]	19,0 [168]
UTR010-040	40:1	164 [1456]	143 [1267]	134 [1184]	494 [4372]	152 [1347]	132 [1173]	124 [1096]	2,6 [23]	24,9 [221]
UTR010-050	50:1	169 [1496]	147 [1304]	138 [1220]	498 [4410]	156 [1384]	136 [1207]	128 [1129]	2,5 [23]	21,9 [194]

¹ Ratios are exact, higher ratios are also available, consult factory.
 T_r = Rated output torque at rated speed for specific hours of life.

T_{peak} = Allowable momentary peak torque for emergency stop or heavy shock loading.
 J = Mass moment of inertia reflected to the input shaft (including pinion assembly).

UltraTRUE 90™ Size 115

Helical Right Angle Gearheads

Metric

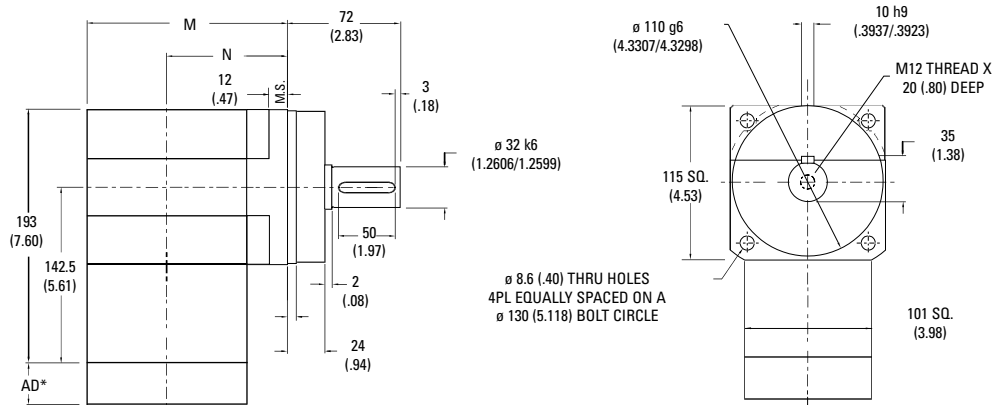

Ratio ¹	Dimension 'M' mm [in.]	Dimension 'N' mm [in.]	Backlash [arc-min]	Weight kg [lb]	Efficiency
1:1 to 5:1	136,7 [5.38]	86 [3.39]	4 max	11 [24]	98%
8:1 to 50:1	165 [6.51]	114,8 [4.52]	5 max	12 [26.2]	93%

All dimensions are: mm (inch)
 AD** = Adapter length
 Adapter length will vary depending on motor.
 M.S. = Mounting Surface
 Efficiency is calculated at 100% of the rated torque.

Performance Specifications

Part Number	Ratio ¹	10,000 Hour Life			T _{peak} Nm [in-lb]	20,000 Hour Life			J kg-cm ² [in-lb-sec ² x10 ⁻⁴]	Torsional Stiffness Nm/arc-min [in-lb/arc-min]
		T _r (1000 rpm) Nm [in-lb]	T _r (3000 rpm) Nm [in-lb]	T _r (5000 rpm) Nm [in-lb]		T _r (1000 rpm) Nm [in-lb]	T _r (3000 rpm) Nm [in-lb]	T _r (5000 rpm) Nm [in-lb]		
UTR115-001	1:1	73 [648]	67 [591]	60 [535]	232 [2052]	68 [598]	62 [546]	56 [494]	6,3 [56]	9,2 [81]
UTR115-002	2:1	131 [1157]	119 [1056]	108 [955]	323 [2856]	121 [1068]	110 [975]	100 [882]	3,2 [29]	15,0 [133]
UTR115-003	3:1	101 [898]	93 [820]	84 [741]	292 [2582]	94 [830]	86 [757]	77 [684]	2,8 [25]	17,1 [151]
UTR115-004	4:1	68 [598]	62 [546]	56 [494]	227 [2006]	62 [552]	57 [504]	51 [456]	2,6 [23]	17,9 [159]
UTR115-005	5:1	51 [449]	46 [409]	42 [370]	187 [1653]	47 [414]	43 [378]	39 [342]	2,5 [23]	18,3 [162]
UTR115-008	8:1	266 [2358]	243 [2147]	229 [2031]	547 [4844]	260 [2305]	217 [1923]	186 [1650]	3,3 [29]	16,6 [147]
UTR115-010	10:1	258 [2286]	236 [2092]	225 [1989]	531 [4701]	253 [2235]	226 [2005]	194 [1720]	3,3 [29]	13,1 [116]
UTR115-012	12:1	274 [2426]	252 [2229]	240 [2125]	564 [4992]	270 [2389]	245 [2171]	210 [1863]	2,6 [23]	18,8 [167]
UTR115-014	14:1	246 [2178]	227 [2007]	217 [1917]	506 [4481]	241 [2129]	222 [1963]	207 [1834]	3,3 [29]	23,1 [204]
UTR115-015	15:1	265 [2349]	245 [2168]	234 [2072]	546 [4832]	259 [2297]	240 [2120]	219 [1943]	2,5 [23]	24,3 [215]
UTR115-016	16:1	270 [2393]	247 [2184]	223 [1975]	575 [5085]	250 [2210]	228 [2016]	206 [1823]	2,6 [23]	24,8 [220]
UTR115-020	20:1	270 [2391]	251 [2219]	240 [2127]	555 [4916]	264 [2338]	245 [2170]	235 [2080]	2,6 [23]	22,1 [196]
UTR115-025	25:1	253 [2243]	231 [2047]	209 [1851]	562 [4974]	234 [2072]	214 [1890]	193 [1709]	2,5 [23]	22,1 [196]
UTR115-028	28:1	256 [2270]	239 [2119]	230 [2038]	526 [4659]	251 [2220]	234 [2072]	225 [1993]	2,6 [23]	19,2 [170]
UTR115-030	30:1	159 [1405]	138 [1220]	129 [1139]	488 [4317]	147 [1300]	128 [1129]	119 [1054]	2,8 [25]	19,1 [169]
UTR115-035	35:1	260 [2298]	243 [2152]	234 [2074]	532 [4707]	254 [2248]	238 [2104]	229 [2028]	2,5 [23]	19,0 [168]
UTR115-040	40:1	164 [1456]	143 [1267]	134 [1184]	494 [4372]	152 [1347]	132 [1173]	124 [1096]	2,6 [23]	24,9 [221]
UTR115-050	50:1	169 [1496]	147 [1304]	138 [1220]	498 [4410]	156 [1384]	136 [1207]	128 [1129]	2,5 [23]	21,9 [194]

¹ Ratios are exact, higher ratios are also available, consult factory.
 T_r = Rated output torque at rated speed for specific hours of life.

T_{peak} = Allowable momentary peak torque for emergency stop or heavy shock loading.
 J = Mass moment of inertia reflected to the input shaft (including pinion assembly).

UltraTRUE 90™ Size 14

Helical Right Angle Gearheads

Metric

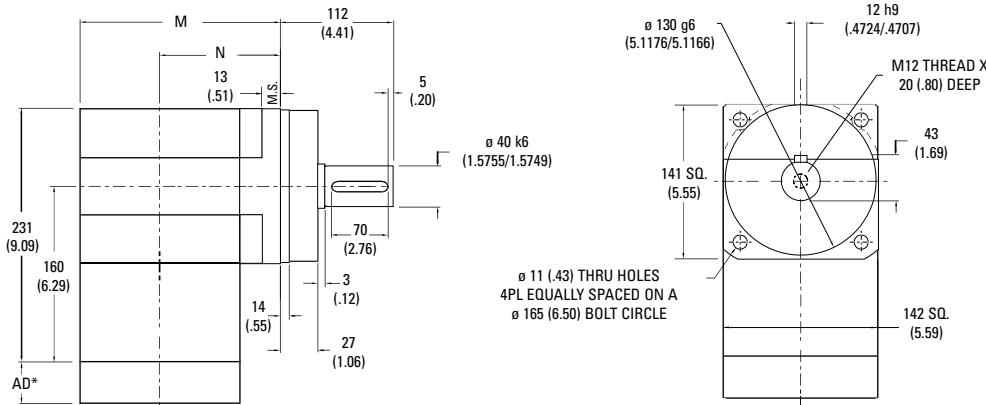

Ratio ¹	Dimension 'M' mm [in]	Dimension 'N' mm [in]	Backlash [arc-min]	Weight kg [lb]	Efficiency
1:1 to 5:1P	166 [6.54]	95 [3.74]	4 max	24 [53]	98%
8:1 to 50:1	222 [8.74]	151 [5.95]	5 max	29 [64]	93%

All dimensions are: mm (inch)
 AD** = Adapter length
 Adapter length will vary depending on motor.
 M.S. = Mounting Surface
 Efficiency is calculated at 100% of the rated torque.

Performance Specifications

Part Number	Ratio ¹	10,000 Hour Life			T _{peak} Nm [in-lb]	20,000 Hour Life			J kg-cm ² [in-lb-sec ² x10 ⁻⁴]	Torsional Stiffness Nm/arc-min [in-lb/arc-min]
		T _r (1000 rpm) Nm [in-lb]	T _r (3000 rpm) Nm [in-lb]	T _r (5000 rpm) Nm [in-lb]		T _r (1000 rpm) Nm [in-lb]	T _r (3000 rpm) Nm [in-lb]	T _r (5000 rpm) Nm [in-lb]		
UTR014-001	1:1	158 [1396]	144 [1274]	130 [1152]	380 [3363]	146 [1289]	133 [1177]	120 [1064]	32 [279]	28,4 [252]
UTR014-002	2:1	327 [2893]	298 [2640]	270 [2387]	708 [6270]	302 [2671]	275 [2438]	249 [2204]	16 [143]	46,6 [413]
UTR014-003	3:1	220 [1944]	201 [1774]	181 [1604]	545 [4822]	203 [1796]	185 [1639]	167 [1481]	14 [123]	52,9 [468]
UTR014-004	4:1	158 [1396]	144 [1274]	130 [1152]	471 [4172]	146 [1289]	133 [1177]	120 [1064]	13 [114]	55,5 [491]
UTR014-005	5:1	118 [1047]	108 [956]	98 [864]	396 [3506]	109 [967]	100 [883]	90 [798]	13 [112]	56,8 [503]
UTR014-008	8:1	625 [5531]	565 [5000]	533 [4719]	1269 [11,233]	611 [5408]	530 [4688]	454 [4022]	16 [146]	36,7 [325]
UTR014-010	10:1	606 [5364]	551 [4876]	522 [4617]	1233 [10,911]	593 [5245]	539 [4768]	474 [4192]	16 [145]	31,9 [282]
UTR014-012	12:1	644 [5702]	588 [5207]	559 [4944]	1313 [11,616]	630 [5576]	575 [5092]	513 [4542]	13 [116]	22,1 [195]
UTR014-014	14:1	578 [5118]	530 [4690]	504 [4461]	1179 [10,430]	565 [5005]	518 [4586]	493 [4363]	16 [145]	51,6 [457]
UTR014-015	15:1	624 [5522]	572 [5067]	545 [4824]	1272 [11,253]	610 [5399]	560 [4955]	533 [4717]	12 [113]	51,7 [457]
UTR014-016	16:1	631 [5587]	576 [5099]	521 [4610]	1340 [11,860]	583 [5160]	532 [4708]	481 [4257]	13 [115]	52,8 [467]
UTR014-020	20:1	636 [5627]	587 [5194]	561 [4963]	1296 [11,471]	622 [5503]	574 [5079]	548 [4854]	13 [115]	49,2 [435]
UTR014-025	25:1	592 [5240]	540 [4782]	488 [4324]	1314 [11,625]	547 [4839]	499 [4415]	451 [3992]	12 [113]	49,2 [435]
UTR014-028	28:1	605 [5350]	561 [4969]	539 [4767]	1231 [10,896]	591 [5232]	549 [4859]	527 [4661]	13 [115]	42,8 [379]
UTR014-030	30:1	380 [3363]	329 [2914]	307 [2715]	1143 [10,111]	352 [3112]	305 [2696]	284 [2512]	14 [124]	44,7 [396]
UTR014-035	35:1	612 [5420]	571 [5052]	549 [4857]	1246 [11,024]	599 [5300]	558 [4941]	537 [4750]	12 [113]	40,2 [356]
UTR014-040	40:1	394 [3486]	342 [3028]	319 [2826]	1159 [10,257]	364 [3226]	317 [2802]	295 [2615]	13 [115]	52,6 [466]
UTR014-050	50:1	405 [3584]	352 [3118]	329 [2914]	1171 [10,360]	375 [3316]	326 [2886]	305 [2696]	12 [112]	49,2 [435]

¹ Ratios are exact, higher ratios are also available, consult factory.
 T_r = Rated output torque at rated speed for specific hours of life.

T_{peak} = Allowable momentary peak torque for emergency stop or heavy shock loading.
 J = Mass moment of inertia reflected to the input shaft (including pinion assembly).

UltraTRUE 90™ Size 18

Helical Right Angle Gearheads

Metric

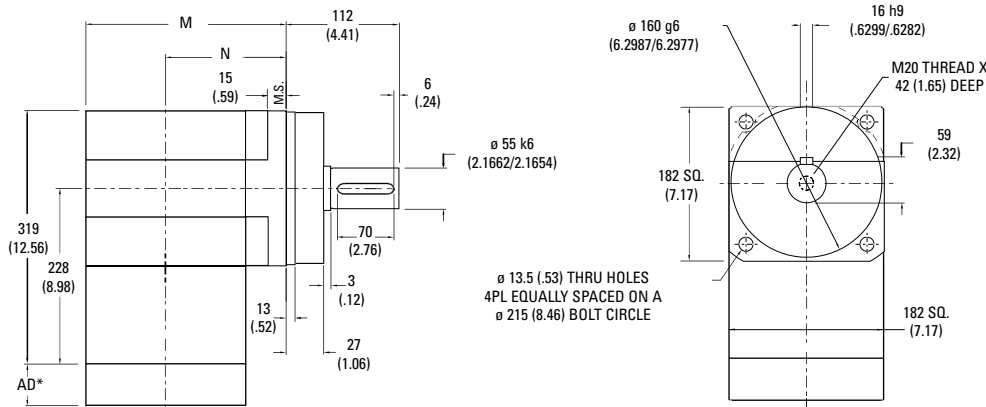

Ratio ¹	Dimension 'M' mm [in]	Dimension 'N' mm [in]	Backlash [arc-min]	Weight kg [lb]	Efficiency
1:1 to 5:1	219 [8.64]	128 [5.05]	4 max	43 [96]	98%
8:1 to 50:1	273 [10.76]	182 [7.18]	5 max	48 [106]	93%

All dimensions are: mm (inch)
 AD** = Adapter length
 Adapter length will vary depending on motor.
 M.S.= Mounting Surface
 Efficiency is calculated at 100% of the rated torque.

Performance Specifications

Part Number	Ratio ¹	10,000 Hour Life			T _{peak} Nm [in-lb]	20,000 Hour Life			J kg-cm ² [in-lb-sec ² x10 ⁻⁴]	Torsional Stiffness Nm/arc-min [in-lb/arc-min]
		T _r (1000 rpm) Nm [in-lb]	T _r (3000 rpm) Nm [in-lb]	T _r (5000 rpm) Nm [in-lb]		T _r (1000 rpm) Nm [in-lb]	T _r (3000 rpm) Nm [in-lb]	T _r (5000 rpm) Nm [in-lb]		
UTR018-001	1:1	248 [2195]	226 [2003]	205 [1811]	819 [7246]	229 [2027]	209 [1850]	189 [1672]	111 [985]	50 [440]
UTR018-002	2:1	654 [5786]	597 [5280]	539 [4774]	1911 [16914]	604 [5343]	551 [4876]	498 [4408]	57 [505]	82 [722]
UTR018-003	3:1	507 [4489]	463 [4096]	419 [3704]	1674 [14817]	468 [4145]	427 [3783]	386 [3420]	49 [434]	93 [820]
UTR018-004	4:1	361 [3192]	329 [2913]	298 [2633]	1190 [10536]	333 [2947]	304 [2690]	275 [2432]	46 [403]	97 [860]
UTR018-005	5:1	254 [2245]	231 [2048]	209 [1852]	837 [7410]	234 [2073]	214 [1892]	193 [1710]	45 [396]	99 [880]
UTR018-008	8:1	1460 [12920]	1309 [11589]	1230 [10888]	2929 [25920]	1428 [12634]	1184 [10476]	1016 [8988]	45 [401]	113 [998]
UTR018-010	10:1	1418 [12547]	1279 [11322]	1206 [10673]	2851 [25228]	1386 [12269]	1234 [10918]	1058 [9366]	45 [398]	92 [812]
UTR018-012	12:1	1509 [13352]	1368 [12108]	1294 [11448]	3040 [26900]	1475 [13057]	1337 [11832]	1147 [10150]	36 [317]	63 [560]
UTR018-014	14:1	1355 [11993]	1234 [10917]	1169 [10344]	2733 [24185]	1325 [11728]	1206 [10675]	1129 [9989]	45 [398]	111 [986]
UTR018-015	15:1	1463 [12944]	1333 [11800]	1265 [11192]	2950 [26109]	1430 [12657]	1304 [11539]	1195 [10578]	35 [310]	144 [1272]
UTR018-016	16:1	1443 [12769]	1317 [11652]	1191 [10536]	3111 [27532]	1332 [11791]	1216 [10760]	1099 [9729]	36 [316]	147 [1299]
UTR018-020	20:1	1493 [13209]	1370 [12121]	1304 [11541]	3014 [26674]	1460 [12917]	1339 [11853]	1275 [11285]	36 [316]	142 [1257]
UTR018-025	25:1	1268 [11226]	1158 [10245]	1047 [9263]	3060 [27078]	1171 [10366]	1069 [9460]	967 [8554]	35 [309]	119 [1055]
UTR018-028	28:1	1421 [12576]	1313 [11620]	1255 [11110]	2870 [25400]	1390 [12298]	1284 [11362]	1228 [10864]	36 [316]	126 [1113]
UTR018-030	30:1	897 [7935]	775 [6856]	721 [6377]	2665 [23583]	830 [7342]	717 [6344]	667 [5900]	38 [339]	113 [997]
UTR018-035	35:1	1441 [12750]	1337 [11828]	1281 [11338]	2908 [25736]	1409 [12468]	1307 [11567]	1253 [11087]	35 [309]	113 [998]
UTR018-040	40:1	930 [8231]	806 [7131]	751 [6645]	2708 [23967]	861 [7616]	746 [6599]	695 [6149]	36 [314]	147 [1299]
UTR018-050	50:1	956 [8465]	830 [7348]	775 [6856]	2739 [24239]	885 [7832]	768 [6799]	717 [6344]	35 [308]	142 [1257]

¹ Ratios are exact, higher ratios are also available, consult factory.
 T_r = Rated output torque at rated speed for specific hours of life.

T_{peak} = Allowable momentary peak torque for emergency stop or heavy shock loading.
 J = Mass moment of inertia reflected to the input shaft (including pinion assembly).

Radial and Axial Load Ratings

Ratios 1:1 thru 5:1 only

UTR006

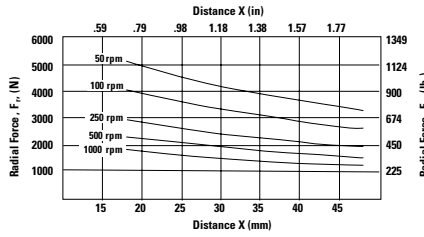
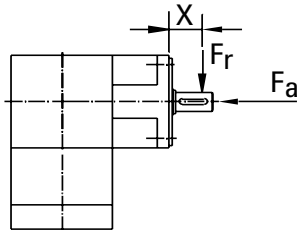

Speed rpm	Axial Load, F_a N [lb _f]
50	6543 [1471]
100	5191 [1167]
250	3825 [860]
500	3038 [683]
1000	2411 [542]

UTR075 and UTR090

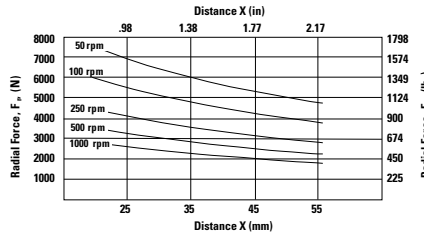
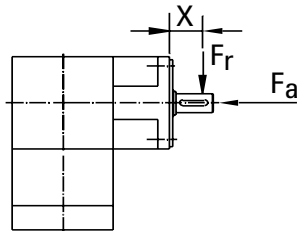

Speed rpm	Axial Load, F_a N [lb _f]
50	9003 [2024]
100	7148 [1607]
250	5266 [1184]
500	4181 [940]
1000	3318 [746]

UTR010 and UTR115

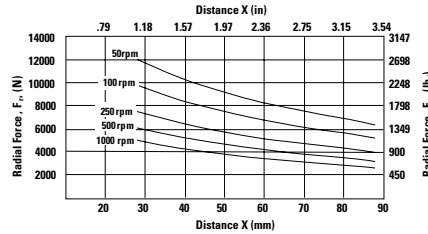
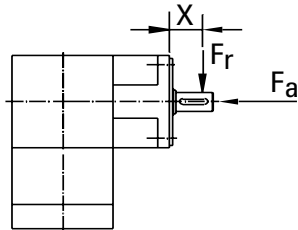

Speed rpm	Axial Load, F_a N [lb _f]
50	12,432 [2795]
100	10,097 [2270]
250	7668 [1724]
500	6232 [1401]
1000	5062 [1138]

UTR014

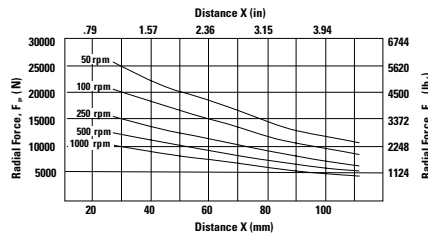
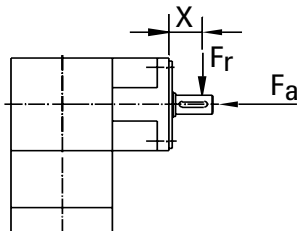

Speed rpm	Axial Load, F_a N [lb _f]
50	23,067 [5186]
100	18,735 [4212]
250	14,234 [3200]
500	11,560 [2599]
1000	9390 [2111]

UTR018

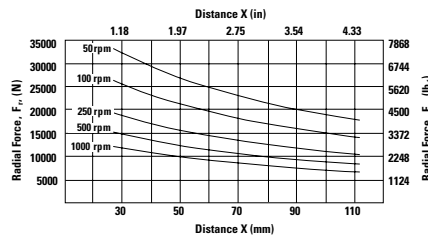
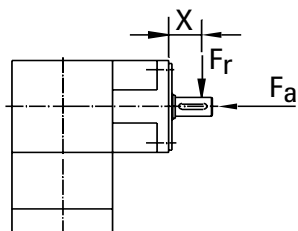

Speed rpm	Axial Load, F_a N [lb _f]
50	31,398 [7059]
100	24,922 [5603]
250	18,361 [4128]
500	14,576 [3277]
1000	11,569 [2601]

These graphs display the allowable radial load at a given distance (X) from the mounting surface based on an L₁₀ life of 10,000 hours for the mean output speed n_{mout} , as described on page 10.

Radial and Axial Load Ratings

Ratios 8:1 thru 50:1 only
UTR006

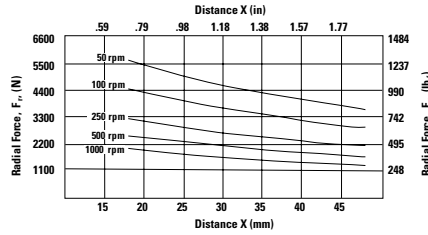
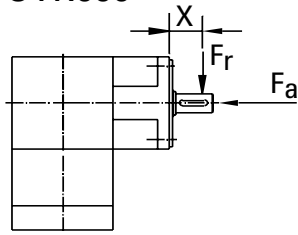

Speed rpm	Axial Load, F_a N [lb.]
50	7198 [1618]
100	5710 [1284]
250	4208 [946]
500	3342 [751]
1000	2652 [596]

UTR075 and UTR090

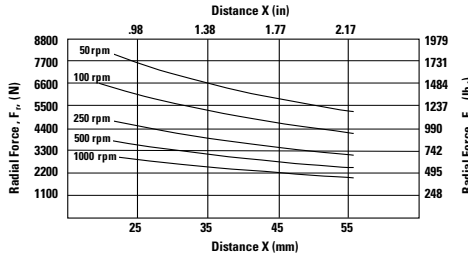
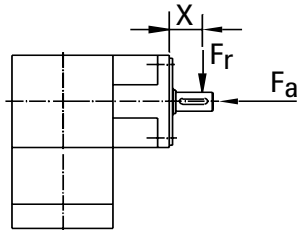

Speed rpm	Axial Load, F_a N [lb.]
50	9903 [2227]
100	7863 [1768]
250	5793 [1303]
500	4599 [1034]
1000	3650 [821]

UTR010 and UTR115

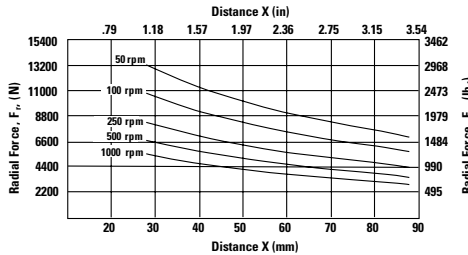
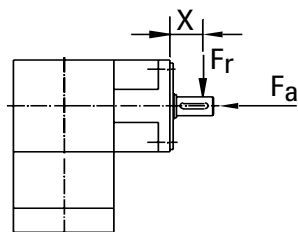

Speed rpm	Axial Load, F_a N [lb.]
50	13,675 [3075]
100	11,107 [2497]
250	8435 [1897]
500	6855 [1542]
1000	5568 [1252]

UTR014

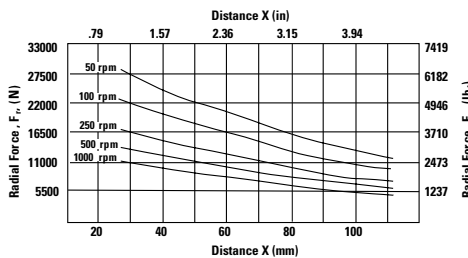
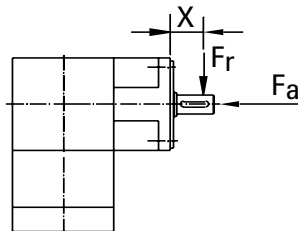

Speed rpm	Axial Load, F_a N [lb.]
50	25,374 [5705]
100	20,609 [4633]
250	15,657 [3520]
500	12,716 [2859]
1000	10,329 [2322]

UTR018

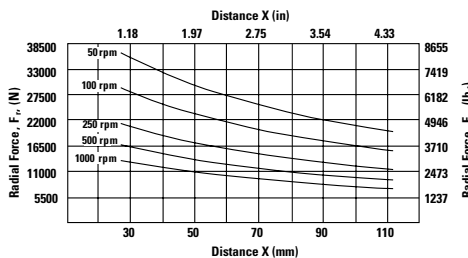
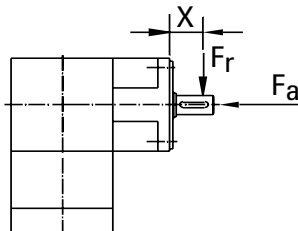

Speed rpm	Axial Load, F_a N [lb.]
50	34,538 [7765]
100	27,414 [6163]
250	20,197 [4541]
500	16,034 [3605]
1000	12,726 [2861]

These graphs display the allowable radial load at a given distance (X) from the mounting surface based on an L_{10} life of 10,000 hours for the mean output speed n_{mout} , as described on page 10.

EverTRUE™ Continuous Duty True Planetary™ Gearheads

Ready for Immediate Delivery	
Precision	4 arc-minutes
Frame Sizes	100mm, 140mm and 180mm
Torque Capacity	up to 1017 Nm
Ratio Availability	4:1 thru 100:1
Radial load capacity	up to 44600 N
Mounting System	RediMount™

- ① **Single piece output shaft with**
straddle mount bearing for
increased stiffness
- ② **High capacity tapered roller bearings**
- ③ **Double full complement needle**
bearings for continuous operation
- ④ **Gears lubricated with**
continuous duty grease
- ⑤ **True Planetary Gearing**
optimized for continuous duty
- ⑥ **Single piece output**
housing with integral internal gear
- ⑦ **Angular contact bearing**
- ⑧ **Input bearing with thermal**
compensation feature
- ⑨ **RediMount™ system**
provides error-free installation

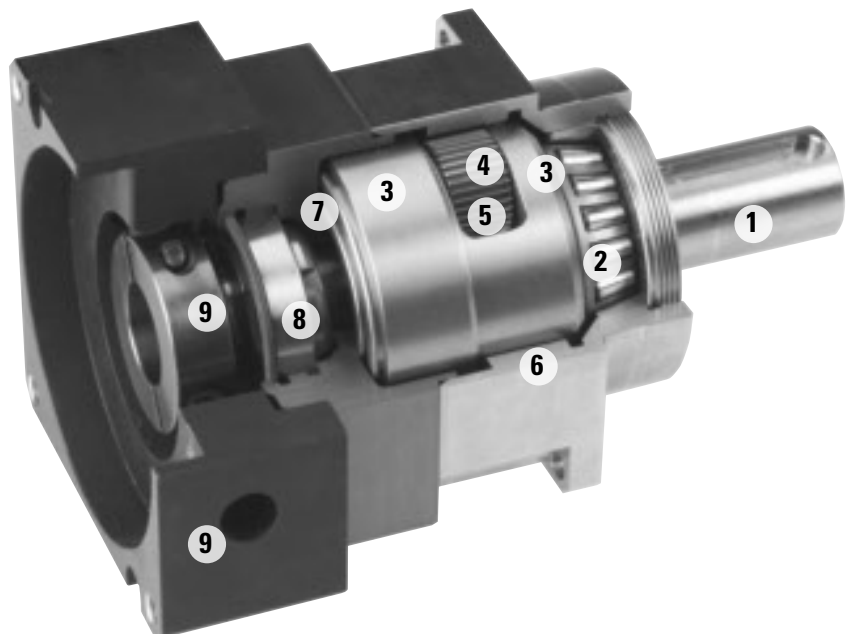

Stainless steel output housing

EverTRUE™ Size 10 Continuous Duty True Planetary™ Gearheads

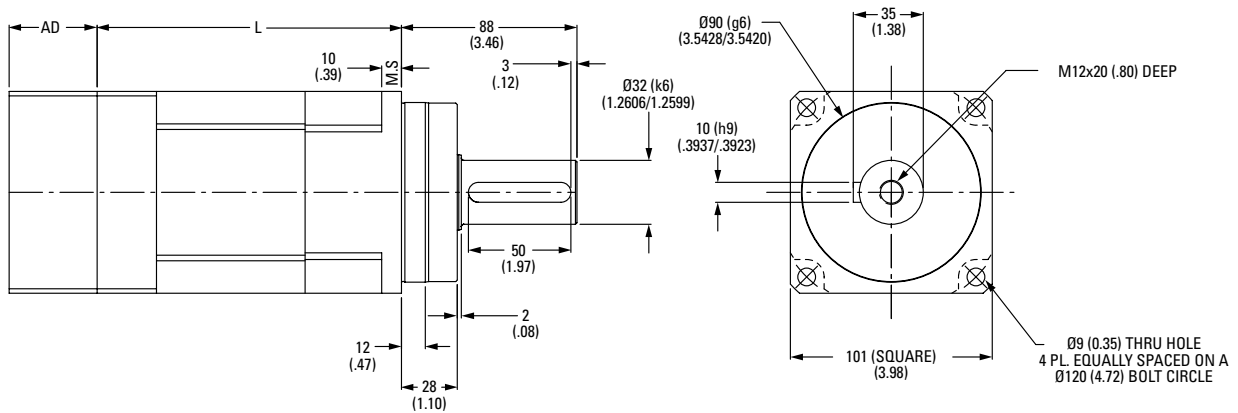

Ratio ¹	Stages	Dimension 'L' mm [in]	Backlash [arc-min]	Weight kg [lb]	Efficiency
4:1 to 10:1	1	78 [3.07]	4 max	6 [13]	95%
16:1 to 100:1	2	146 [5.75]	5 max	8 [18]	90%

All dimensions are in mm (in)
AD** = Adapter length
Adapter length will vary depending on motor.
Efficiency is calculated at 100% of the rated torque.

Performance Specifications

Part Number	Ratio ¹	Intermittent (Trc) Nm [in-lb]	30000 Hour Life			T _{peak} Nm [in-lb]	J kg-cm ² [in-lb-sec ² ×10 ⁻⁴]	Torsional Stiffness Nm/arc-min [in-lb/arc-min]
			T _r (1000 rpm) Nm [in-lb]	T _r (3000 rpm) Nm [in-lb]	T _r (5000 rpm) Nm [in-lb]			
ET010-004	4:1	171 [1514]	147 [1303]	106 [937]	91 [804]	463 [4093]	1,50 [13.3]	28,27 [250]
ET010-005	5:1	178 [1579]	144 [1272]	110 [977]	95 [838]	451 [3991]	1,29 [11.5]	25,08 [222]
ET010-007	7:1	190 [1684]	137 [1217]	118 [1042]	101 [893]	433 [3830]	0,92 [8.1]	23,21 [205]
ET010-010	10:1	106 [940]	77 [677]	66 [581]	61 [539]	411 [3640]	0,86 [7.6]	15,84 [140]
ET010-016	16:1	245 [2166]	164 [1450]	151 [1340]	138 [1218]	517 [4577]	1,05 [9.2]	30,03 [267]
ET010-020	20:1	249 [2205]	166 [1470]	154 [1364]	147 [1303]	524 [4637]	1,05 [9.2]	26,73 [237]
ET010-025	25:1	242 [2140]	161 [1421]	150 [1324]	14 [127]	506 [4477]	1,05 [9.2]	26,73 [237]
ET010-028	28:1	255 [2261]	169 [1499]	158 [1399]	152 [1345]	533 [4718]	0,89 [7.9]	23,21 [205]
ET010-035	35:1	248 [2191]	164 [1448]	153 [1355]	148 [1306]	514 [4549]	0,75 [6.7]	22,99 [204]
ET010-040	40:1	262 [2316]	173 [1528]	162 [1433]	156 [1383]	542 [4794]	0,75 [6.7]	30,14 [267]
ET010-050	50:1	253 [2243]	167 [1475]	157 [1387]	152 [1341]	521 [4615]	0,74 [6.6]	26,51 [235]
ET010-070	70:1	241 [2131]	158 [1396]	149 [1318]	144 [1277]	491 [4349]	0,74 [6.6]	23,21 [205]
ET010-100	100:1	144 [1277]	102 [902]	89 [790]	84 [741]	459 [4059]	0,74 [6.6]	18,92 [168]

¹ Ratios are exact, higher ratios are also available, consult factory.
T_r = Rated output torque at rated speed for specific hours of life.
T_{rc} = Rated output torque for intermittent operation at 3,000 RPM
(20,000 hr life - for catalog comparison)

T_{peak} = Allowable momentary peak torque for emergency stop or heavy shock loading.
J = Mass moment of inertia reflected to the input shaft (including pinion assembly).

EverTRUE™ Size 14 Continuous Duty

True Planetary™ Gearheads

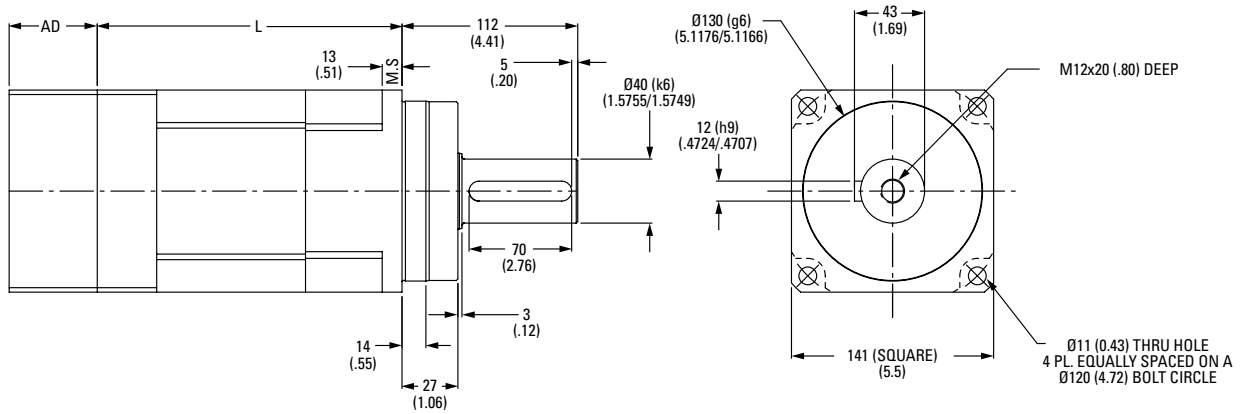

Ratio ¹	Stages	Dimension 'L' mm [in]	Backlash [arc-min]	Weight kg [lb]	Efficiency
4:1 to 10:1	1	110,5 [4.35]	4 max	14 [31]	95%
16:1 to 100:1	2	195 [7.69]	5 max	18 [40]	90%

All dimensions are in mm (in)
 AD** = Adapter length
 Adapter length will vary depending on motor.
 Efficiency is calculated at 100% of the rated torque.

Performance Specifications

Part Number	Ratio ¹	Intermittent (Trc) Nm [in-lb]	30000 Hour Life			T _{peak} Nm [in-lb]	J kg-cm ² [in-lb-sec ² x10 ⁻⁴]	Torsional Stiffness Nm/arc-min [in-lb/arc-min]
			T _r (1000 rpm) Nm [in-lb]	T _r (3000 rpm) Nm [in-lb]	T _r (5000 rpm) Nm [in-lb]			
ET014-004	4:1	417 [3694]	345 [3055]	258 [2285]	221 [1960]	1066 [9431]	6,18 [55]	60,50 [536]
ET014-005	5:1	435 [3849]	336 [2972]	269 [2381]	231 [2042]	1040 [9206]	4,77 [42]	56,10 [497]
ET014-007	7:1	464 [4105]	322 [2849]	287 [2539]	246 [2179]	1002 [8866]	3,61 [32]	51,70 [458]
ET014-010	10:1	253 [2237]	183 [1618]	156 [1384]	145 [1279]	956 [8459]	3,22 [29]	38,50 [341]
ET014-016	16:1	573 [5070]	386 [3413]	354 [3136]	336 [2971]	1206 [10674]	4,00 [35]	63,80 [565]
ET014-020	20:1	584 [5168]	391 [3463]	361 [3197]	345 [3055]	1224 [10832]	3,87 [34]	59,40 [526]
ET014-025	25:1	567 [5016]	378 [3347]	351 [3103]	336 [2972]	1182 [10463]	3,87 [34]	59,40 [526]
ET014-028	28:1	600 [5309]	399 [3535]	371 [3284]	356 [3150]	1248 [11047]	3,35 [30]	51,70 [458]
ET014-035	35:1	581 [5145]	386 [3415]	360 [3182]	346 [3059]	1204 [10653]	2,84 [25]	48,40 [428]
ET014-040	40:1	616 [5448]	408 [3608]	381 [3370]	367 [3245]	1271 [11248]	2,84 [25]	63,80 [565]
ET014-050	50:1	596 [5274]	393 [3482]	369 [3262]	356 [3146]	1224 [10831]	2,71 [24]	59,40 [526]
ET014-070	70:1	567 [5019]	373 [3299]	351 [3104]	339 [3002]	1155 [10223]	2,71 [24]	53,90 [478]
ET014-100	100:1	346 [3058]	245 [2164]	214 [1892]	200 [1772]	1081 [9564]	2,71 [24]	38,50 [341]

¹ Ratios are exact, higher ratios are also available, consult factory.
 T_r = Rated output torque at rated speed for specific hours of life.
 T_{rc} = Rated output torque for intermittent operation at 3,000 RPM
 (20,000 hr life - for catalog comparison)

T_{peak} = Allowable momentary peak torque for emergency stop or heavy shock loading.
 J = Mass moment of inertia reflected to the input shaft (including pinion assembly).

EverTRUE™ Size 18 Continuous Duty

True Planetary™ Gearheads

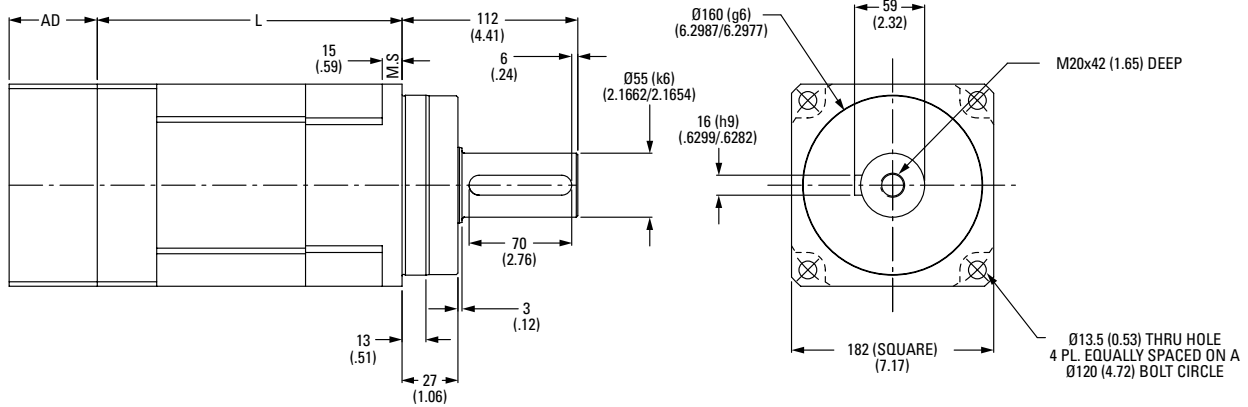

Ratio ¹	Stages	Dimension 'L' mm [in]	Backlash [arc-min]	Weight kg [lb]	Efficiency
4:1 to 10:1	1	136 [5.35]	4 max	40 [88]	95%
16:1 to 100:1	2	244 [9.59]	5 max	45 [99]	90%

All dimensions are in mm (in)
 AD** = Adapter length
 Adapter length will vary depending on motor.
 Efficiency is calculated at 100% of the rated torque.

Performance Specifications

Part Number	Ratio ¹	Intermittent (Trc) Nm [in-lb]	30000 Hour Life			T _{peak} Nm [in-lb]	J kg-cm ² [in-lb-sec ² ×10 ⁻⁴]	Torsional Stiffness Nm/arc-min [in-lb/arc-min]
			T _r (1000 rpm) Nm [in-lb]	T _r (3000 rpm) Nm [in-lb]	T _r (5000 rpm) Nm [in-lb]			
ET018-004	4:1	933 [8254]	802 [7099]	577 [5105]	495 [4380]	2442 [21609]	24,61 [218]	168,30 [1461]
ET018-005	5:1	972 [8602]	782 [6923]	601 [5321]	516 [4565]	2389 [21143]	19,00 [168]	165,00 [1461]
ET018-007	7:1	1037 [9174]	752 [6652]	641 [5675]	550 [4868]	2308 [20429]	13,87 [123]	147,40 [1306]
ET018-010	10:1	592 [5242]	430 [3806]	366 [3242]	338 [2990]	2210 [19561]	12,35 [109]	111,10 [984]
ET018-016	16:1	1335 [11816]	904 [8003]	826 [7309]	750 [6639]	2800 [24779]	15,30 [136]	177,10 [1569]
ET018-020	20:1	1363 [12061]	919 [8129]	843 [7460]	802 [7099]	2846 [25187]	14,82 [131]	171,60 [1520]
ET018-025	25:1	1325 [11722]	889 [7866]	819 [7251]	782 [6923]	2754 [24370]	14,82 [131]	144,10 [1277]
ET018-028	28:1	1403 [12414]	939 [8311]	868 [7679]	830 [7342]	2910 [25751]	12,83 [114]	151,80 [1345]
ET018-035	35:1	1361 [12047]	908 [8033]	842 [7452]	807 [7142]	2810 [24870]	10,83 [96]	136,40 [1209]
ET018-040	40:1	1443 [12767]	960 [8492]	892 [7897]	857 [7580]	2970 [26281]	10,83 [96]	177,10 [1569]
ET018-050	50:1	1398 [12371]	927 [8201]	865 [7652]	832 [7361]	2863 [25338]	10,36 [92]	171,60 [1520]
ET018-070	70:1	1332 [11789]	879 [7778]	824 [7292]	795 [7037]	2707 [23959]	10,36 [92]	151,80 [1345]
ET018-100	100:1	816 [7219]	578 [5117]	505 [4465]	472 [4180]	2537 [22454]	10,36 [92]	113,30 [1004]

¹ Ratios are exact, higher ratios are also available, consult factory.
 T_r = Rated output torque at rated speed for specific hours of life.
 T_{rc} = Rated output torque for intermittent operation at 3,000 RPM
 (20,000 hr life - for catalog comparison)

T_{peak} = Allowable momentary peak torque for emergency stop or heavy shock loading.
 J = Mass moment of inertia reflected to the input shaft (including pinion assembly).

Radial and Axial Load Ratings

ET010

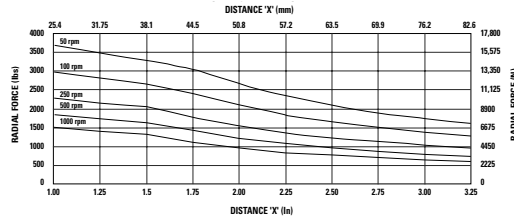
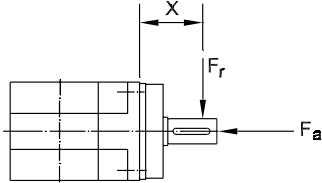

Speed rpm	Axial Load, F_a N [lb _f]
50	13675 [3075]
100	11107 [2497]
250	8435 [1897]
500	6855 [1542]
1000	5568 [1252]

ET014

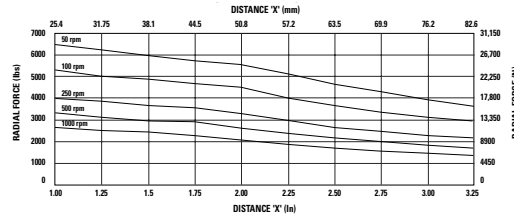
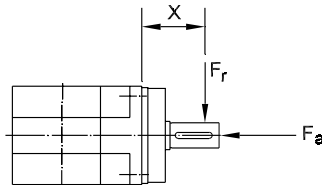

Speed rpm	Axial Load, F_a N [lb _f]
50	25074 [5705]
100	20609 [4633]
250	15657 [3520]
500	12716 [2859]
1000	10329 [2322]

ET018

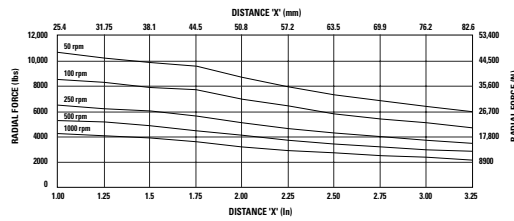
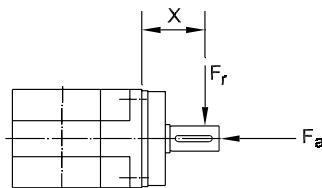

Speed rpm	Axial Load, F_a N [lb _f]
50	34538 [7765]
100	27414 [6163]
250	20197 [4541]
500	16034 [3605]
1000	12726 [2861]

These graphs display the allowable radial load at a given distance (X) from the mounting surface based on an L₁₀ life of 10,000 hours for the mean output speed n_{mout} , as described on page 10.



Gearhead Application Analysis Form

General Information

Customer Name: _____ Fax: _____ Order Date: _____

Buyer Contact: _____ Phone: _____ Required Date: _____

Technical Contact: _____

Bill to Address: _____ Town/County: _____ State/Zip: _____

Ship to Address: _____ Town/County: _____ State/Zip: _____

E-mail: _____ Website: _____

Motor Information

Motor Manufacturer: _____ Motor Model #: _____

Continuous Torque (Nm) _____ Peak Torque (Nm) _____

Maximum Speed (rpm) _____

Application Information

Brief description of your application: _____

Acceleration time (sec) _____ Acceleration torque (Nm) _____ Max speed (rpm) _____

Dwell time (sec) _____ Dwell torque (Nm) _____ Dwell speed (rpm) _____

Deceleration time (sec) _____ Deceleration torque (Nm) _____ Min speed (rpm) _____

Radial Load (N) _____ Axial Load (N) _____ Target inertia match _____

External load inertia (Nm-sec²) _____ Maximum speed of motor (rpm) _____

Ordering Information

Part Number	Quantity	Price	Delivery
_____	_____	_____	_____

Gearhead Ordering Information

Visit www.micronmotioneering.com to get your complete RediMount part number using your motor manufacturer and model number information.

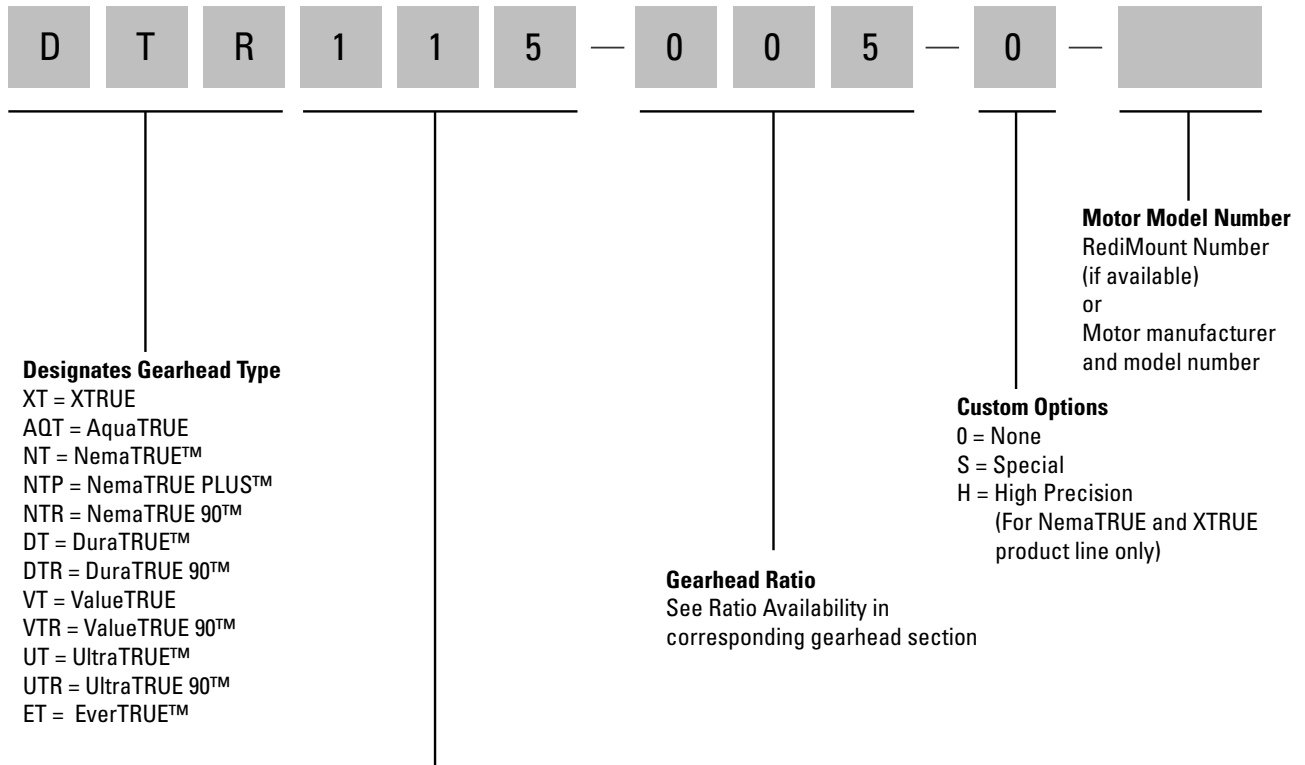

GEARHEAD SIZE

XTRUE™ AquaTRUE™	NemaTRUE™ NemaTRUE PLUS™ NemaTRUE 90™	DuraTRUE™ DuraTRUE 90™ DuraTRUE™ (Hollow Shaft) DuraTRUE™ (Dual Shaft)	UltraTRUE™ UltraTRUE 90™	EverTRUE™	ValueTRUE™ ValueTRUE 90™
40 = 40mm	17 = Size 17	60 = Size 60	006 = Size 60	10 = Size 10	006 = Size 60
60 = 60mm	23 = Size 23	90 = Size 90	075 = Size 75	14 = Size 14	075 = Size 75
80 = 80mm	34 = Size 34	115 = Size 115	090 = Size 90	18 = Size 18	090 = Size 90
120 = 120mm	42 = Size 42	142 = Size 142	010 = Size 10		010 = Size 10
160 = 160mm	60 = Size 60		115 = Size 115		115 = Size 115
	90 = Size 90		014 = Size 14		014 = Size 14
	115 = Size 115		018 = Size 18		018 = Size 18
			022 = Size 22 (UltraTRUE™ only)		022 = Size 22





***Micron True Planetary™ Gearheads
shipped within 24 hours!***

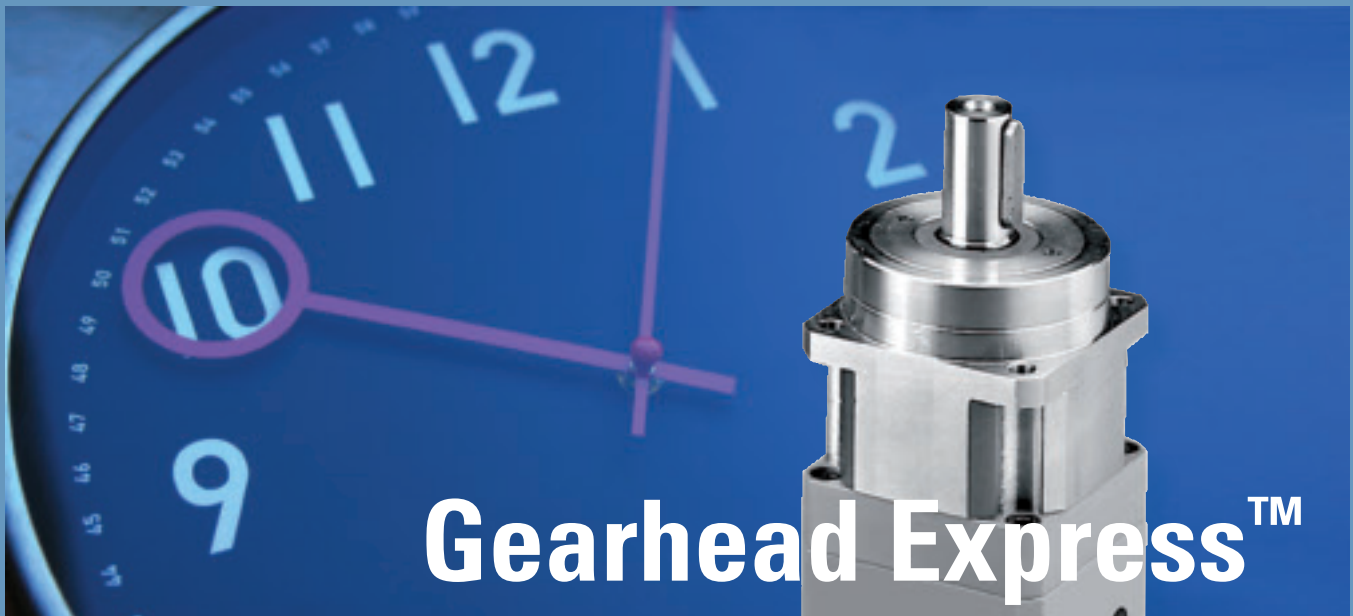

Need it fast?

***Take advantage of the Gearhead Express Program
for quick delivery.***

All standard in-line frame sizes and ratios for the NemaTRUE, DuraTRUE, UltraTRUE and ValueTRUE products are available to ship in 24 hours through the Gearhead Express Program. That is over 350 gearheads to choose from. The parts included in the program are listed below. Please contact customer service for directions on how to order. For details on how to use the Gearhead Express program, please visit www.micronmotioneering.com.

- **NemaTRUE**
Frame sizes 23, 34, 42, 60, 90 and 115
Ratios: 3, 4, 5, 7, 10, 15, 20, 30, 40, 50, 70 and 100:1
- **DuraTRUE**
Frame sizes 60, 90, 115 and 142
Ratios: 3, 4, 5, 7, 10, 15, 20, 25, 30, 40, 50, 70 and 100:1
- **UltraTRUE**
Frame sizes 6, 7.5, 10 and 14
Ratios: 4, 5, 7, 10, 16, 20, 25, 28, 35, 40, 50, 70 and 100:1
- **ValueTRUE**
Frame sizes 6, 7.5, 10 and 14
Ratios: 4, 5, 7, 10, 16, 20, 25, 28, 35, 40, 50, 70 and 100:1

***Visit: www.thomsonlinear.com
or call: 1-540-633-3549***

THOMSON
Linear Motion. Optimized.™

USA, CANADA and MEXICO

Thomson
203A West Rock Road
Radford, VA 24141 USA
Phone: 1-540-633-3549
Fax: 1-540-633-0294
E-mail: thomson@thomsonlinear.com
Literature: literature.thomsonlinear.com

EUROPE

United Kingdom

Thomson
Fishleigh Road
Barnstaple
EX31 3UD
United Kingdom
Phone: +44 (0)1271 334 500
Fax: +44 (0)1271 334 501
E-mail: sales.uk@thomsonlinear.com

Germany

Thomson
Nürtinger Straße 70
72649 Wolfschlügen
Phone: +49 (0) 7022 504 100
Fax: +49 (0) 7022 504 405
E-Mail: sales.wolfschlügen@thomsonlinear.com

Italy

Thomson
Largo Brughetti
I-20030 Bovisio Masciago
Italy
Phone: +39 0362 594260
Fax: +39 0362 594263
E-mail: info@thomsonlinear.it

Sweden

Thomson
Box 9053
SE-291 09 Kristianstad
Sweden
Phone: +46 (0) 44-24 67 00
Fax: +46 (0) 44-24 40 85
E-mail: sales.scandinavia@thomsonlinear.com

France

Thomson
C.P 80018
12, Rue Antoine Becquerel – Z.I. Sud
F-72026 Le Mans Cedex 2
France
Phone: +33 (0) 243 50 03 30
Fax: +33 (0) 243 50 03 39
E-mail: sales.france@thomsonlinear.com

Spain

Thomson
Rbla Badal, 29-31 7th, 1st
08014 Barcelona
Spain
Phone: +34 (0) 9329 80278
Fax: +34 (0) 9329 80278
Email: josep.estaran@thomsonlinear.com

ASIA

China

Thomson
Rm 2206, Scitech Tower No22
Jianguomenwai Avenue
Beijing, China, 100004
Phone: +86 400 666 1802
Fax: +86 10 6515 0263
E-mail: sales.china@thomsonlinear.com

Japan

Thomson
2F, Sigma Hatchobori Bldg,
2-7-1 Hatchobori Chuo-ku,
Tokyo 104-0032 Japan
Phone: +81-3-6222-1051
Fax: +81-3-6222-1055
E-mail: info@danahermotion.co.jp

Asia Pacific

Thomson
Unit A, 16 Floor, 169 Electric Road
Manulife Tower, North Point
Hong Kong
Phone: +852 2503 6581
Fax: +852 2571 8585
E-mail: richard.teo@danaher.com

Korea

Thomson
#407, Kins Tower
Bundang Inteligy1, 25-1, Jeongja-dong,
Bundang-gu, Seongnam-city
Kyunggi-do, Korea
Phone: +82 31 931 5170
Fax: +82 31 931 5176
E-mail: aaron.kim@danahermotion.com

India

Thomson
Unit No 2, SDF 1
Seepz
Andheri, Mumbai 400 096, India
Phone: +91 22 28294058
Fax: +91 22 28394036
E-mail: girish.mahajani@danahermotion.com

200712-02 TPS 3K 10/2010 USA
Specifications are subject to change without notice. It is the responsibility of the product user to determine the suitability of this product for a specific application. All trademarks property of their respective owners.
© 2010 Thomson Industries, Inc.